

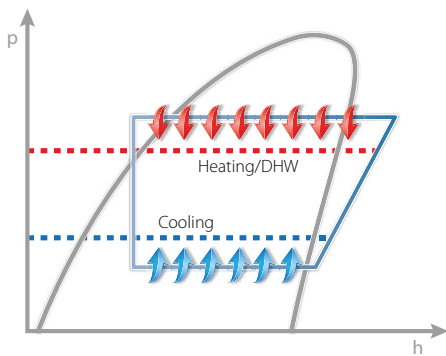

TOTAL HEAT RECOVERY MULTI-PURPOSE HEAT PUMPS



Energy saving thanks to a total recovery

Galletti multi-purpose heat pumps are total recovery units used for a simultaneous hot and cold water production. Available for a 2-pipe system, DHW production under request, or a 4-pipe system, designed for service and residential sectors.

As well as winter heating and summer air conditioning, in case of a 2-pipe air-conditioning systems in which, thermal power for the DHW production is required, Galletti multi-purpose systems are equipped with a plate heat exchanger used for the DHW production.

Thanks to the advanced technology of these systems, they can satisfy this request in every season, also when there is no need of air-conditioning, but that's not all! They can do that efficiently by using the total recovery of condensation heat available during cooling phase.

Production of chilled water with total condensation heat recovery for DHW production

- LEGEND:**
S1: "user side" plate exchanger
S2: "DHW production side" plate exchanger
S3: Finned block heat exchanger

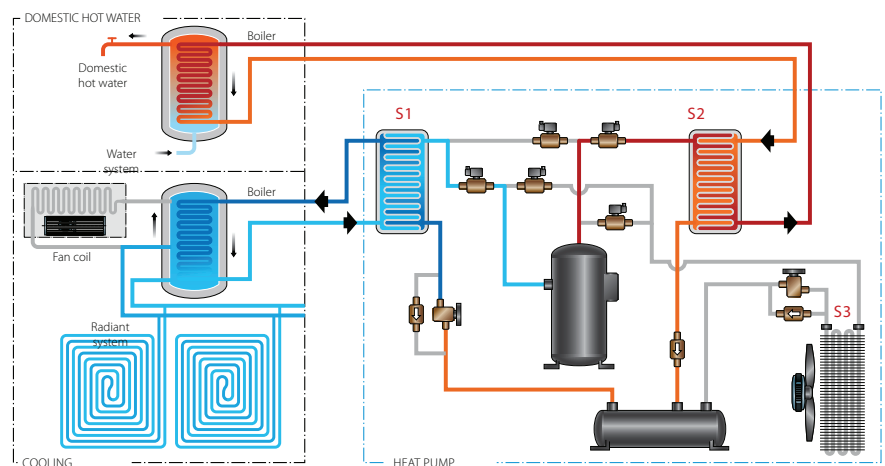

Partial load efficiency



It is necessary to guarantee that the generation system provides high values of COP/EER even in partial load efficiency which, often, corresponds to the greatest number of working hours in a seasonal cycle.

According to Galletti multi-purpose series, this purpose is achieved through a meticulous thermodynamic design of all main components.

As for the multi-purpose heat pumps which have one cooling circuit, it is possible to modulate the thermal power released through the variation of frequency in the single compressor activated by a BLDC motor.

When on-off compressors are used, high efficiency is guaranteed also for partial loads through different steps of operation due to compressors, divided in one or two thermodynamic circuits.

Additional total recovery heat pumps compared to traditional generation systems.

- ✓ High renewable energy availability can be obtained from the environment using different methods.
- ✓ Respect for the environment through energy efficiency due to the excellent COP and EER values
- ✓ Reduction in the consumption of fossil energy (ideal for photovoltaic systems combinations)
- ✓ Risks of explosion, fire and indoor burning materials poisoning prevented
- ✓ Totally programmable with the possibility of remote management and on line assistance
- ✓ Low maintenance due to the absence of wearing parts
- ✓ Low-Noise execution
- ✓ No CO₂ and local harmful emissions
- ✓ It does not pollute and it can be fueled by renewable energy sources
- ✓ Maximum savings on running costs combined with high environmental sustainability
- ✓ One unit substituting boilers and air-conditioning units



Air/water split-system with BLDC inverter compressor

HIWARM 12 - 33 kW



Multi-pur-
pose unit
- 2-pipe
system



Total heat
recovery
multi-purpo-
se unit



BLDC
scroll
compressor



R-410A
refrigerant



Cooling /
Heating



Axial fans



Split
execution

The perfect combination between multi-purpose, inverter technology and style

The multi-purpose system HIWARM is the most evolved and efficient solution for conditioning and for the production of DHW in residential or commercial applications: thanks to the total recovery of condensation heat, it is possible to obtain thermal power in a totally free way during summer conditioning.

HIWARM is composed of an outdoor and indoor unit created to be installed in a technical room.

Inside the indoor unit, the compressor, heat exchangers of the systems, hydronic kits, management switchboard and all the main components of the cooling circuit are housed; instead, in the external unit, extremely versatile, there are finned exchanger and electric fans.

This solution has the remarkable advantage to keep all hydraulic circuits inside the building thus avoiding the need to protect the system from the risk of freezing through the use of heating elements or by adding glycol-based materials. Both these solutions inevitably lead to an increase of the consumption of electrical energy.

Moreover, the external unit thus created has a double advantage: it can be easily installed both vertically and horizontally and, since it is particularly lightweight, doesn't need expensive supporting structures.

HIWARM includes the state of the art as regards cooling and hydraulic components: from the compressor activated by a BLDC motor to maximize energetic efficiency in every operating mode, to the axial fans with airfoil blades and external rotor motor, from the high-efficiency plate heat exchangers to the electronically-controlled electrical expansion valve managed by a PID regulation algorithm. The thermal exchange has been optimized in every operating mode through the use of a 4-way reverse cycle valve on the water side to always keep opposite the flow of refrigerant and thermal fluids, thus extending the operating range of the unit.

PLUS

- ✓ Total heat recovery for DHW production
- ✓ Twin-rotary compressor or scroll activated by an electronically controlled BLDC motor
- ✓ Electronically controlled electric expansion valve
- ✓ Double cycle reversal: refrigerant and water side
- ✓ BLDC circulators with stainless steel impeller for system and DHW
- ✓ Access to the tax incentives provided for energy retrofitting

The modulation of capacity facilitates the variation of the thermal load of the building. During the operation and production of DHW, HIWARM transfers all its available power to compensate, in the most efficient way, the withdrawal of domestic hot water.

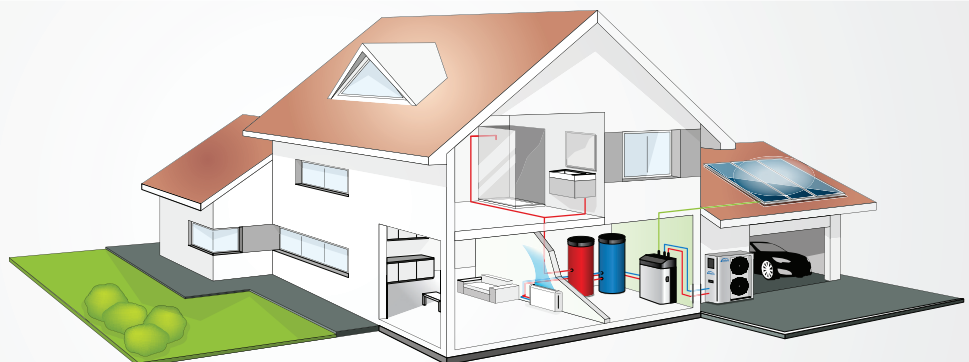



MAIN COMPONENTS

Outdoor unit

Finned coil made of copper pipes mechanically fixed to steel fins, accurately designed to minimize defrosting phase and optimize the efficiency of thermal exchange in every operating mode. It is available with horizontal and vertical air flow.



Indoor unit

Made of painted sheet Enclosing panels made of painted galvanized sheet with polymerized epoxy-polyester powders and available in four different colours for a pleasant aesthetic.

Electronically controlled electric expansion valve

Together with the compressor, it is the key element for the operation of the unit. Thanks to the PID algorithm that regulates it, it is capable of quickly adjusting to every working condition and maintain the cooling cycle steady.

Compressor

Twin-rotary or scroll hermetic compressor activated by BLDC permanent magnet motor and included in a completely sound-proof panelling, isolated from the main structure through anti-vibrating rubber dampers.

Microprocessor control

The cutting-edge microprocessor control includes a high-technology software developed by Galletti which allows the complete and efficient management of IWARM units.



Hydraulic kit

Centrifugal circulators activated by BLDC electrical motors with stainless steel impeller and managed by the control panel of the unit to adjust the flow rate of water according to operating conditions and keep the compressor within its operating range.

CONFIGURATION

The models are completely configurable by selecting the version and the options. To the right is shown an example of configuration.

Version	Optional ▶	1	2	3	4	5	6	7	8	9
HWM012M0		4	7	7	0	C	0	0	A	0

To verify the compatibility of the options, use the selection software or the price list.

AVAILABLE VERSIONS

Total heat recovery multi-purpose unit

- HWM...MO** Indoor unit for 2-pipe system + external remote unit with horizontal air flow
- HWM...MV** Indoor unit for 2-pipe system + external remote unit with vertical air flow
- HWM...MI** Indoor unit for 2-pipe system + indoor remote unit with ducted air flow (EC fans standard)

CONFIGURATION OPTIONS

1 - POWER SUPPLY

- 4** 230/1/50 + Inverter + Thermal magnetic circuit breakers (size 012 only)
- 5** 400/3/50 + Inverter + Thermal magnetic circuit breakers

2 - WATER PUMP ON USER SIDE

- 7** Modulating BLDC single pump

3 - WATER PUMP ON RECOVERY SIDE

- 7** Modulating BLDC single pump

4 - REMOTE COMMUNICATION

- 0** Absent
- 1** RS485 Serial board (Modbus or Carel protocol)
- 2** Lonworks serial board
- 3** GSM modem kit
- 4** Ethernet pCOWEB board (SNMP or BACNET protocol)
- 6** pCOWEB Ethernet card + "GWEB" supervision software

5 - AIR-FLOW MODULATION IN THE REMOTE UNIT

- C** Condensation control with fans adjusted by potentiometer
- E** Condensation control, "EC brushless" electronically controlled fans (V_0 versions only)

6 - REMOTE CONTROL

- 0** Absent
- 3** Remote display for pCO

7 - PACKING

- 0** Standard
- 1** Wooden crate
- 2** Wooden case

8 - EXTERIOR COLOUR

- B** White - RAL 9016 polish
- A** Silver grey - RAL 9006 metallised
- G** Dark grey - RAL 7016 metallised
- P** Blue - RAL 7031 polish
- R** Bordeaux - RAL 3003 polish

9 - SPECIAL HEAT EXCHANGERS

- 0** Standard heat exchangers with hydrophilic treatment
- R** Copper / copper
- C** Cataphoresis
- B** Fins pre-coated with epoxy paint

ACCESSORIES

- A** Heat exchanger protection net for outdoor unit
- B** Four water pipe GAS threaded fittings
- C** Normative reference other than "97/23/CE - PED"
- D** Inversion kit for system tank

Total heat recovery multi-purpose heat pumps HIWARM

Rated technical data

HIWARM		HIWARM 012		HIWARM 022		HIWARM 033	
Power supply	V-ph-Hz	230 - 1 - 50		400 - 3N - 50		400 - 3N - 50	
Compressor status		min	max	min	max	min	max
Cooling mode (1)							
Cooling Capacity	kW	3,04	11,2	9,20	23,2	9,57	32,0
Total power input	kW	0,78	3,31	2,41	7,60	2,39	11,3
EER		3,91	3,39	3,82	3,05	4,01	2,82
ESEER		5,65	5,65	5,30	5,30	5,24	5,24
User Water Flow Rate	l/h	522	1938	1583	3998	1646	5525
User Water Pressure Drops	kPa	<5	19	<5	21	<5	17
User side water pump available pressure head	kPa	67	43	116	98	118	94
Cooling mode +DHW (2)							
Heating Capacity	kW	2,76	10,6	8,65	22,7	8,95	31,8
Total power input	kW	0,75	3,55	2,47	7,78	2,37	11,4
Heating capacity DHW	kW	3,41	13,7	10,8	29,6	11,0	41,9
COP		8,25	6,85	7,90	6,73	8,43	6,45
User Water Flow Rate	l/h	474	1830	1489	3919	1540	5479
User Water Pressure Drops	kPa	<5	17	<5	20	<5	17
User side water pump available pressure head	kPa	67	46	116	99	118	95
DHW Water Flow Rate	l/h	592	2371	1877	5109	1917	7236
DHW Water Pressure Drops	kPa	<5	27	5	32	<5	28
DHW side water pump available pressure head	kPa	66	28	114	81	116	69
Heating mode or DHW (3)							
Heating Capacity	kW	2,98	12,0	9,56	25,7	9,77	36,0
Total power input	kW	0,89	3,57	2,66	7,76	2,68	11,4
COP		3,33	3,36	3,59	3,31	3,65	3,15
User Water Flow Rate	l/h	517	2071	1658	4441	1696	6225
User Water Pressure Drops	kPa	<5	22	<5	25	<5	21
User side water pump available pressure head	kPa	66	38	115	91	117	85
General Data							
Maximum absorbed current	A	22		22		33	
n° of scroll compressor/ circuits	-			1/1			
Sound power level (4)	dB(A)	54		55		57	
Weight without accessories	kg	199		268		277	
Weight with pump and tank	kg	190		260		270	

(1) Water temperature 12/7 °C, outdoor air temperature 35 °C (UNI EN 14511:2011)

(2) Chilled water temperature 12/7 °C, recovery water temperature 40/45 °C

(3) Water temperature 40/45 °C, outdoor air temperature 7 °C D.B. - 6 °C W.B. (UNI EN 14511:2011)

(4) Sound power level measured according to UNI EN ISO 9614



Dimensional drawings

HIWARM 012 INDOOR UNIT

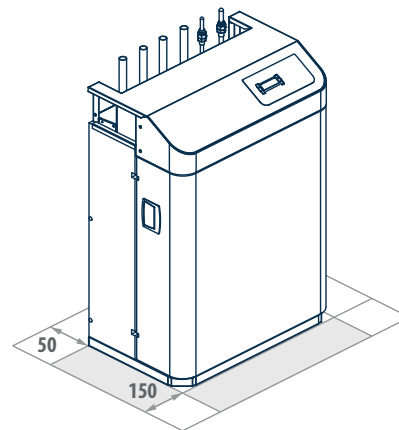
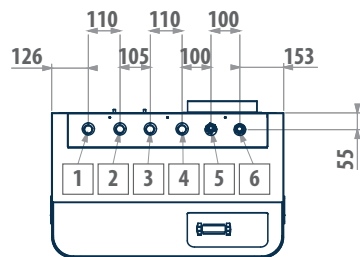
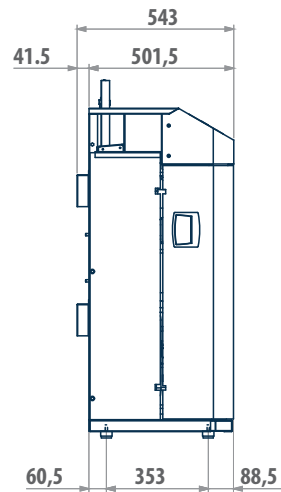
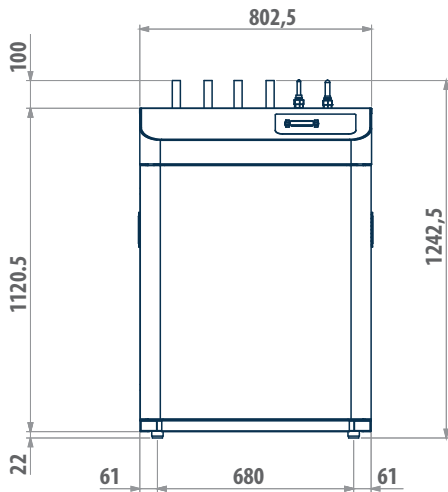

LEGEND

1	Water outlet - air conditioning system	Copper pipe	Ø28
2	Water inlet - air conditioning system	Copper pipe	Ø28
3	Water outlet - DHW system	Copper pipe	Ø28
4	Water inlet - DHW system	Copper pipe	Ø28
5	Liquid line	Rotalock	Ø12
6	Gas line	Rotalock	Ø16

Dimensional drawings

HIWARM 012 EXTERNAL UNIT WITH HORIZONTAL AIR FLOW

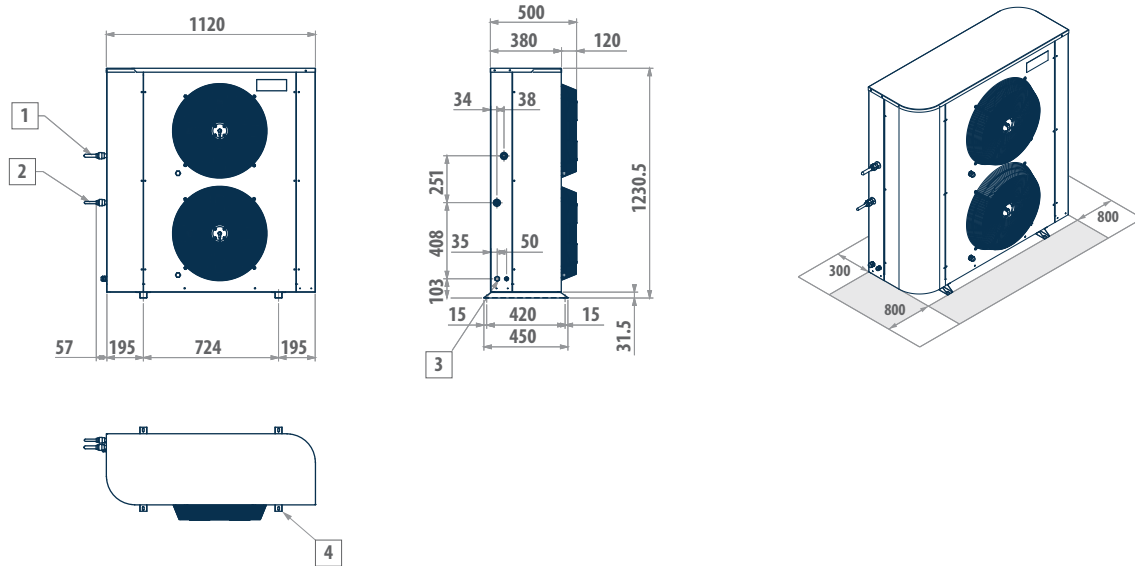

HIWARM 012 EXTERNAL UNIT WITH VERTICAL AIR FLOW

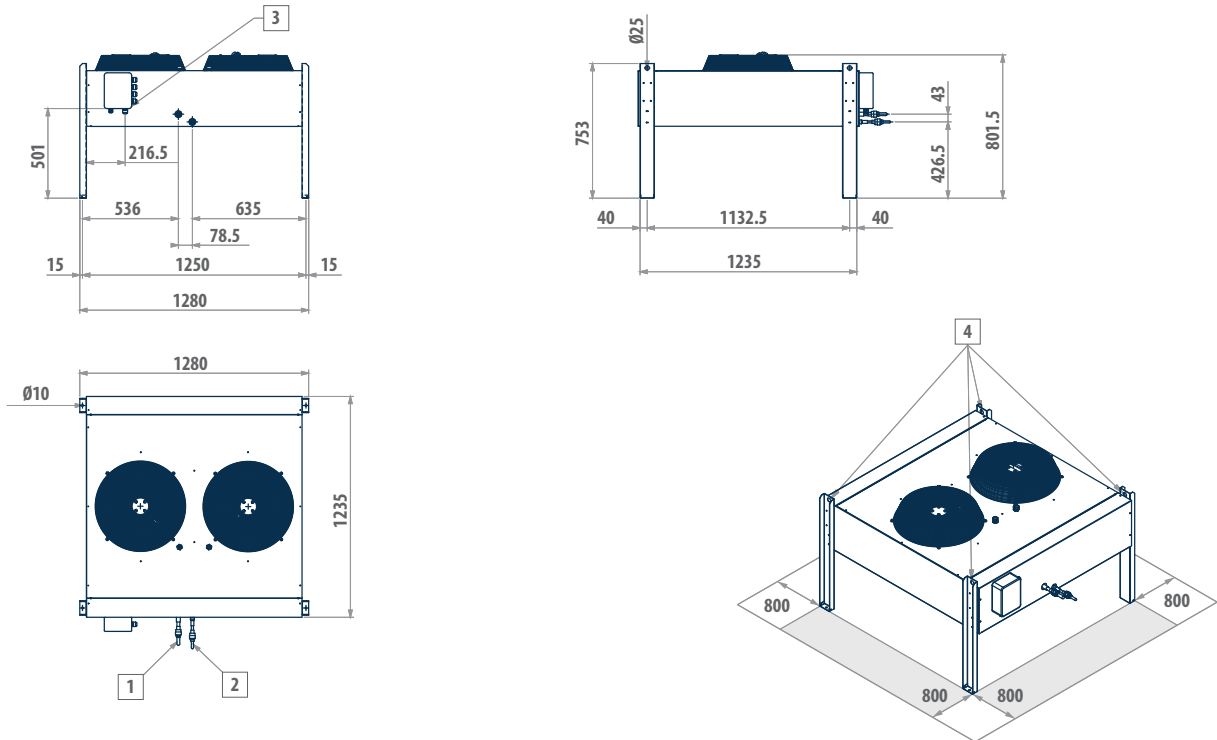

LEGEND

1	Gas line	Rotalock	Ø16
2	Liquid line	Rotalock	Ø12
3	Power supply		
4	Fastening holes		

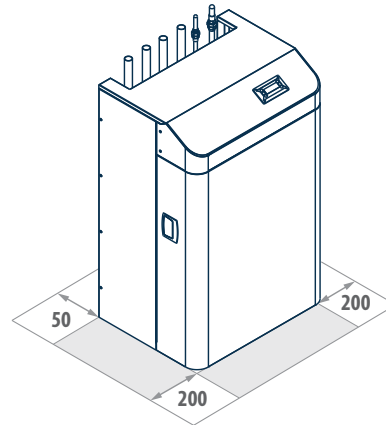
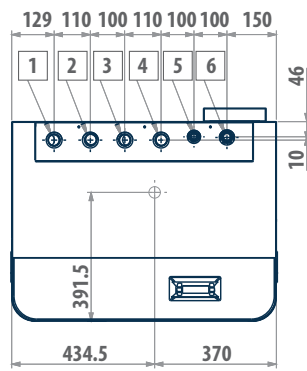
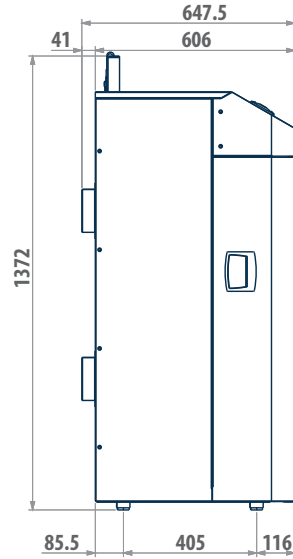
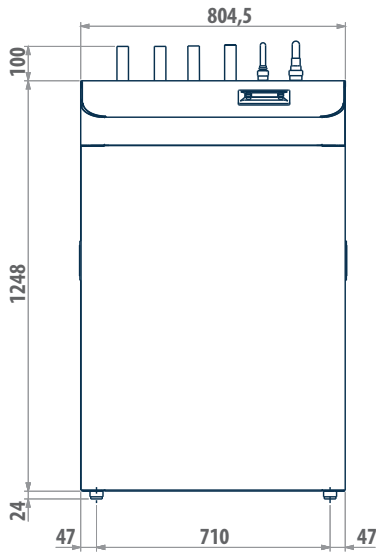
Dimensional drawings
HIWARM 022 - 033 INDOOR UNIT

LEGEND
Plumbing connections

1	Water outlet - air conditioning system	Copper pipe	Ø35
2	Water inlet - air conditioning system	Copper pipe	Ø35
3	Water outlet - DHW system	Copper pipe	Ø35
4	Water inlet - DHW system	Copper pipe	Ø35
5	Liquid line	Rotalock	Ø12
6	Gas line	Rotalock	Ø22

Dimensional drawings

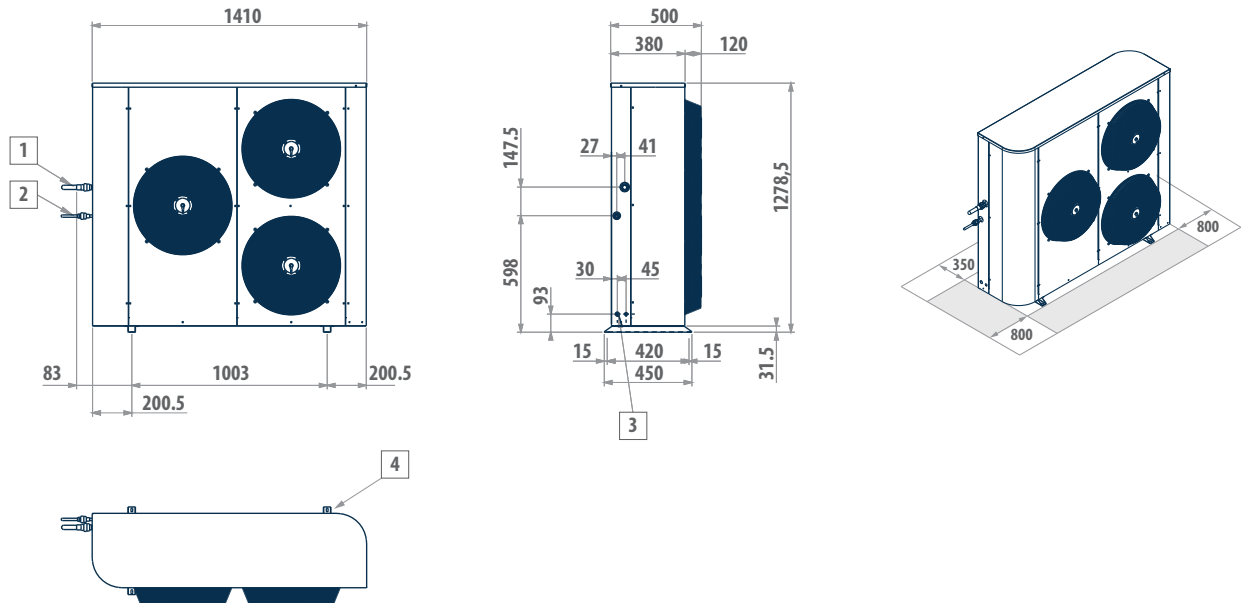
HIWARM 022 EXTERNAL UNIT WITH HORIZONTAL AIR FLOW



HIWARM 022 EXTERNAL UNIT WITH VERTICAL AIR FLOW

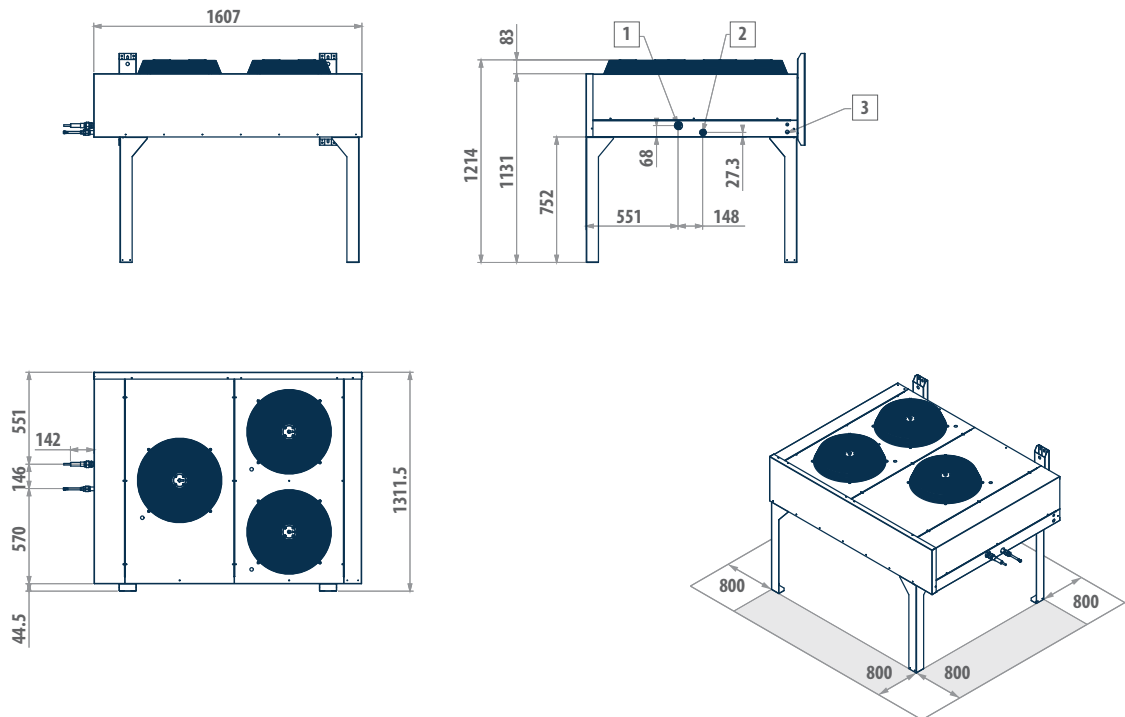

LEGEND

1	Gas line	Rotalock	Ø22
2	Liquid line	Rotalock	Ø16
3	Electrical connection		



Dimensional drawings

HIWARM 033 EXTERNAL UNIT WITH HORIZONTAL AIR FLOW

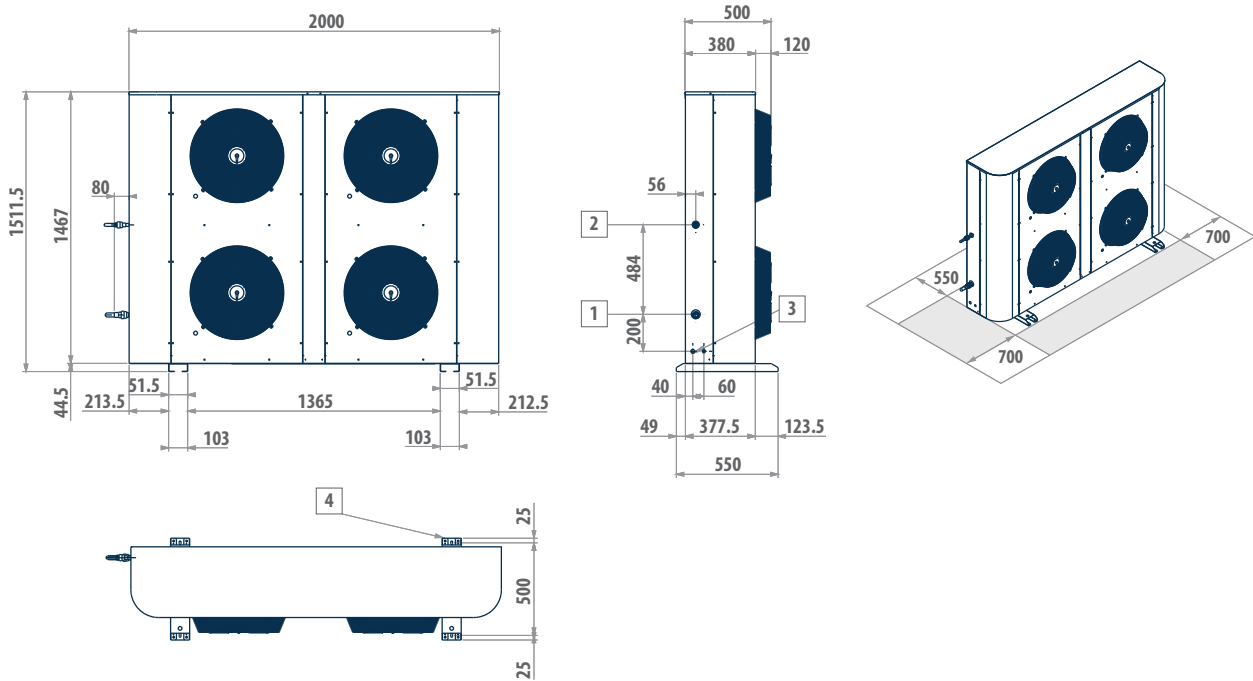

HIWARM 033 EXTERNAL UNIT WITH VERTICAL AIR FLOW

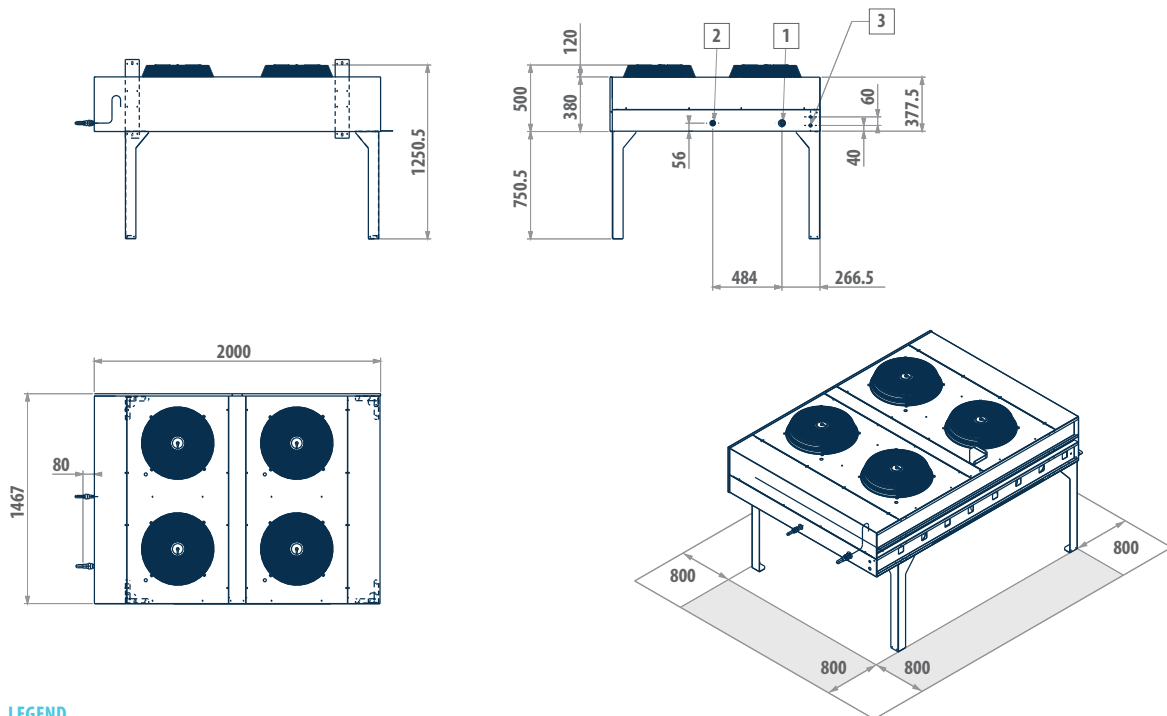

LEGEND

1	Gas line for	Rotalock	Ø22
2	Liquid line	Rotalock	Ø16
3	Electrical connection		