

Refrigerant  
**R410A**  
INVERTER

# AIRSTAGE™ J-II

Variable Refrigerant Flow System

Meeting Various Needs with  
the FUJITSU GENERAL VRF AIRSTAGE Series



**FUJITSU GENERAL LIMITED**  
1116, Suenaga, Takatsu-ku, Kawasaki 213-8502, Japan  
<http://www.fujitsu-general.com/>

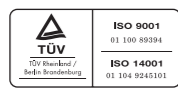

ISO 9001 Certified number : 01 100 89394  
Fujitsu General (Thailand) Co., Ltd.

ISO 14001 Certified number : 01 104 9245101  
Fujitsu General (Thailand) Co., Ltd.



ISO 9001 Certified number : 01 100 79269  
Fujitsu General (Shanghai) Co., Ltd.



ISO 14001 Certified number : 310102-UK  
Fujitsu General (Shanghai) Co., Ltd.



ISO 9001 Certified number : 00608011061R2M  
Fujitsu General Central Air-conditioner (Wuxi) Co., Ltd.

"AIRSTAGE" is a worldwide trademark of FUJITSU GENERAL LIMITED and is a registered trademark in Japan and other countries or areas.

\*Echelon®, LONWORKS®, and the Echelon logo are trademarks of Echelon Corporation registered in the United States and other countries.

\*BACnet® is a registered trademark of the American Society of Heating Refrigeration and Air Conditioning Engineers (ASHRAE).

The colors may be different from the actual colors because this catalog is printed matter.

Product specifications are subject to change without notice.

Distributed by :

**AIRSTAGE™ J-II** from

# Small Office to Large Homes Applications

The AIRSTAGE J-II Series adopts the best technology and was designed with the greatest care to provide not only energy savings and comfort but also ease of design, installation, and maintenance. Fujitsu General provides air conditioning systems for a wide range of applications from small office buildings and stores to large houses.

High Energy Saving

More Design Flexibility

More Comfort

Easy Installation

More Convenience

Easy Maintenance



### OUTDOOR UNITS

Various Line-up for each buildings

- 4HP AJ\*A40LALH
- 5HP AJ\*A45LALH
- 6HP AJ\*A54LALH

AJ\* : AJY (FUJITSU), AJH (GENERAL)



Small Office

Large Homes



Providing the Maximum Satisfaction to **All Customers**

Building owners



Installers



End users



Service and Management companies



Wide lineup of indoor units and controllers to support a variety of properties.

### INDOOR UNITS



Compact Cassette

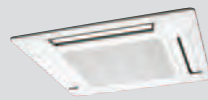

Cassette

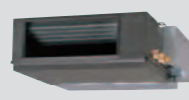

Low Static Pressure Duct



Slim Duct (Drain Pump internal)



Medium Static Pressure Duct



High Static Pressure Duct

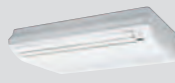

Floor / Ceiling

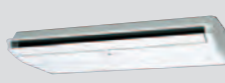

Ceiling



Wall Mounted (EEV internal / EEV external)



Wall Mounted

### CONTROLLERS

#### Central Controller



Central Remote Controller



Group Remote Controller



Touch Panel Controller



System Controller (Software)

#### Individual Controller



Wireless Remote Controller



Simple Remote Controller



Wired Remote Controller



Wired Remote Controller (Touch Panel)

# High Energy Saving

## Efficiency in actual operation

The building load is the range of almost 40% to 80%. Therefore, most air conditioners do not operate at maximum load, but operate at low to medium loads. Especially, for multi system, operation performance at partial load is important because all the air conditioners do not always operate all the time. Aiming at energy saving performance matched to actual operation, Fujitsu General has developed a high intermediate performance air conditioner corresponding not only to the rated performance at 100% load, but also to low to medium load

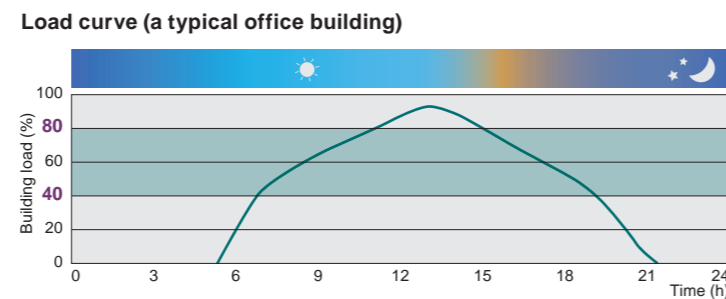

### High EER / COP



### High part load performance (6HP class)

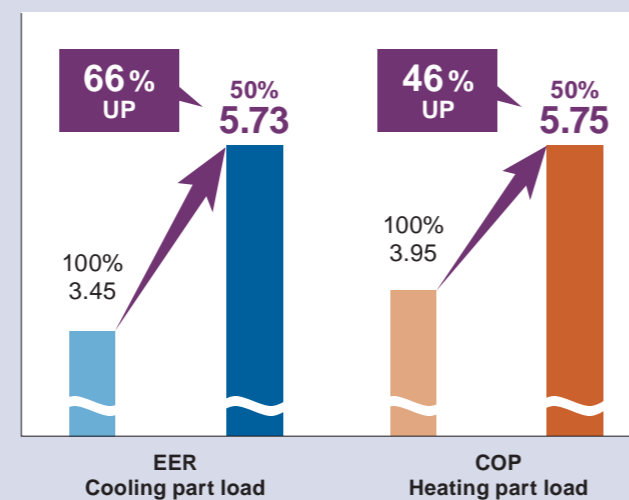

Conditions : Connected indoor units: AUXA30GALH+AUXD24GALH  
 Cooling : indoor temp. of 27°CDB / 19°CWB, outdoor temp. of 35°CDB / 24°CWB  
 Heating : indoor temp. of 20°CDB / 15°CWB, outdoor temp. of 7°CDB / 6°CWB

## Advanced high efficiency technology



### Large propeller fan

High performance and low noise realized by large propeller and optimization of angle.



### DC fan motor

Miniaturized, low noise, high efficiency, multi-stage DC fan motor is mounted.

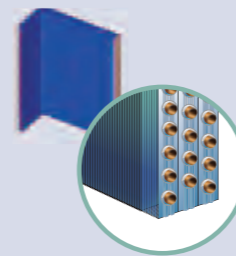

### Large heat exchanger

Heat exchange performance is substantially improved by mounting of 3-row large heat exchanger.



### DC inverter control

Efficiency is improved by mounting of new active filter module.



### Subcool heat exchanger

Cooling performance is improved by mounting of dual tube heat exchanger.

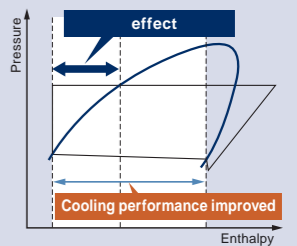

### High efficiency compressor motor

### Optimized refrigerant flow design

### Highly accurate parts

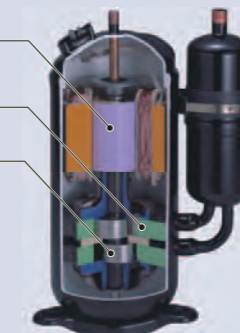

### DC twin rotary compressor

Efficiency in all load regions is good. Especially good performance from low to medium at normal operation.

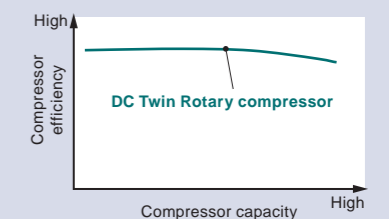

# High Energy Saving Various Energy Saving Function

## Operation Performance is Efficiently Controlled.

### Room temperature set point limitation

The minimum and maximum temperature range can be set.

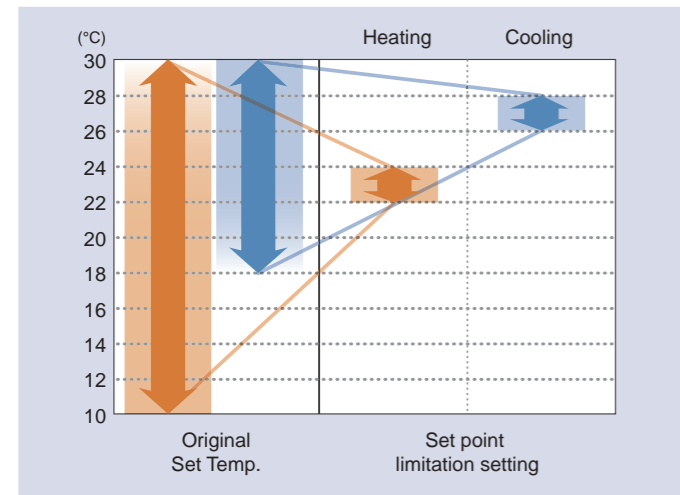

Central Remote Controller

### Economy operation

The temperature setting is offset automatically over a certain period of time.

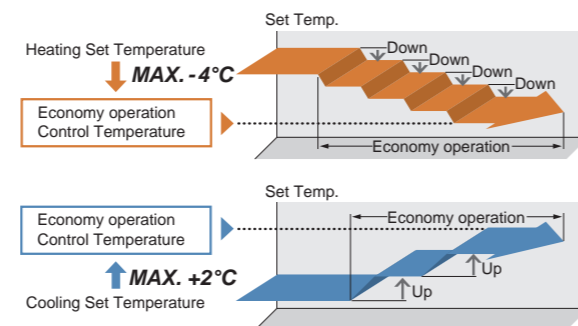

### Capacity save operation

The power consumption at peak can be limited.

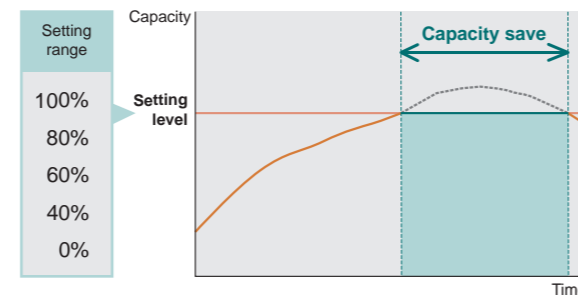

## Wasteful Operation is Prevented.

### Auto Off function

Able to prevent wastage of energy.

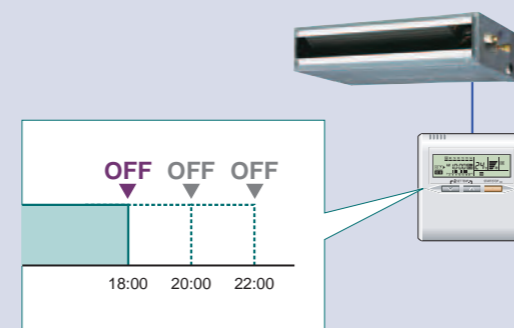

# More Comfort

## Powerful Heating

Heating capacity is improved at low outdoor temperature by our advanced technology.

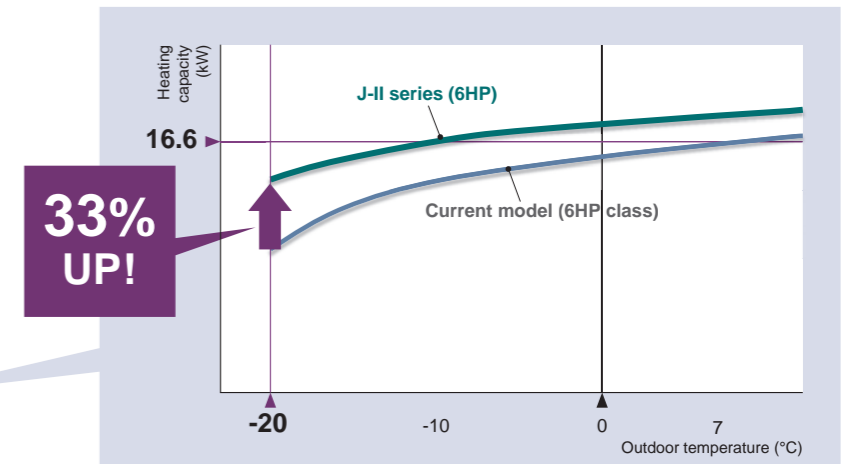

## Low Noise Design

### Low noise design of outdoor unit

Significantly reduced noise by optimized airflow structure design of outdoor unit.

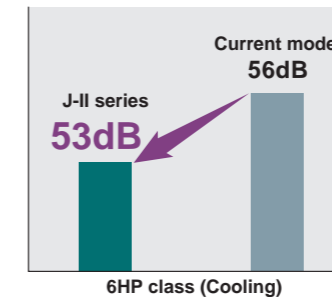

### Low noise mode

Outdoor unit can be switched to silent mode, depending on the installation environment.

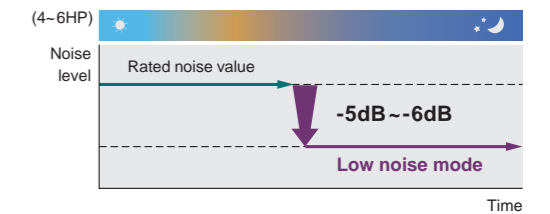

## Various Comfort Control Function

### Easy auto changeover function

At the auto mode, cooling and heating mode is switched automatically to maintain the setting temperature.

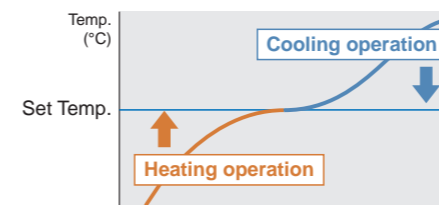

Function setting is required.  
1 indoor unit (Master) can apply this function.

### Non-stop oil recovery operation

The product continues to operate without stopping the cooling or heating operation during oil recovery modes.

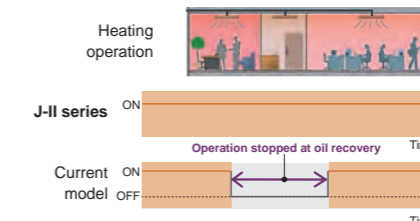

### Auto louver grill (Option for Slim Duct)

Auto louver grill provides comfort and efficient heating with louver controlled ductable outlet

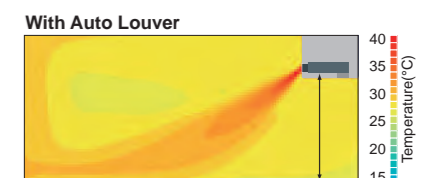

# More Convenience

## Central Control of Small Office, Shop, etc.

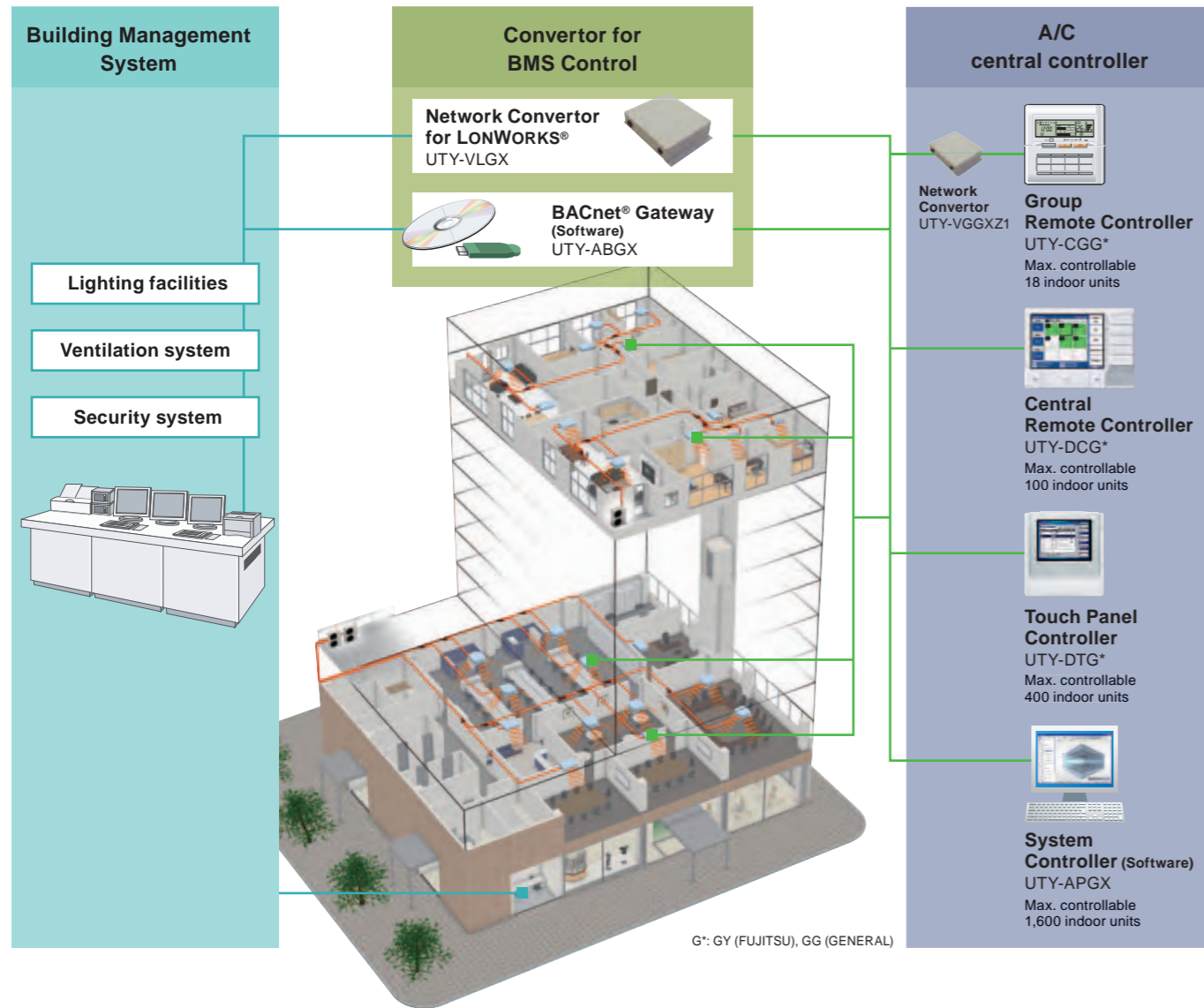

## Individual and Central Control of Large Homes

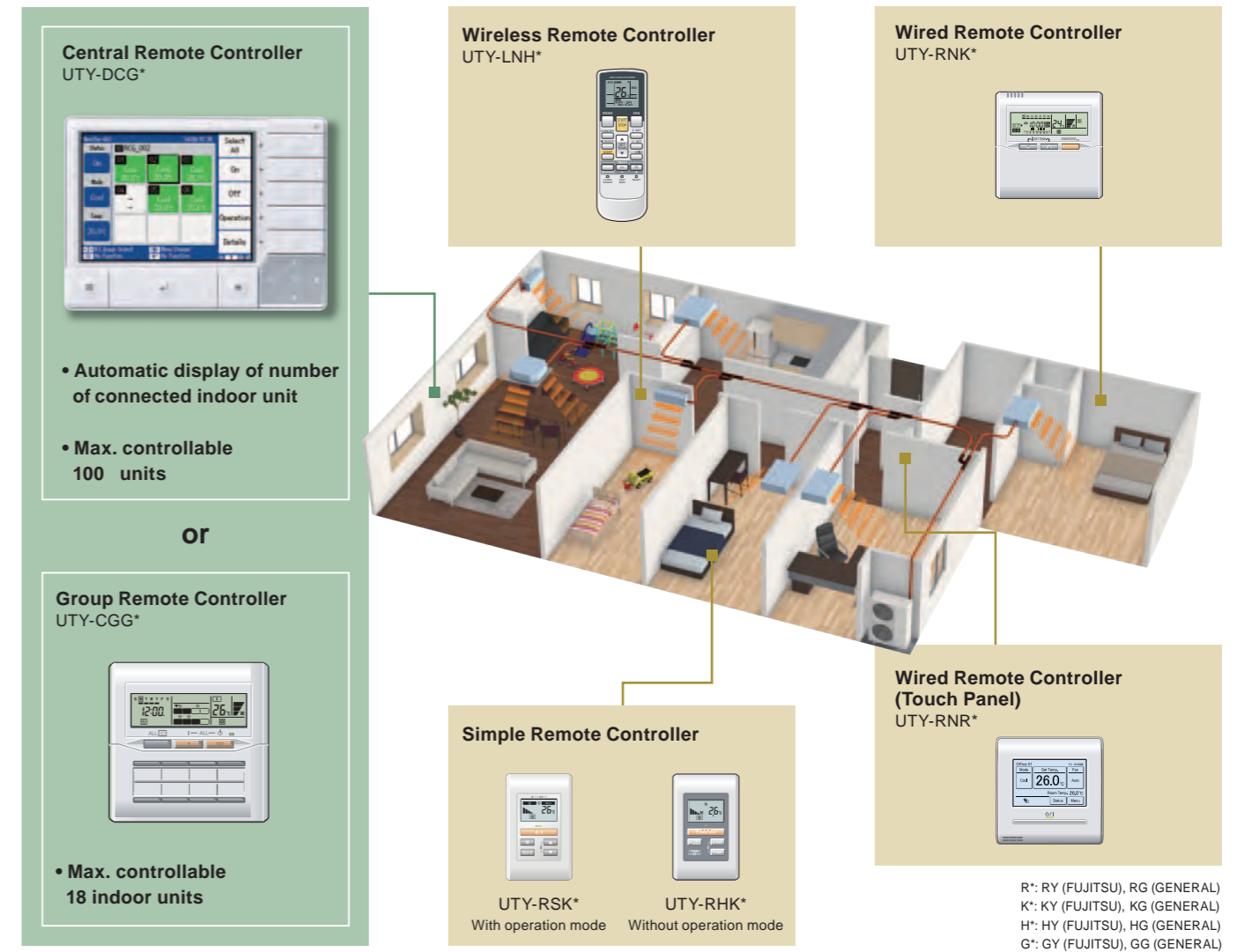

### Control system composition example

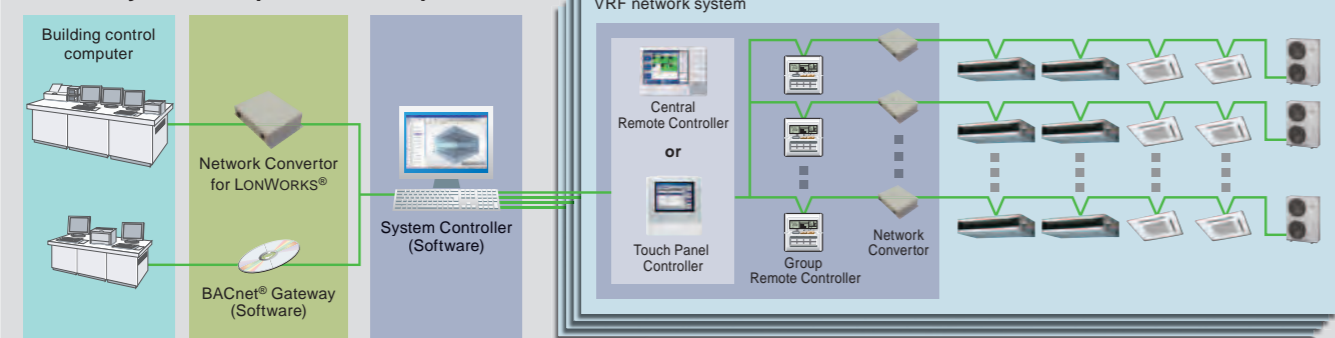

### Control system composition example

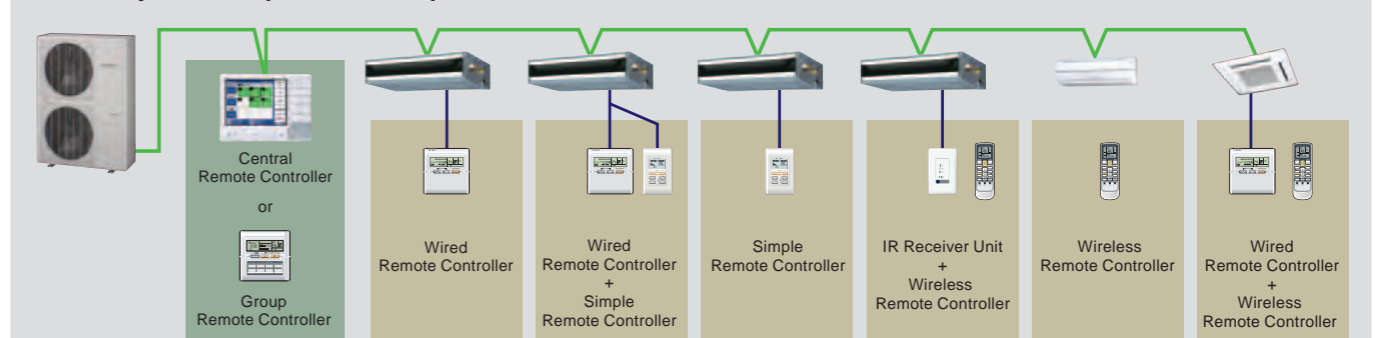

# More Design Flexibility

## Long Piping Length

Our advanced refrigerant control technology allows us to achieve a total refrigerant piping length of 180 m. This opens up new possibilities in system design.

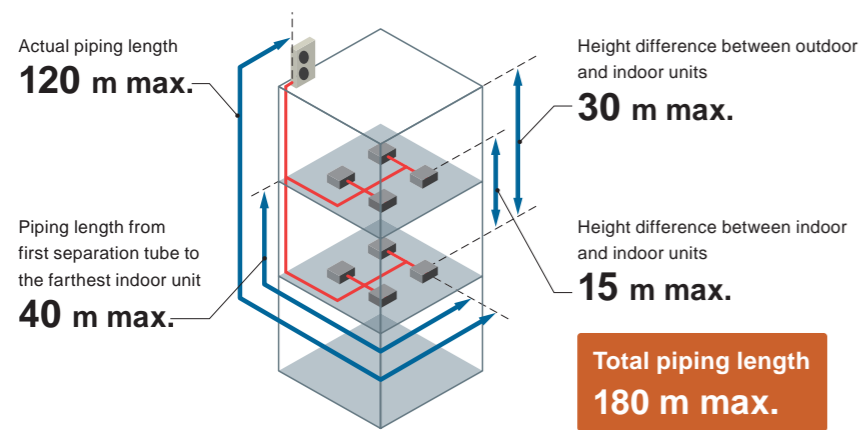

## High Capacity Connection

Number of connectable indoor unit

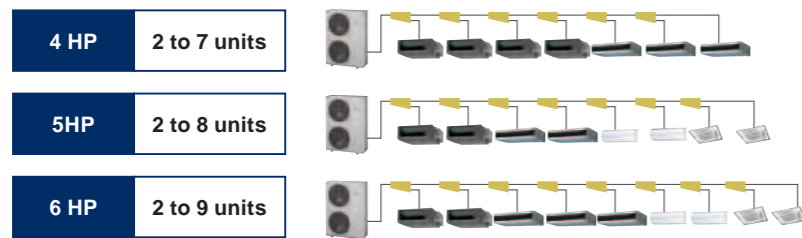

Indoor unit  
**12 types,  
48 models**

Connectable indoor unit capacity range  
**130 % max.**



## Wide operating range

Installation in extreme temperature conditions is possible due to an increase in operational range.

Cooling : -5°C~46°C  
Heating : -20°C~21°C

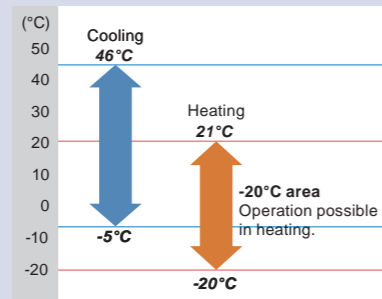

# Easy Installation

## Easier Installation

### Easy piping connection

Improvement of the reliability by decreasing the flare connection.

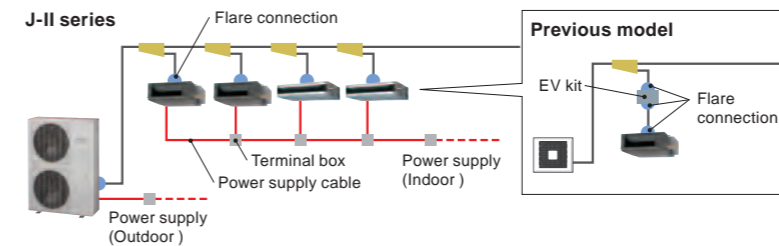

### Easy wiring connection

- Decreasing wiring mistakes by using non-polar 2 wires. (Remote controller cable is 3 wires)
- Improvement of wiring installation by common with V-II power supply method.

### Flexible installation of outdoor unit

Corresponds to the outdoor unit concentration installation.

Reduced installation intervals by front access

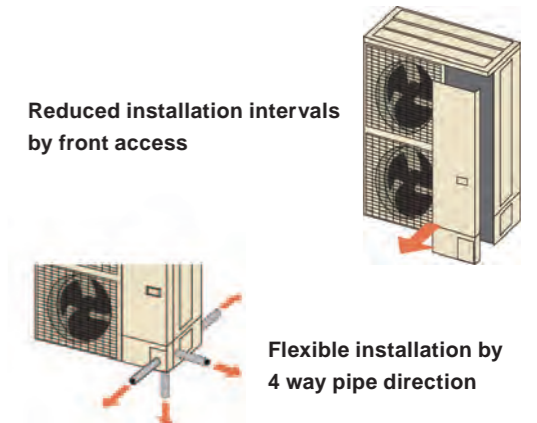

## Convenient Commissioning Support

### Automatic address setting function

The address of each indoor unit can be automatically set by button switch of outdoor unit.

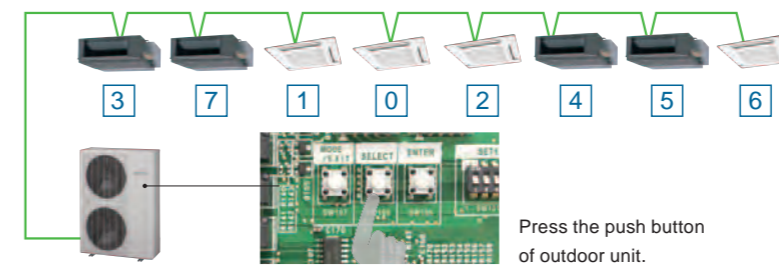

### Connection check function

Possible to confirm whether wiring connection and address setting are correct by check run function for a short time.

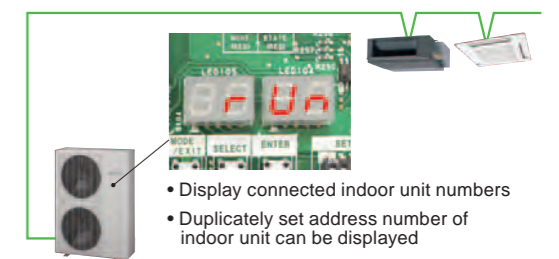

## Easy to connect with V-II communication system

It is possible to connect directly with the transmission cable of the V-II system without convertor.

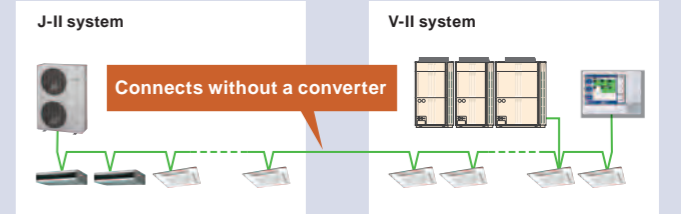

# Easy Maintenance

## Design for Easy Maintenance

### Easy to read 7-segment LED

Confirm detail operational and trouble status without using specific equipment

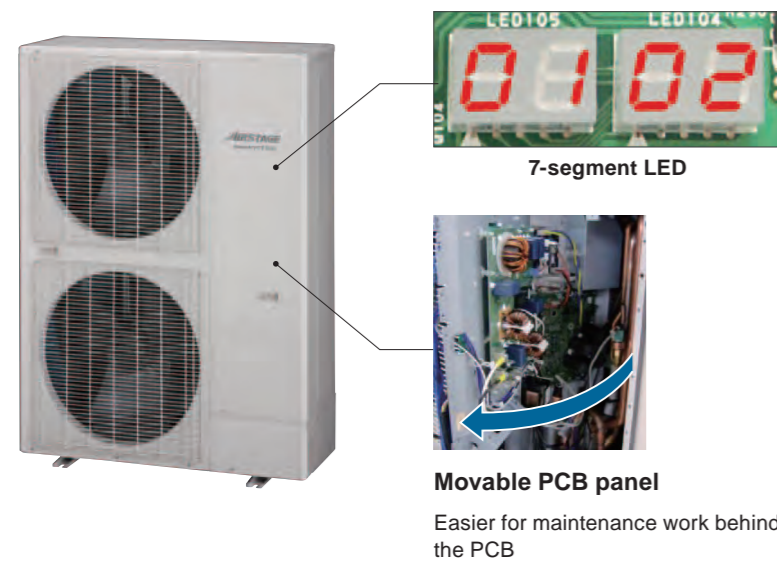

### Error status can be checked easily via the indoor unit wired controller

An error code is displayed on a liquid crystal screen.

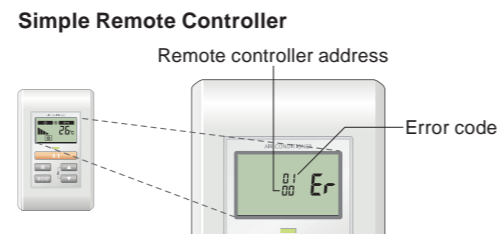
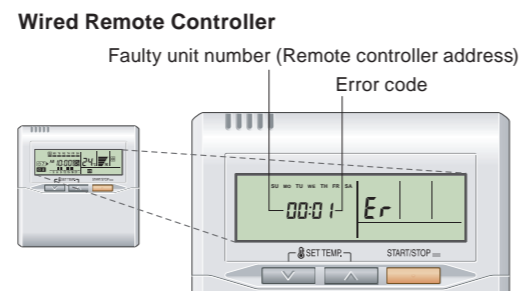

## Emergency Stop Function

Emergency alarm can be received by indoor, outdoor units, Central Remote Controller or Touch Panel Controller when they received it, all units will be stopped.

**Note :** In case of received Emergency alarm by Indoor / outdoor unit : All units connected within same refrigerant system will be stopped.  
Central Remote Controller or Touch Panel Controller : all units connected within VRF network system with Central Remote Controller or Touch Panel Controller will be stopped.

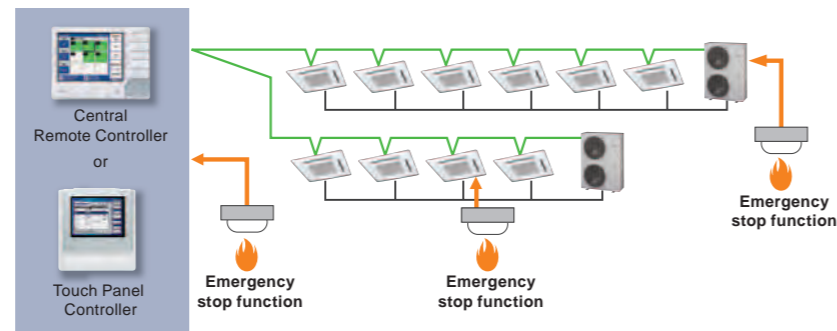

## Trouble diagnosis by Service Tool

### Connection to Service Tool

- Detail operation status and recent error history can be checked and analyzed by using Service Tool.
- Last 5 min. operation memory can be also recorded.

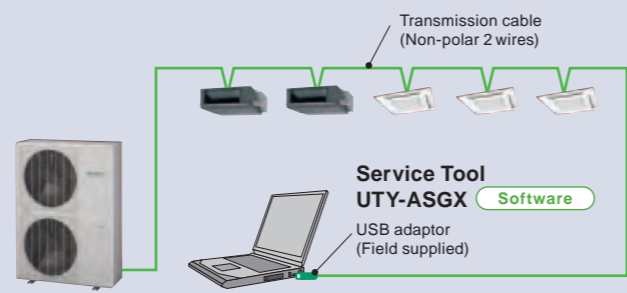
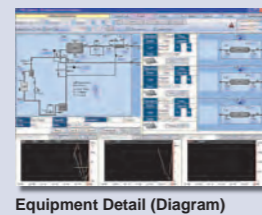

## Specifications

Model name		AJ*A40LALH	AJ*A45LALH	AJ*A54LALH
Capacity range	HP	4	5	6
Max.connectable indoor unit*1		7	8	9
Power source		1Ø, ~230V, 50Hz		
Capacity	Cooling	12.1	14.0	15.5
	Heating	13.6	16.0	18.0
Input power	Cooling	3.25	3.89	4.49
	Heating	3.17	3.81	4.56
EER	Cooling	3.72	3.60	3.45
COP	Heating	4.29	4.20	3.95
Air flow rate	m <sup>3</sup> /h	6,200	6,400	6,900
Sound pressure level	Cooling	50	51	53
	Heating	52	53	55
Heat exchanger fin		Blue fin		
Dimensions (HxWxD)	mm	1,334 x 970 x 370		
Weight	kg	117		
Refrigerant charge	kg	4.8	5.3	
Connection pipe diameter	Liquid	9.52		19.05
	Gas	15.88		
Operation temperature range	Cooling	-5 to 46		
	Heating	-20 to 21		

Note : Specifications are based on the following conditions.  
Cooling : Indoor temperature of 27°CDB / 19°CWB, and outdoor temperature of 35°CDB / 24°CWB.  
Heating : Indoor temperature of 20°CDB / (15°CWB), and outdoor temperature of 7°CDB / 6°CWB.  
Pipe length : 7.5 m; Height difference between outdoor unit and indoor unit : 0 m.  
The protective function might work when using it outside the operation range.

AJ\* : AJY (FUJITSU), AJH (GENERAL)

## Dimensions

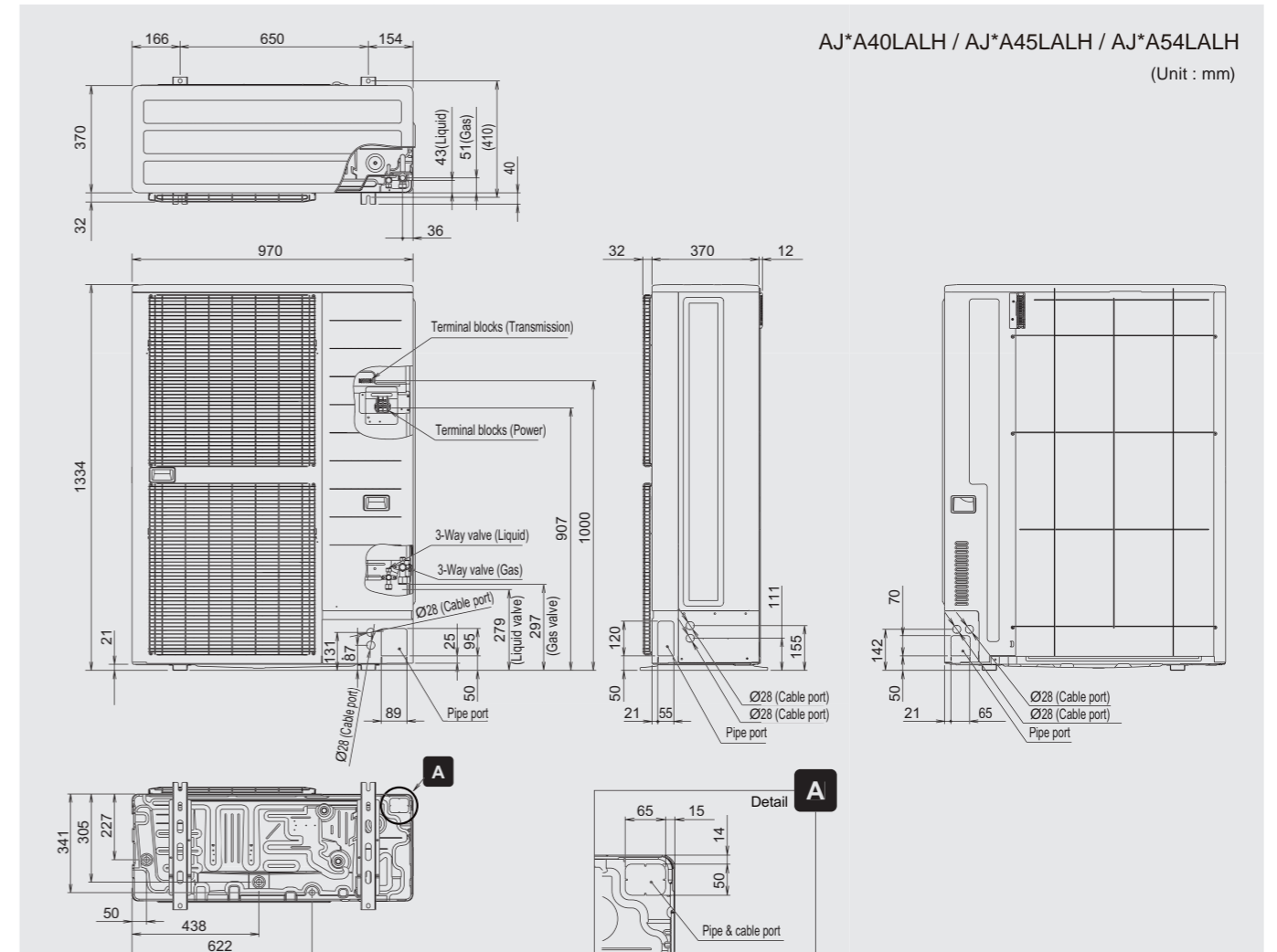













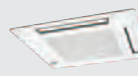
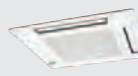
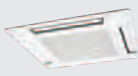
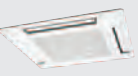









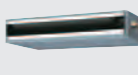

















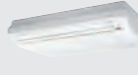

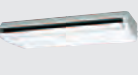
AJ\* : AJY (FUJITSU), AJH (GENERAL)

# Indoor Unit Lineup

Comprehensive range of indoor units of variety design and capacity ranges available which can be selected to suit any air conditioning needs.

12 Types, 48 Models, Capacity range from 2.2kW to 14.0kW

Capacity range (kW)		2.2	2.8	3.6	4.5	5.6	7.1	9.0	11.2	12.5	14.0
Model code		7	9	12	14	18	24	30	36	45	54
Cassette	Compact Cassette	 AUXB07GALH	 AUXB09GALH	 AUXB12GALH	 AUXB14GALH	 AUXB18GALH	 AUXB24GALH				
	Cassette					 AUXD18GALH	 AUXD24GALH	 AUXA30GALH	 AUXA36GALH	 AUXA45GALH	 AUXA54GALH
Duct	Low Static Pressure Duct	 ARXB07GALH	 ARXB09GALH	 ARXB12GALH	 ARXB14GALH	 ARXB18GALH					
	Slim Duct (Drain pump internal)	 ARXD07GALH	 ARXD09GALH	 ARXD12GALH	 ARXD14GALH	 ARXD18GALH	 ARXD24GALH				
	Medium Static Pressure Duct						 ARXA24GBLH	 ARXA30GBLH	 ARXA36GBLH	 ARXA45GBLH	
	High Static Pressure Duct							 ARXC36GATH	 ARXC45GATH		
Floor	Floor (*Same as Ceiling models)			 AB*A12GATH	 AB*A14GATH	 AB*A18GATH	 AB*A24GATH				
	Concealed Floor (*Same as Low Static Pressure Duct models)	 ARXB07GALH	 ARXB09GALH	 ARXB12GALH	 ARXB14GALH	 ARXB18GALH					
	Slim Concealed Floor (*Same as Slim Duct models)	 ARXD07GALH	 ARXD09GALH	 ARXD12GALH	 ARXD14GALH	 ARXD18GALH	 ARXD24GALH				
Ceiling	Ceiling			 AB*A12GATH	 AB*A14GATH	 AB*A18GATH	 AB*A24GATH	 AB*A30GATH	 AB*A36GATH	 AB*A45GATH	 AB*A54GATH
Wall Mounted	Wall Mounted	 AS*A07GACH	 AS*A09GACH	 AS*A12GACH	 AS*A14GACH	 AS*A18GACH	 AS*A24GACH	 AS*A30GACH			
	Wall Mounted (EEV external)	 AS*E07GACH	 AS*E09GACH	 AS*E12GACH	 AS*E14GACH	With this model, connection of EV kit is necessary.					

AB\* : ABY(FUJITSU), ABH(GENERAL) AS\* : ASY(FUJITSU), ASH(GENERAL)



# Compact Cassette

Models

- AUXB07GALH
- AUXB09GALH
- AUXB12GALH
- AUXB14GALH
- AUXB18GALH
- AUXB24GALH

Compact size panel design that fits standard ceiling panel (600x600mm)



## 2-stage turbo fan

High efficiency design by 2 stage structure

An evenly spread air distribution across the heat exchanger is possible due to the new 2 stage turbo fan which produces two separate airflow streams.

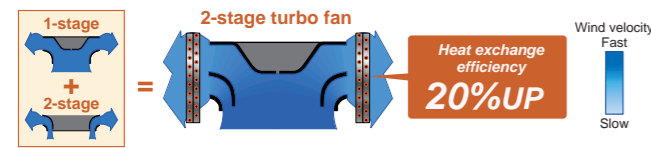

### Previous turbo fan

In the case of a previous fan, the air outlet range was narrow as the airflow moved to the motor side which meant the velocity of air passing through the heat exchanger was uneven.



## Quiet quality

Optimization of wing form (laminar wing type) and wing number (7 blades each)

Designed by CFD-analysis (fluid) simulations

### Adoption of laminar wing

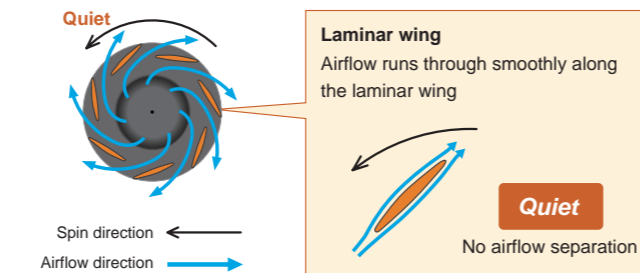

## Improvement of the airflow distribution

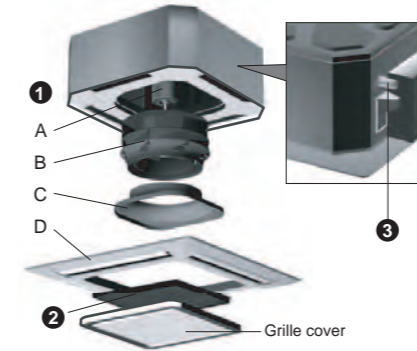

### 1 Maintenance of fan motor and fan

Maintenance of the fan motor and fan can be done easily after taking off the panel as the bell mouth of the fan can be removed easily.

A : Fan motor B : 2-stage turbo fan  
C : Bell-mouth D : Panel

### 2 Long life filter : standard equipment

### 3 Adaptation of transparent drainage parts

During installation, maintenance and operation, the drain pump and kit can be checked easily.

## Compact design

World's first 24,000Btu model in the compact cassette category (Easy installation by taking off ceiling panel of 600 x 600 size)

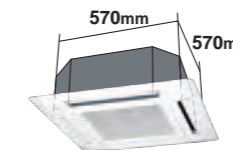

## High lift drain pump

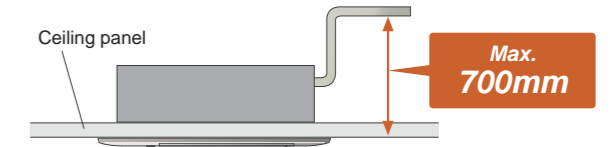

## High ceiling mode

The compact cassette can be installed up to a height of 3.0m (12/14/18/24).

Model code	The maximum height from floor to ceiling (m)	
	Standard mode	High ceiling mode
07	2.7	—
09	2.7	—
12	2.7	3.0
14	2.7	3.0
18	2.7	3.0
24	2.7	3.0

## Optional parts

- Air Outlet Shutter Plate : UTR-YDZB
- Insulation Kit for High Humidity : UTZ-KXGC
- Fresh Air Intake Kit : UTZ-VXAA

## Specifications

Model name		AUXB07GALH	AUXB09GALH	AUXB12GALH	AUXB14GALH	AUXB18GALH	AUXB24GALH
Power source		230V ~, 50Hz					
Capacity	Cooling	2.2	2.8	3.6	4.5	5.6	7.1
	Heating	2.8	3.2	4.1	5.0	6.3	8.0
Input power		W					
Airflow rate	High	540	550	600	680	710	1,030
	Med	450	450	530	590	580	830
	Low	350	350	390	390	400	450
Sound pressure level	High	34	35	37	38	41	50
	Med	30	30	34	34	35	44
	Low	25	25	27	27	27	30
Dimensions (H x W x D)		mm 245 x 570 x 570					
Weight		kg 15				kg 17	
Connection pipe diameter	Liquid (Flare)	mm ø6.35				mm ø9.52	
	Gas (Flare)	mm ø12.70				mm ø15.88	
	Drain	mm ø25 (I.D.) ; ø32 (O.D.)					
Cassette Grille	Model name	UTG-UF°C-W					
	Dimensions (H x W x D)	mm 50 x 700 x 700					
	Weight	kg 2.6					

F\* : FY (FUJITSU) ; FG (GENERAL)  
Note : Specifications are based on the following conditions.

Cooling : Indoor temperature of 27°CDB / 19°CWB, and outdoor temperature of 35°CDB / 24°CWB.  
Heating : Indoor temperature of 20°CDB / (15°CWB), and outdoor temperature of 7°CDB / 6°CWB.  
Pipe length : 7.5 m; Height difference between outdoor unit and indoor unit : 0 m. Voltage : 230 [V].

## Dimensions (Unit : mm)

Models: AUXB07 / AUXB09 / AUXB12 / AUXB14 / AUXB18 / AUXB24

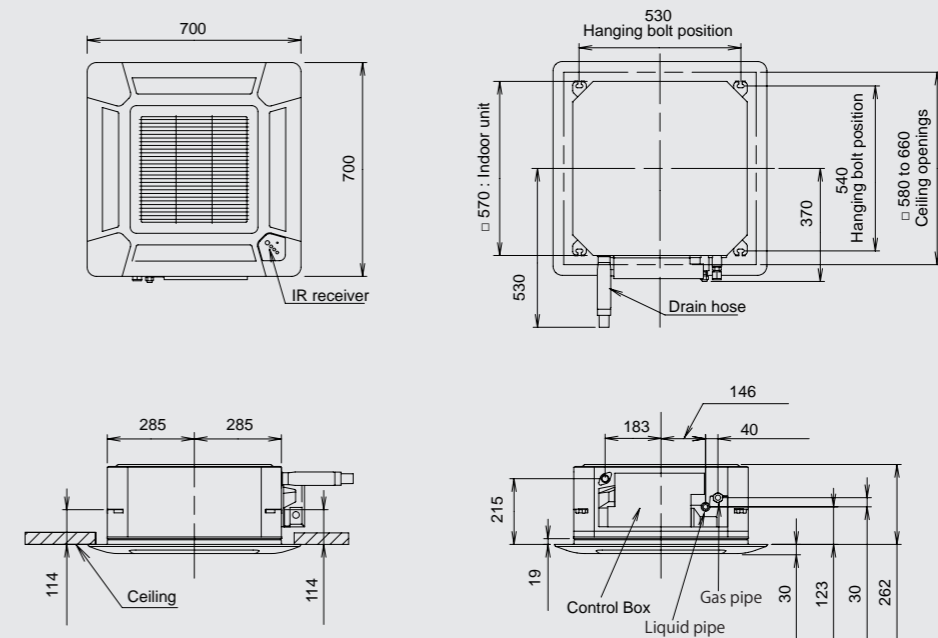

# Cassette

Models

- AUXD18GALH
- AUXD24GALH
- AUXA30GALH
- AUXA36GALH
- AUXA45GALH
- AUXA54GALH

Powerful, wide airflow and quiet operation



## High efficiency turbo fan with 3-dimensional blade

High efficiency airflow distribution has been achieved by the introduction of a 3 dimensional blade which increases the air passing over the heat exchanger.

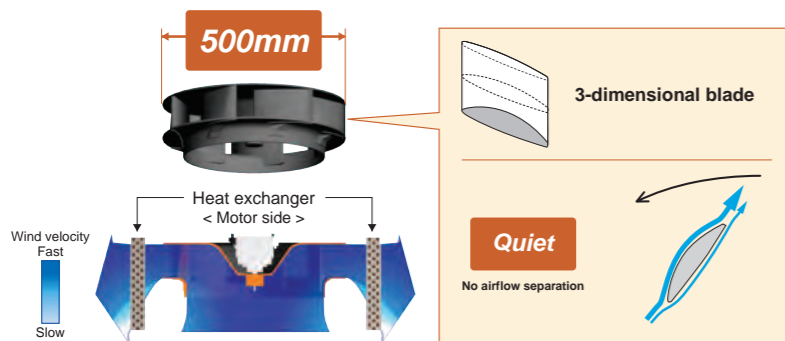

Previous turbo fan

Air passing through the heat exchanger was uneven and the air would only flow close to the ceiling.

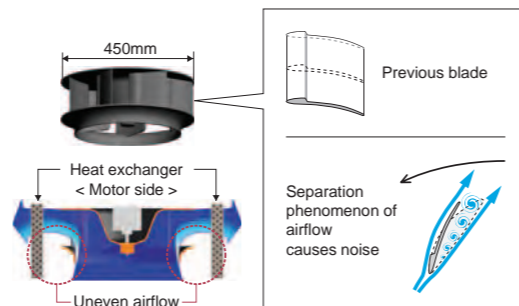

← : Spin direction → : Airflow direction ••••• : Turbulent flow noise

## Improvement of the airflow distribution

The louvre design distributes air leaving a space between the chassis and the ceiling allowing for far and wide air flow distribution.

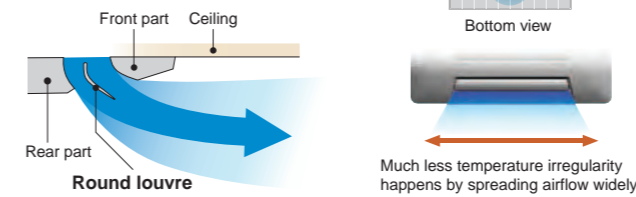

## Adjustment of hanger position is possible after installation

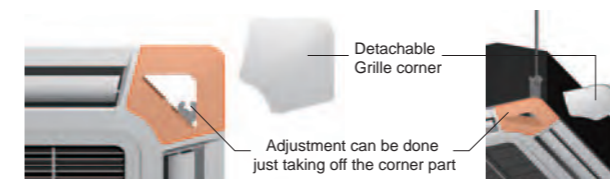

## One way aperture installation

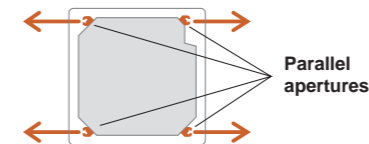

## High lift drain pump

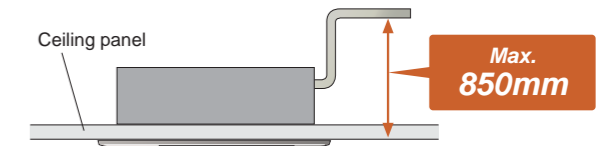

## High ceiling mode

This cassette can be installed up to a height of 4.2m (36/45/54).

Model code	The maximum height from floor to ceiling (m)	
	Standard mode	High ceiling mode
18	3.0	3.5
24	3.0	3.5
30	3.2	3.6
36	3.2	4.2
45	3.2	4.2
54	3.2	4.2

## Optional parts

- IR Receiver Unit : UTY-LRH\*B1
  - Air Outlet Shutter Plate : UTR-YDZC
  - Panel Spacer : UTG-BGYA-W
  - Insulation Kit for High Humidity : UTZ-KXGA / UTZ-KXGB
  - Wide Panel : UTG-AGYA-W
  - Fresh Air Intake Kit : UTZ-VXGA
- H\*: HY(FUJITSU), HG(GENERAL)

## Specifications

Model name	AUXD18GALH	AUXD24GALH	AUXA30GALH	AUXA36GALH	AUXA45GALH	AUXA54GALH	
Power source	230V ~, 50Hz						
Capacity	Cooling	5.6	7.1	9.0	11.2	12.5	14.0
	Heating	6.3	8.0	10.0	12.5	14.0	16.0
Input power	W	39	46	59	80	99	119
Airflow rate	High	1,150	1,280	1,600	1,800	1,900	2,000
	Med	940	1,040	1,300	1,300	1,370	1,370
	Low	870	870	1,100	1,100	1,100	1,100
Sound pressure level	High	36	38	40	44	46	47
	Med	30	33	38	38	39	39
	Low	29	29	33	33	33	33
Dimensions (H x W x D)	mm	246 x 840 x 840		288 x 840 x 840			
Weight	kg	22		27			
Connection pipe diameter	Liquid (Flare)	ø9.52					
	Gas (Flare)	ø15.88		ø19.05			
	Drain	ø25 (I.D.) ; ø32 (O.D.)					
Cassette Grille	Model name	UTG-UG*A-W					
	Dimensions (H x W x D)	50 x 950 x 950					
	Weight	5.5					

G\* : GY(FUJITSU) ; GG(GENERAL)  
 Note : Specifications are based on the following conditions.

Cooling : Indoor temperature of 27°CDB / 19°CWB, and outdoor temperature of 35°CDB / 24°CWB.  
 Heating : Indoor temperature of 20°CDB / (15°CWB), and outdoor temperature of 7°CDB / 6°CWB.  
 Pipe length : 7.5 m; Height difference between outdoor unit and indoor unit : 0 m. Voltage : 230 [V].

## Dimensions (Unit : mm) ( ) : AUXD18 / AUXD24

Models: AUXD18 / AUXD24 (Slim type)  
 AUXA30 / AUXA36 / AUXA45 / AUXA54

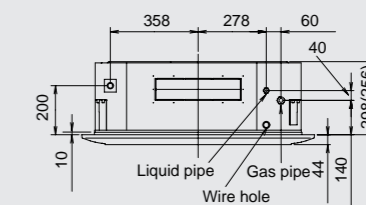
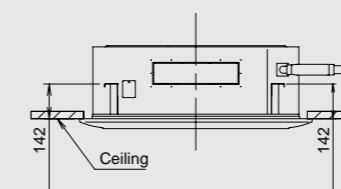
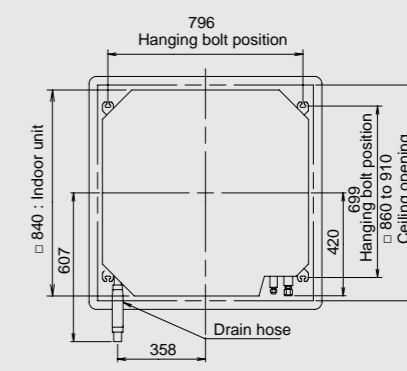
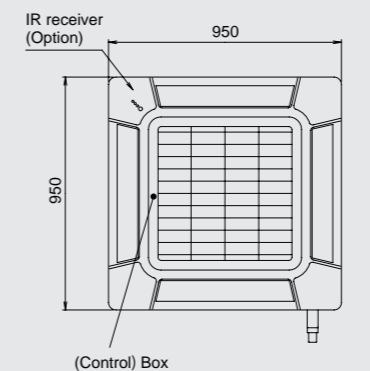

# Low Static Pressure Duct / Concealed Floor

Models

- ARXB07GALH
- ARXB09GALH
- ARXB12GALH
- ARXB14GALH
- ARXB18GALH

Small and compact indoor unit suitable for many applications

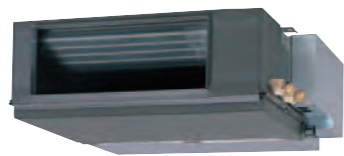

ARXB07GALH  
ARXB09GALH

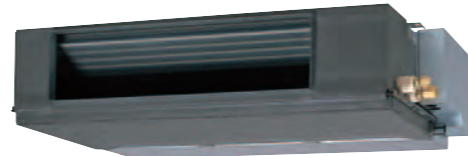

ARXB12GALH  
ARXB14GALH  
ARXB18GALH

Concealed Floor



## Low noise level

A low noise level has been achieved for each capacity

Model		7	9	12	14	18
Static pressure range	Pa	0 to 50				
Noise level (Low speed)	dB(A)	24	27	25	30	30

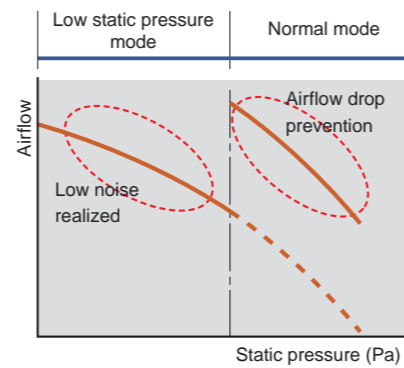

## Specifications

Model name			ARXB07GALH	ARXB09GALH	ARXB12GALH	ARXB14GALH	ARXB18GALH	
Power source			230V ~, 50Hz					
Capacity	Cooling	kW	2.2	2.8	3.6	4.5	5.6	
	Heating	kW	2.8	3.2	4.0	5.0	6.3	
Input power	W		46	55	63	90	96	
Airflow rate	High	m <sup>3</sup> /h	370	440	590	800	890	
	Med		310	370	500	750	810	
	Low		280	340	450	700	730	
Static pressure range	Pa		0 to 50	0 to 50	0 to 50	0 to 50	0 to 50	
Standard static pressure	Pa		25	25	25	25	25	
Sound pressure level	High	dB(A)	29	31	30	33	36	
	Med		26	29	28	32	34	
	Low		24	27	25	30	30	
Dimensions (H x W x D)	mm		217 x 663 x 595			217 x 953 x 595		
Weight	kg		15			22		
Connection pipe diameter	Liquid (Flare)	mm	ø6.35				ø9.52	
	Gas (Flare)		ø12.70				ø15.88	
	Drain		ø25 (I.D.) ; ø32 (O.D.)					

Note : Specifications are based on the following conditions.

Cooling : Indoor temperature of 27°CDB / 19°CWB, and outdoor temperature of 35°CDB / 24°CWB.  
 Heating : Indoor temperature of 20°CDB / (15°CWB), and outdoor temperature of 7°CDB / 6°CWB.  
 Pipe length : 7.5 m; Height difference between outdoor unit and indoor unit : 0 m.

## Compact design

Ultra-slim duct air conditioner for easy installation

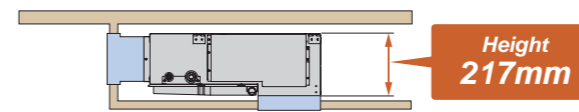

Slim size (217mm) allows installation even where the space behind the ceiling is narrow.

## Two-direction drain piping

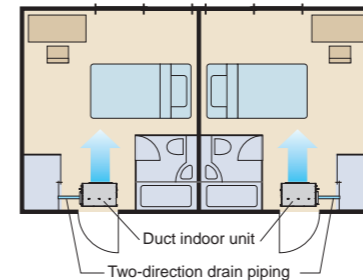

## Air-intake

Air intake direction can be selected to match the installation site.

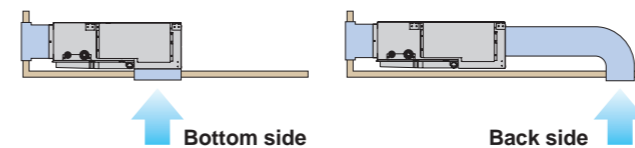

## Flexible installation

Ceiling concealed

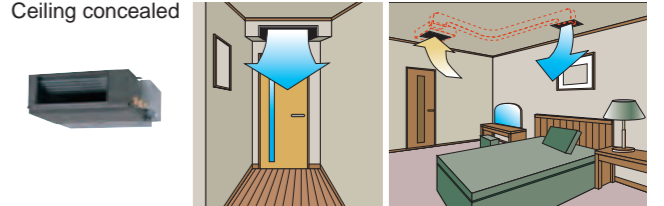

Floor concealed

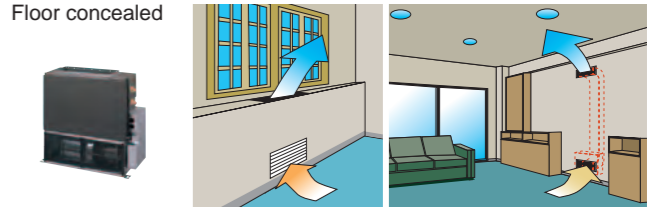

Filter (Accessory)

ARXB07 / ARXB09

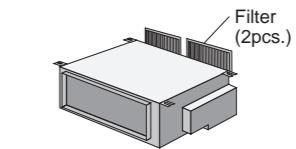

ARXB12 / ARXB14 / ARXB18

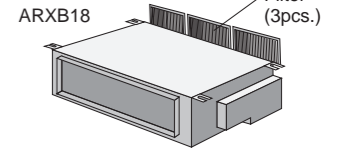

## Optional parts

Remote Sensor Unit : UTY-XSZX

IR Receiver Unit : UTB-YWC

Drain Pump Unit : UTZ-PX1BBA

## Dimensions (Unit : mm) ( ) : AR7 / AR9

Models: ARXB07 / ARXB09 / ARXB12 / ARXB14 / ARXB18

\*Service accessibility must be allowed for when installing the product.  
 Please consult the installation manual for the necessary service access size.

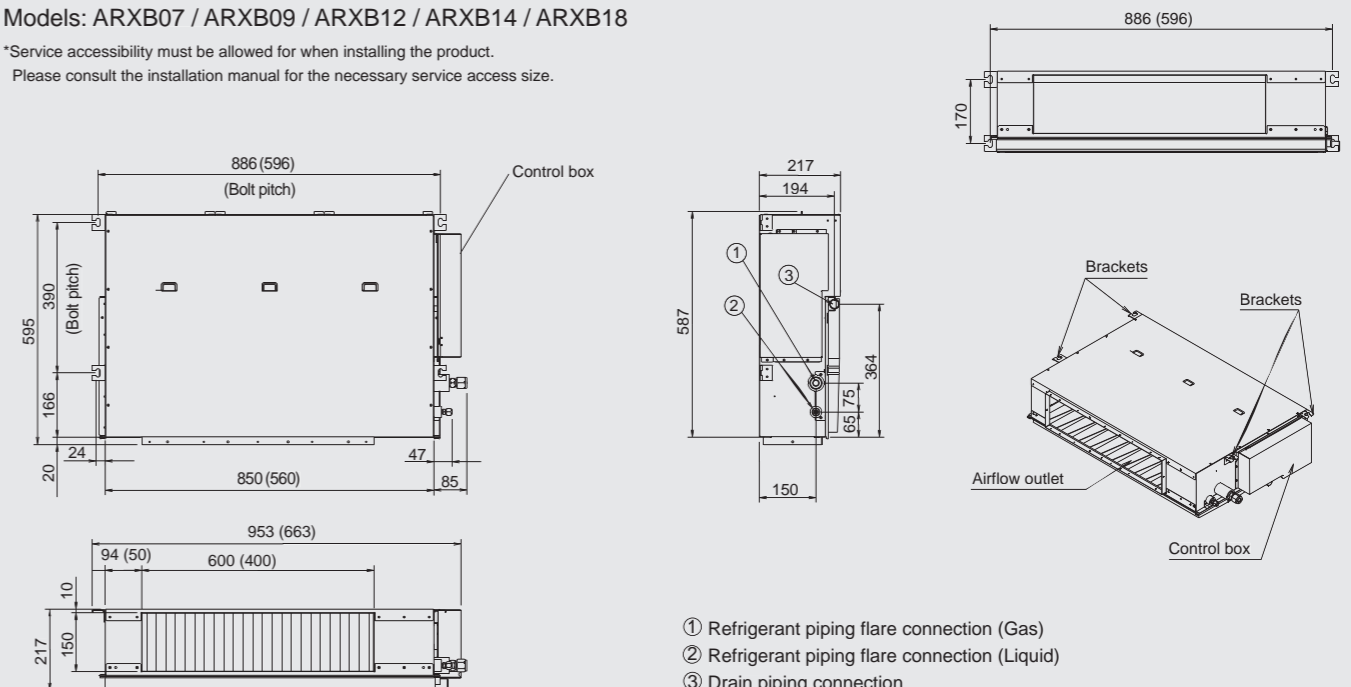

# Slim Duct / Slim Concealed Floor

Models (Drain pump internal model)

- ARXD07GALH
- ARXD09GALH
- ARXD12GALH
- ARXD14GALH
- ARXD18GALH
- ARXD24GALH



Slim design and wide range of static pressure for flexible installation.

Slim Concealed Floor



## Slim design

This model is slim design, it can install at the place where a ceiling is narrow.

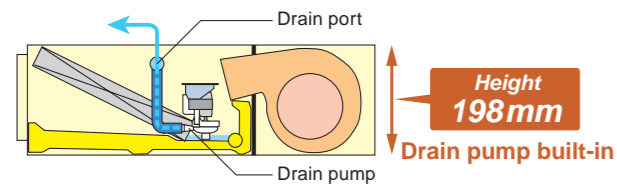

## Air-intake

Air intake direction can be selected to match the installation site.

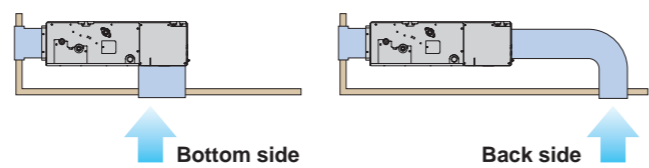

## High lift drain pump

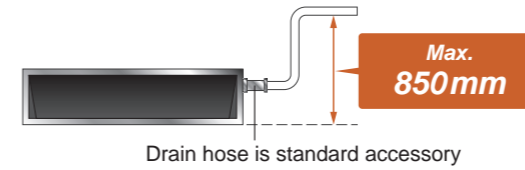

## Selectable with a wide range of static pressure

By using DC fan motor, it is possible to change of static pressure range 0 to 90Pa. The change of static pressure range is possible by remote controller.

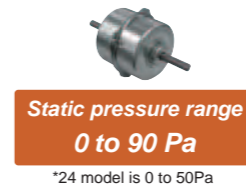

## Flexible installation

Ceiling concealed

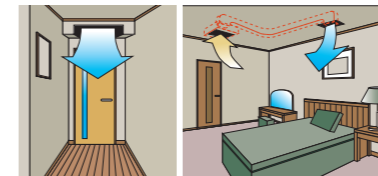

Floor concealed

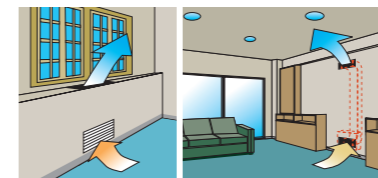

## Auto Louver Grille Kit (Option)

Simple flat Auto Louver will provide comfort airflow and harmonize with luxury interior.

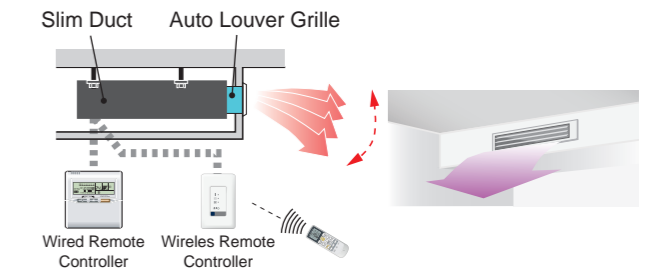

## Filter (Accessory)

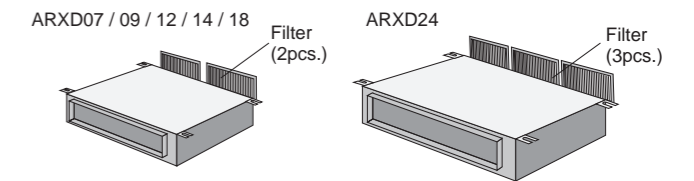

## Optional parts

- Remote Sensor Unit : UTY-XSZX
- IR Receiver Unit : UTB-YWC
- Auto Louver Grille Kit : UTD-GXSA-W (for ARXD07/09/12/14GALH)
- UTD-GXSB-W (for ARXD18GALH)
- UTD-GXSC-W (for ARXD24GALH)

## Specifications

Model name	ARXD07GALH	ARXD09GALH	ARXD12GALH	ARXD14GALH	ARXD18GALH	ARXD24GALH	
Power source	230V ~, 50Hz						
Capacity	Cooling	2.2	2.8	3.6	4.5	5.6	7.1
	Heating	2.8	3.2	4.0	5.0	6.3	8.0
Input power	W	44	50	54	92	83	122
Airflow rate	High	550	600	600	800	940	1,330
	Med	490	550	510	710	840	1,240
	Low	440	480	450	610	750	1,100
Static pressure range	Pa	0 to 90	0 to 90	0 to 90	0 to 90	0 to 90	0 to 50
Standard static pressure	Pa	25	25	25	25	25	25
Sound pressure level	High	28	29	30	34	34	35
	Med	25	26	27	32	32	32
	Low	22	24	24	28	28	29
Dimensions (H x W x D)	mm	198 x 700 x 620			198 x 900 x 620	198 x 1,100 x 620	
Weight	kg	17		18	22	26	
Connection pipe diameter	Liquid (Flare)	ø6.35			ø9.52		
	Gas (Flare)	ø12.70			ø15.88		
	Drain	ø25 (I.D.) ; ø32 (O.D.)					

Note : Specifications are based on the following conditions.

Cooling : Indoor temperature of 27°CDB / 19°CWB, and outdoor temperature of 35°CDB / 24°CWB.  
 Heating : Indoor temperature of 20°CDB / (15°CWB), and outdoor temperature of 7°CDB / 6°CWB.  
 Pipe length : 7.5 m; Height difference between outdoor unit and indoor unit : 0 m.

## Dimensions (Unit : mm)

Models: ARXD07 / ARXD09 / ARXD12 / ARXD14 / ARXD18 / ARXD24

\*Service accessibility must be allowed for when installing the product. Please consult the installation manual for the necessary service access size.

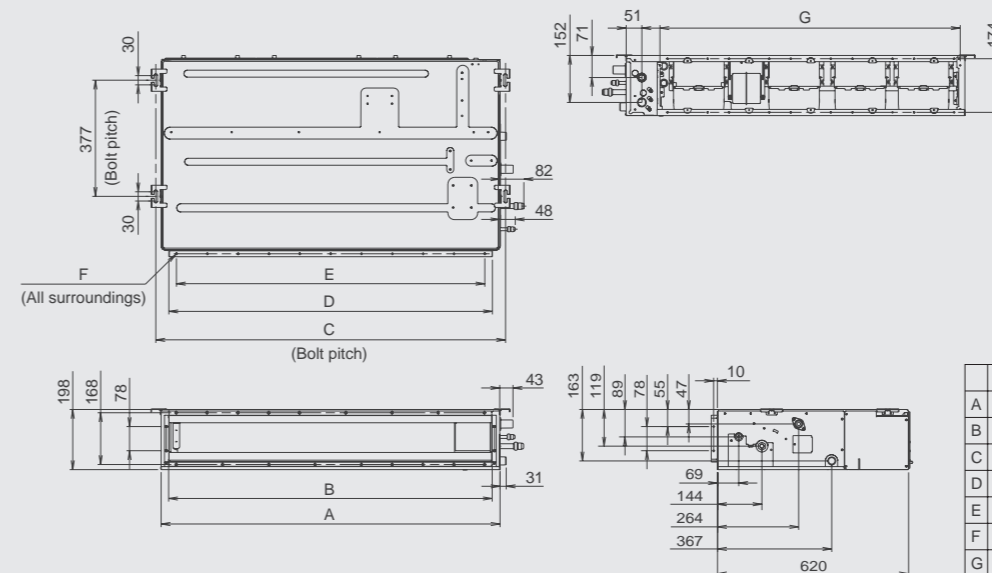

	ARXD07-14	ARXD18	ARXD24
A	700	900	1100
B	650	850	1050
C	734	934	1134
D	650	850	1050
E	P100x6=600	P100x8=800	P100x10=1000
F	18xø5	22xø5	26xø5
G	574	774	974

# Medium Static Pressure Duct

Models

- ARXA24GBLH
- ARXA30GBLH
- ARXA36GBLH
- ARXA45GBLH

Low energy consumption by DC fan motor.  
Selectable with a wide range of static pressure.



## Slim & Compact design

In the case of bottom return air connection, not only does the indoor unit design allow for installation in a narrow ceiling space of up to 270mm, Further space savings have been achieved by mounting the electrical control box internally inside the chassis.

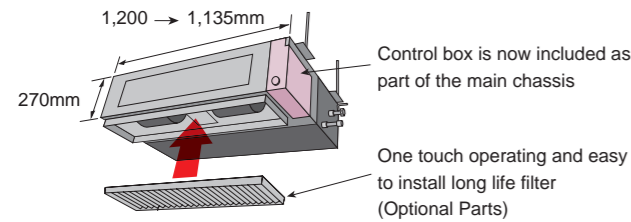

## Low energy consumption by high efficiency DC fan motor

Improved motor efficiency from previous model.

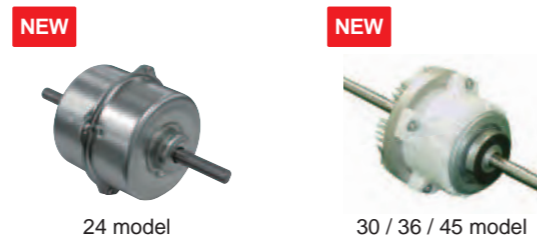

## Selectable with a wide range of static pressure

It is possible to change of static pressure range 0 to 150Pa.

Static pressure range  
0 to 150 Pa

## Can be installed for various location

It can be installed in such locations as high-rise condominiums by low static pressure design.

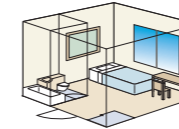

It can also be installed in wide spade when high static pressure is required, such as for offices.

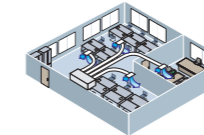

## Easy setting by using remote controller

The change of static pressure range is possible by remote controller



## Two-direction drain piping

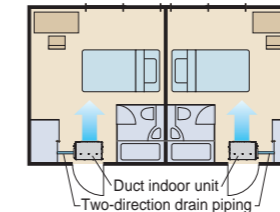

## Easy maintenance

See below for the case of rear suction type

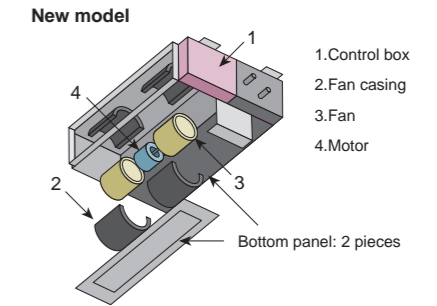

The maintenance of the motor and fan can be easily carried out by removing the rear panel and the lower part of the casing while leaving the main chassis installed.

## Installation styles

Embedded in Ceiling

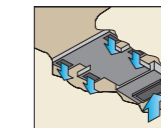

Hanging from Ceiling

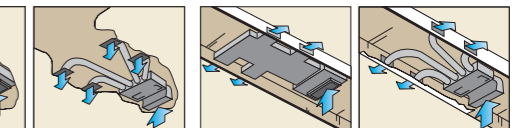

## Optional parts

- Remote Sensor Unit : UTY-XSZX
- Long Life Filter : UTD-LF25NA
- Flange (Square) : UTD-SF045T
- Flange (Round) : UTD-RF204
- IR Receiver Unit : UTB-YWC
- Drain Pump Unit : UTZ-PX1NBA

## Specifications

Model name	ARXA24GBLH	ARXA30GBLH	ARXA36GBLH	ARXA45GBLH	
Power source	230V ~, 50Hz				
Capacity	Cooling	7.1	9.0	11.2	12.5
	Heating	8.0	10.0	12.5	14.0
Input power	W	94	108	194	240
Airflow rate	High	1,280	1,410	1,840	1,970
	Med	990	1,280	1,600	1,860
	Low	840	1,150	1,470	1,640
Static pressure range	Pa	0 to 150	0 to 150	0 to 150	0 to 150
Standard static pressure	Pa	40	50	50	60
Sound pressure level	High	31	34	37	41
	Med	27	32	35	38
	Low	23	29	33	36
Dimensions (H x W x D)	mm	270 x 1,135 x 700			
Weight	kg	36	40		
Connection pipe diameter	Liquid (Flare)	ø9.52			
	Gas (Flare)	ø15.88	ø19.05		
	Drain	ø25 (I.D.) ; ø32 (O.D.)			

Note : Specifications are based on the following conditions.

Cooling : Indoor temperature of 27°CDB / 19°CWB, and outdoor temperature of 35°CDB / 24°CWB.  
Heating : Indoor temperature of 20°CDB / (15°CWB), and outdoor temperature of 7°CDB / 6°CWB.  
Pipe length : 7.5 m; Height difference between outdoor unit and indoor unit : 0 m.

## Dimensions (Unit : mm)

Models: ARXA24 / ARXA30 / ARXA36 / ARXA45

\*Service accessibility must be allowed for when installing the product.  
Please consult the installation manual for the necessary service access size.

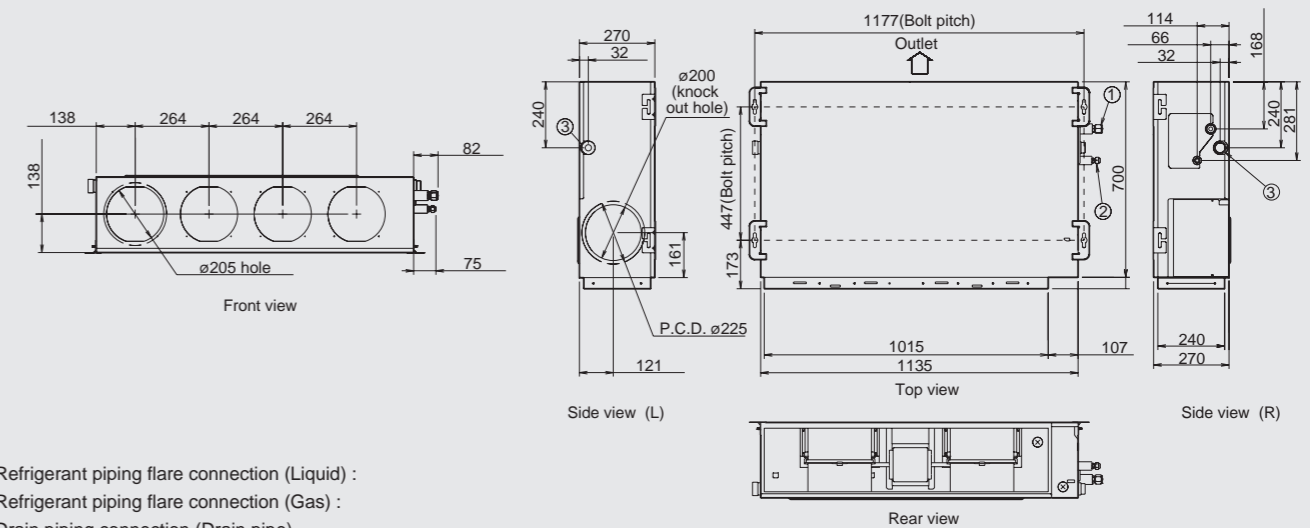

- ① Refrigerant piping flare connection (Liquid) :
- ② Refrigerant piping flare connection (Gas) :
- ③ Drain piping connection (Drain pipe)

# High Static Pressure Duct

Models

**ARXC36GATH**  
**ARXC45GATH**

These indoor units allow for high airflow quantities



ARXC36GATH  
ARXC45GATH

## Easy installation (Compact size & Lightweight)

Models : ARXC36

A compact size and lightweight indoor unit has been developed by reducing the basic chassis and the overall material weight.

**Volume**  
47.5%  
down

**Weight**  
42%  
down

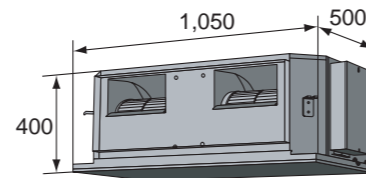

ARXC36GATH : 43kg (unit: mm)

## Low noise

Models : ARXC36 / ARXC45

Cutting off the corners of the conventional indoor unit front panel and fan casing, has enabled less turbulent air flow. Low noise is realized by adopting a plastic case and a plastic fan.

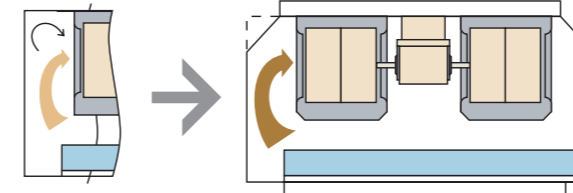

Previous model

New model  
(ARXC36GATH)

ARXC36GATH : Plastic fan [45dB(A)]

\* Model : Material  
(At 100Pa : Actual noise measurement value)

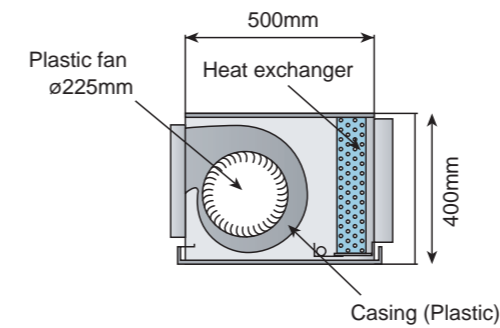

## Design also corresponding to high static pressure

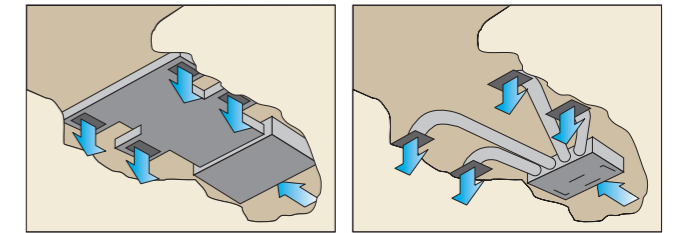
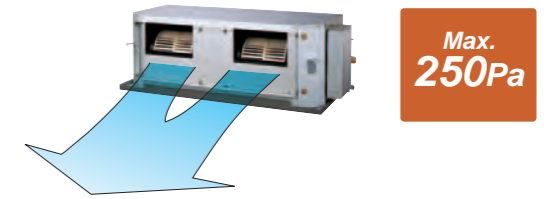

## Optional parts

Long-Life Filter : UTD-LF60KA  
IR Receiver Unit : UTB-YWC  
Remote Sensor Unit : UTY-XSZX

## Specifications

Model name		ARXC36GATH	ARXC45GATH
Power source		230V ~, 50Hz	
Capacity	Cooling	11.2	12.5
	Heating	12.5	14.0
Input power	W	405	715
Airflow rate	High	2,600	3,500
	Med	1,950	3,000
	Low	1,450	2,460
Static pressure range		100 to 200	100 to 250
Standard static pressure		100	100
Sound pressure level	High	45	49
	Med	38	45
	Low	32	42
Dimensions (H x W x D)		400 x 1,050 x 500	
Weight		43	46
Connection pipe diameter	Liquid	ø9.52 (Flare)	
	Gas	ø19.05 (Flare)	
	Drain	ø25 (I.D.) ; ø32 (O.D.)	

Note : Specifications are based on the following conditions.

Cooling : Indoor temperature of 27°CDB / 19°CWB, and outdoor temperature of 35°CDB / 24°CWB.  
Heating : Indoor temperature of 20°CDB / (15°CWB), and outdoor temperature of 7°CDB / 6°CWB.  
Pipe length : 7.5 m; Height difference between outdoor unit and indoor unit : 0 m.

## Dimensions (Unit : mm)

Models: ARXC36 / ARXC45

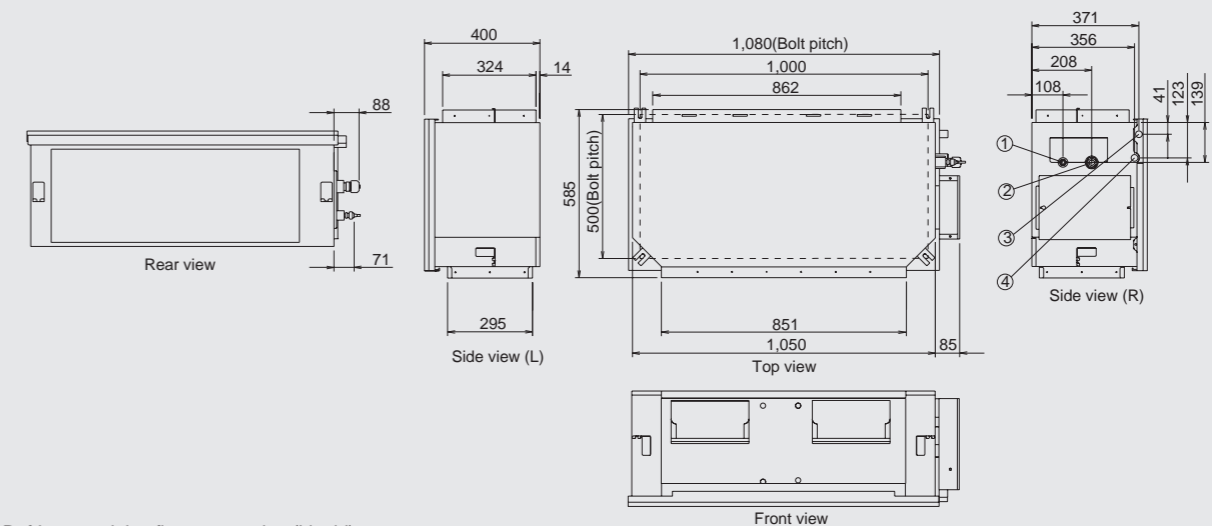

- ① Refrigerant piping flare connection (Liquid)
- ② Refrigerant piping flare connection (Gas)
- ③ Drain piping connection

# Floor / Ceiling

Models

- AB\*A12GATH
- AB\*A14GATH
- AB\*A18GATH
- AB\*A24GATH

The slim and lightweight design allow the unit to be suspended from the ceiling or installed on the floor. This type suits many room designs



Floor standing



## Double auto swing

A combination of up/down and right/left directional swing allows three-dimensional air direction control.

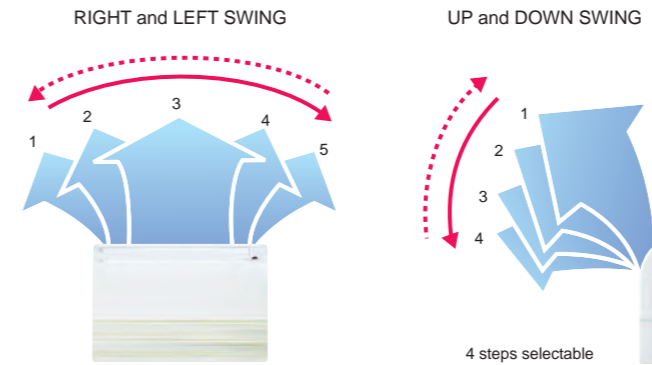

## Super vane

Double Louvre Super vane with newly developed special configuration boosts airflow sending cool air quickly to every corner of the room.

## Auto-closing louvre

When operation is stopped, the louvres will automatically close. (This function is available on all non-ducted models.)

## Compact design

Symmetrical, slim and compact design.

## Flexible installation

### Example for floor installation

Floor console



### Example for ceiling installation

Under ceiling



## High power DC fan motor

- High power
- Wide rotation range
- High efficiency

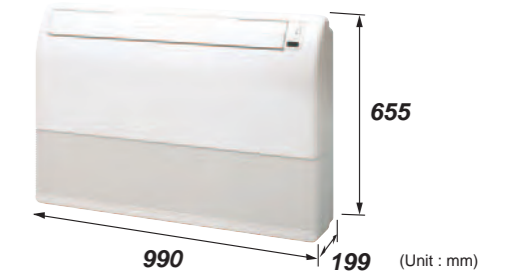
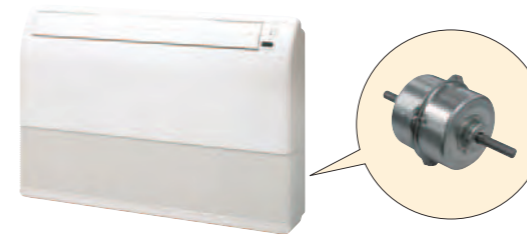

## Specifications

Model name		AB*A12GATH	AB*A14GATH	AB*A18GATH	AB*A24GATH
Power source		230V ~, 50Hz			
Capacity	Cooling	3.6	4.5	5.6	7.1
	Heating	4.0	5.0	6.3	8.0
Input power	W	30	42	74	99
Airflow rate	High	660	780	1,000	1,000
	Med	570	640	720	820
	Low	490	550	580	680
Sound pressure level	High	36	40	46	47
	Med	32	36	39	42
	Low	28	34	35	37
Dimensions (H x W x D)	mm	199 x 990 x 655			
Weight	kg	25	26	26	27
Connection pipe diameter	Liquid (Flare)	ø6.35		ø9.52	
	Gas (Flare)	ø12.70		ø15.88	
	Drain	ø25 (I.D.) ; ø32 (O.D.)			

AB\*: ABY(FUJITSU), ABH(GENERAL)

Note : Specifications are based on the following conditions.

Cooling : Indoor temperature of 27°CDB / 19°CWB, and outdoor temperature of 35°CDB / 24°CWB.

Heating : Indoor temperature of 20°CDB / (15°CWB), and outdoor temperature of 7°CDB / 6°CWB.

Pipe length : 7.5 m; Height difference between outdoor unit and indoor unit : 0 m.

Voltage : 230 [V].

## Dimensions (Unit : mm)

Models: AB\*A12 / AB\*A14 / AB\*A18 / AB\*A24

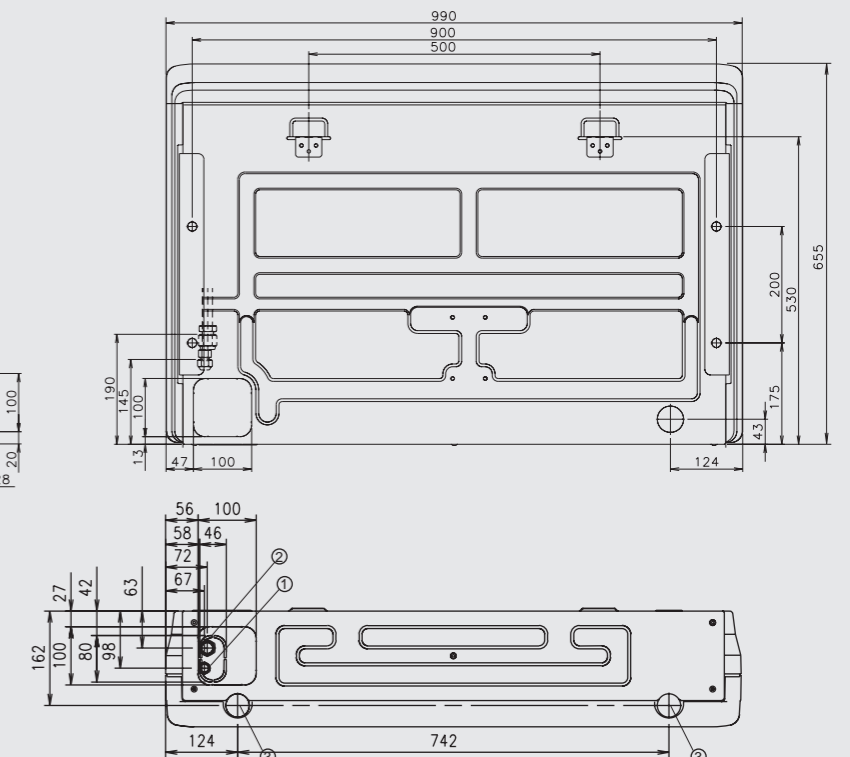
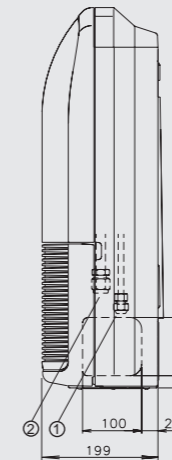

① Refrigerant piping flare connection (Liquid)

② Refrigerant piping flare connection (Gas)

③ Drain piping connection

# Ceiling

Models

- AB\*A30GATH
- AB\*A36GATH
- AB\*A45GATH
- AB\*A54GATH



Easily concealed in any installation

## Installation

**Open**

General installation pattern which suspends the indoor unit from the ceiling.

**Concealed**

Installation pattern where part of the indoor unit is embedded into the ceiling.

**Wall mounted**

Installation which fixes the indoor unit to the wall by the use of wall brackets (Field supplied). This type of installation can be used when the ceiling space is insufficient.

## Double auto swing and wide airflow

Auto airflow direction and auto swing

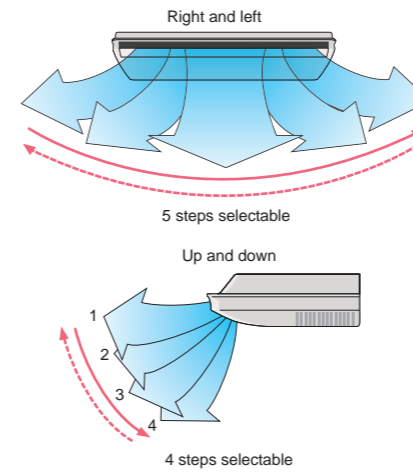

## Long airflow

Long Airflow ensures comfort to every corner of a large room.

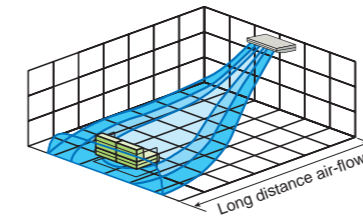

## Slim & Compact design

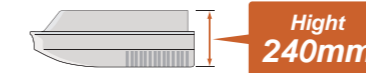

## High lift drain pump

Optional drain pump unit allows flexible installation design.

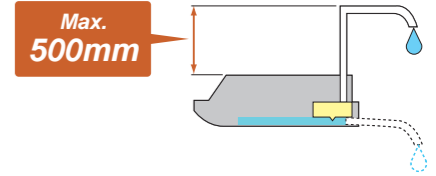

## Fresh air intake

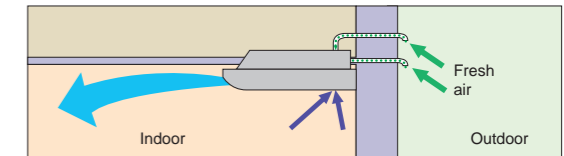

## High power DC fan motor

- High power
- Wide rotation range
- High efficiency

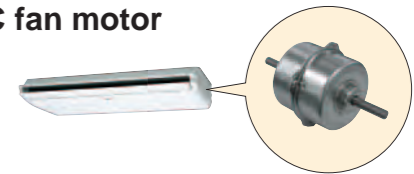

## Long-life filter

High Efficiency long-life filter doubles the life of the filter compared to standard filters.

## Optional parts

- Drain Pump Unit : UTR-DPB24T
- Flange : UTD-RF204

## Specifications

Model name		AB*A30GATH	AB*A36GATH	AB*A45GATH	AB*A54GATH
Power source		230V ~, 50Hz			
Capacity	Cooling	9.0	11.2	12.5	14.0
	Heating	10.0	12.5	14.0	16.0
Input power	W	66	85	131	180
Airflow rate	High	1,630	1,690	2,010	2,270
	Med	1,370	1,400	1,600	1,780
	Low	1,140	1,170	1,230	1,280
Sound pressure level	High	42	45	48	51
	Med	38	38	42	45
	Low	33	34	35	36
Dimensions (H x W x D)	mm	240 x 1,660 x 700			
Weight	kg	46		48	
Connection pipe diameter	Liquid (Flare)	ø9.52		ø9.52	
	Gas (Flare)	ø15.88		ø19.05	
	Drain	ø25 (I.D.) ; ø32 (O.D.)			

AB\*: ABY(FUJITSU), ABH(GENERAL)

Note : Specifications are based on the following conditions.

Cooling : Indoor temperature of 27°CDB / 19°CWB, and outdoor temperature of 35°CDB / 24°CWB.

Heating : Indoor temperature of 20°CDB / (15°CWB), and outdoor temperature of 7°CDB / 6°CWB.

Pipe length : 7.5 m; Height difference between outdoor unit and indoor unit : 0 m.

Voltage : 230 [V].

## Dimensions (Unit : mm)

Models: AB\*A30 / AB\*A36 / AB\*A45 / AB\*A54

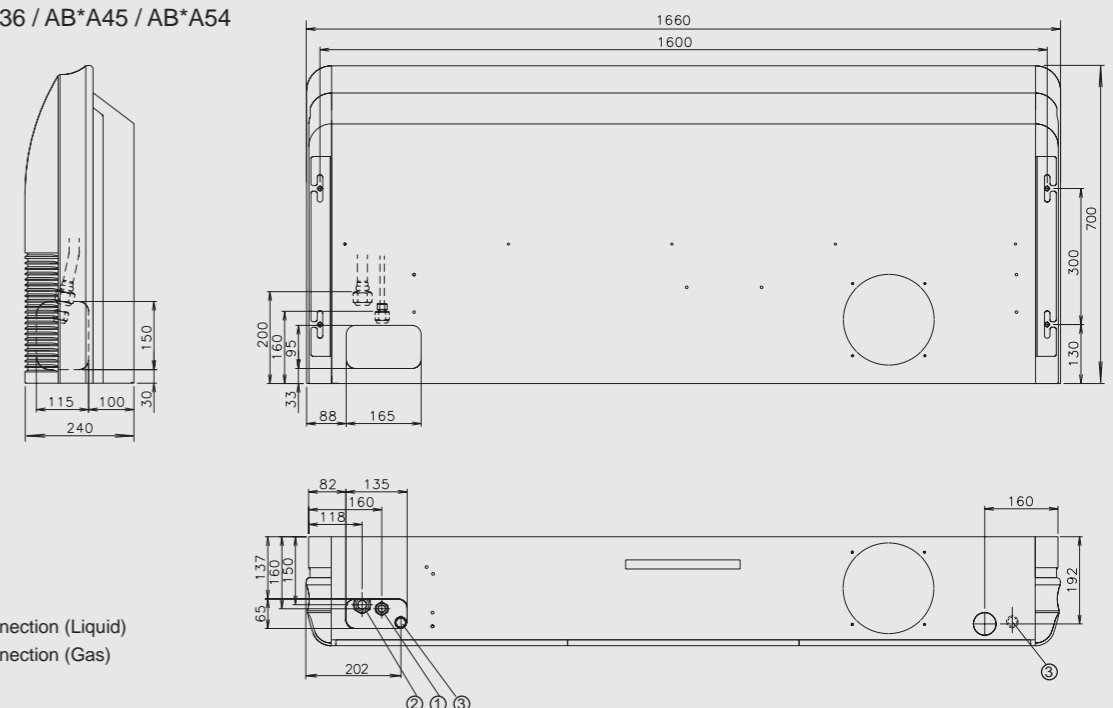

- ① Refrigerant piping flare connection (Liquid)
- ② Refrigerant piping flare connection (Gas)
- ③ Drain piping connection



# Wall Mounted

- |                             |                             |
|-----------------------------|-----------------------------|
| Models (EEV internal model) | Models (EEV external model) |
| <b>AS*A07GACH</b>           | <b>AS*E07GACH</b>           |
| <b>AS*A09GACH</b>           | <b>AS*E09GACH</b>           |
| <b>AS*A12GACH</b>           | <b>AS*E12GACH</b>           |
| <b>AS*A14GACH</b>           | <b>AS*E14GACH</b>           |



Compact and Stylish design indoor

## Filter features

High quality air conditioning by incorporation of high performance filter.

### Long-life\* Ion Deodorization Filter

The filter deodorizes by powerfully decomposing absorbed odors using the oxidizing and reducing effects of ions generated by the ultra-fine-particle ceramic.

(\*The filter can be used for approx. 3 years if it is washed under water to restore its surface action when it is dirty.)

### Apple-catechin Filter

Fine dust, invisible mold spores, and harmful microorganisms are absorbed onto the filter by static electricity, and further growth is inhibited and deactivated by the polyphenol extracted from apples.

## Deodorizing effect (Odor reduction rate)

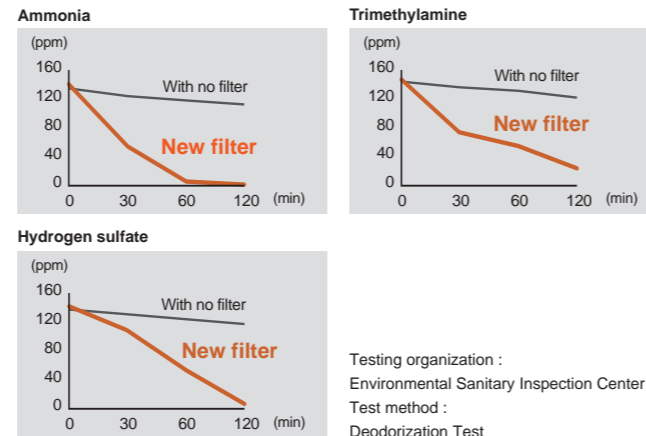

## Compact size

Powerful output even compact design

Width  
**790mm**

Though the indoor unit is compact, it features a large, high pressure cross fan (90mm diameter) in a centre mounted configuration and a Lambda type heat exchanger to provide plenty of power.

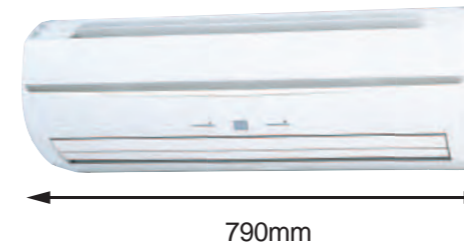

## Auto swing louvre

The Auto Swing Louvre function ensures that the air direction corresponds to the mode selected.

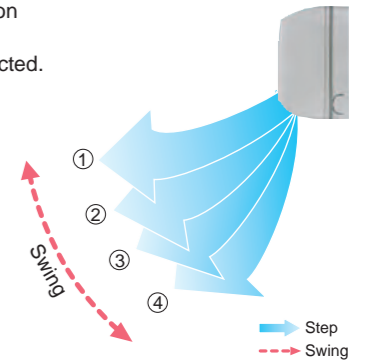

## New style high power DC fan motor

- High power
- Wide rotation range
- High efficiency
- Compact size

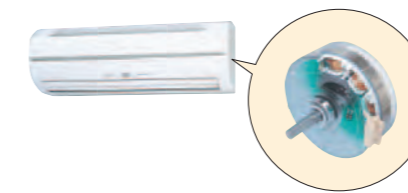

## Easy maintenance

Easy maintenance has been realized as the front panel can be removed for easy access.

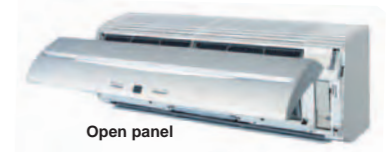

## Symmetrical design

Symmetrical, clean design that suits all interiors.

## Specifications

Model name	AS*A07GACH	AS*A09GACH	AS*A12GACH	AS*A14GACH	AS*E07GACH	AS*E09GACH	AS*E12GACH	AS*E14GACH	
Power source	230V ~, 50Hz				230V ~, 50Hz				
Capacity	Cooling	2.2	2.8	3.6	4.5	2.2	2.8	3.6	4.5
	Heating	2.8	3.2	4.1	5.0	2.8	3.2	4.1	5.0
Input power	W	17	18	22	34	15	16	21	34
Airflow rate	High	490	500	560	670	490	500	560	680
	Med	450	450	480	490	450	450	480	490
	Low	370/420*1	370/420*1	420	420	370/420*1	370/420*1	420	420
Sound pressure level	High	35	36	39	44	34	35	38	43
	Med	33	33	35	37	32	32	34	35
	Low	27/31*1	27/31*1	31	32	26/30*1	26/30*1	30	30
Dimensions (H x W x D)	mm	275 x 790 x 215				275 x 790 x 215			
Weight	kg	9				9			
Connection pipe diameter	Liquid (Flare)	ø6.35				ø6.35			
	Gas (Flare)	ø12.70				ø12.70			
	Drain	ø13.8(I.D.) ; ø15.8-ø16.7(O.D.)				ø13.8(I.D.) ; ø15.8-ø16.7(O.D.)			
EV Kit (option)		—				UTR-EV09XB		UTR-EV14XB	

AS\*: ASY(FUJITSU), ASH(GENERAL)  
Note : Specifications are based on the following conditions.

Cooling : Indoor temperature of 27°CDB / 19°CWB, and outdoor temperature of 35°CDB / 24°CWB.  
Heating : Indoor temperature of 20°CDB / (15°CWB), and outdoor temperature of 7°CDB / 6°CWB.  
Pipe length : 7.5 m; Height difference between outdoor unit and indoor unit : 0 m.  
Voltage : 230 [V].  
\*1 : This value is under cooling operation.

## Dimensions (Unit : mm)

Models: AS\*A07 / AS\*A09 / AS\*A12 / AS\*A14  
AS\*E07 / AS\*E09 / AS\*E12 / AS\*E14

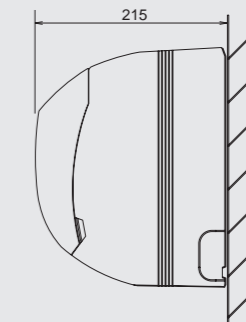
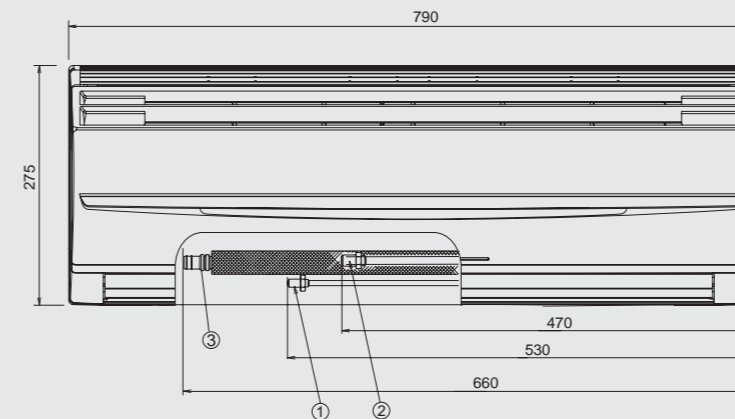

- ① Refrigerant pipe flare connection (Liquid)
- ② Refrigerant pipe flare connection (Gas)
- ③ Drain piping connection

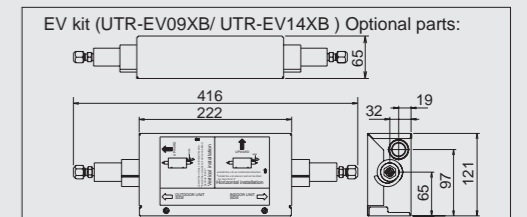

# Wall Mounted

Models

**AS\*A18GACH**

**AS\*A24GACH**

**AS\*A30GACH**

Simple & Elegant Appearance Design



## Compact & Slim design

By using DC fan motor, compact design is realized.

New model



DC fan motor



Previous model

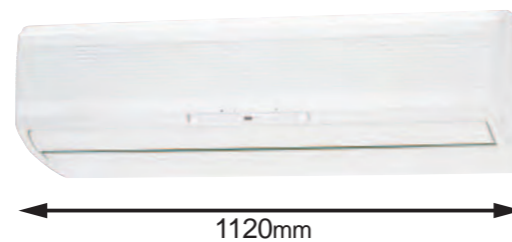

1120mm

## “Vertical airflow” provides powerful floor level heating

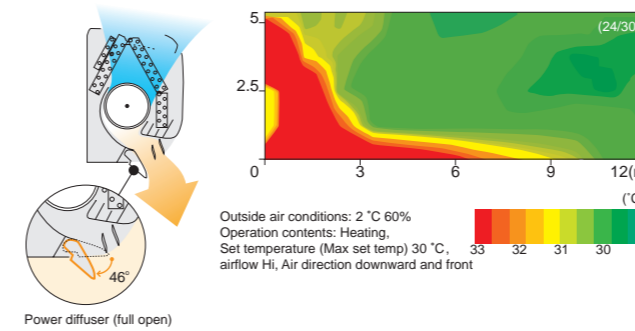

Power diffuser (full open)

## “Horizontal airflow” does not blow cool air directly at the occupants in the room

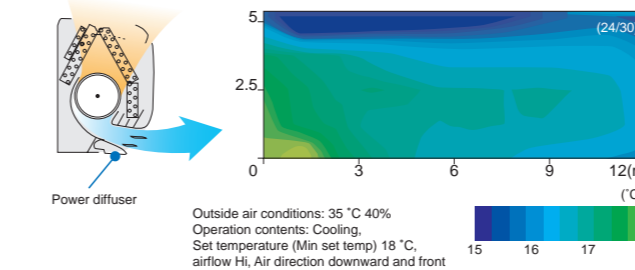

Power diffuser

## Easy maintenance

Simplification of drain pan cleaning improves maintenance-ability.

## Air conditioner filter features

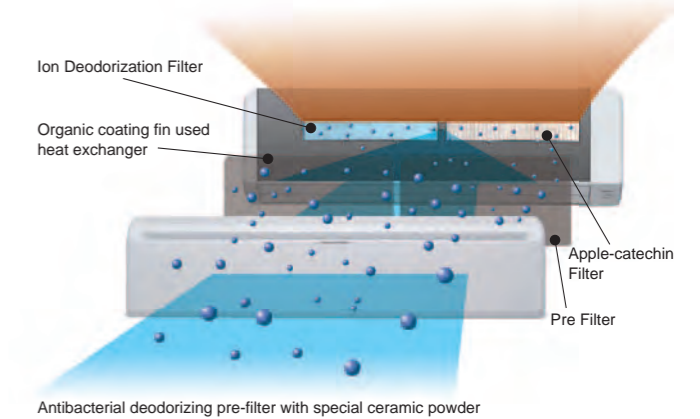

Antibacterial deodorizing pre-filter with special ceramic powder

### Long-life\* Ion Deodorization Filter

The filter deodorizes by powerfully decomposing absorbed odors using the oxidizing and reducing effects of ions generated by the ultra-fine-particle ceramic.

(\*The filter can be used for approx. 3 years if it is washed under water to restore its surface action when it is dirty.)

+ Using different filters at both sides

### Apple-catechin Filter

Fine dust, invisible mold spores, and harmful microorganisms are absorbed onto the filter by static electricity, and further growth is inhibited and deactivated by the polyphenol extracted from apples.

## Specifications

Model name		AS*A18GACH	AS*A24GACH	AS*A30GACH
Power source		230V ~, 50Hz		
Capacity	Cooling	5.6	7.1	8.0
	Heating	6.3	8.0	9.0
Input power		32	60	91
Airflow rate	High	840	1,100	1,240
	Med	770	910	980
	Low	690	730	770
Sound pressure level	High	41	48	52
	Med	39	43	45
	Low	35	35	35
Dimensions (H x W x D)		mm 320 x 998 x 228		
Weight		kg 15		
Connection pipe diameter	Liquid (Flare)	ø9.52		
	Gas (Flare)	ø15.88		
	Drain	ø12 (I.D.) ; ø16 (O.D.)		

AS\*: ASY(FUJITSU), ASH(GENERAL)

Note : Specifications are based on the following conditions.

Cooling : Indoor temperature of 27°CDB / 19°CWB, and outdoor temperature of 35°CDB / 24°CWB.

Heating : Indoor temperature of 20°CDB / 15°CWB, and outdoor temperature of 7°CDB / 6°CWB.

Pipe length : 7.5 m; Height difference between outdoor unit and indoor unit : 0 m.

Voltage : 230 [V].

## Dimensions (Unit : mm)

Models: AS\*A18 / AS\*A24 / AS\*A30

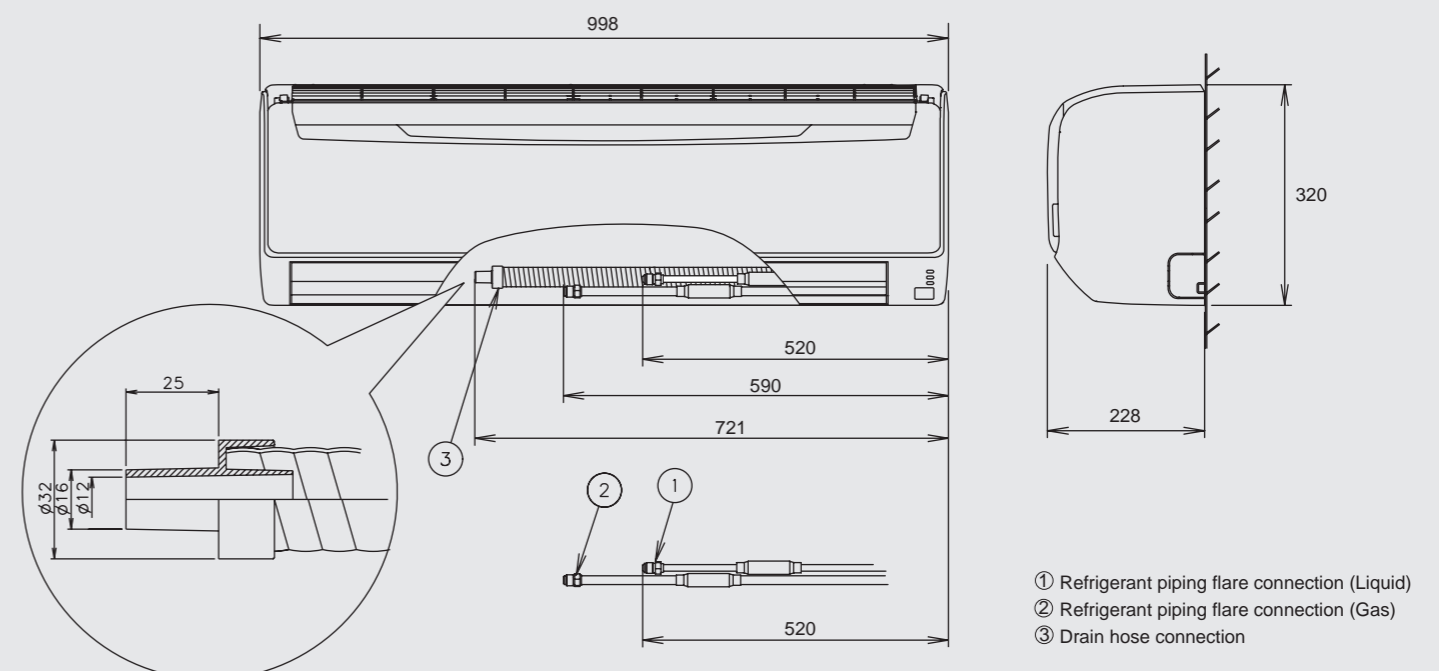

# Control System

Every user's needs are supported by offering a variety of controls, such as individual control, central control and building management control options.

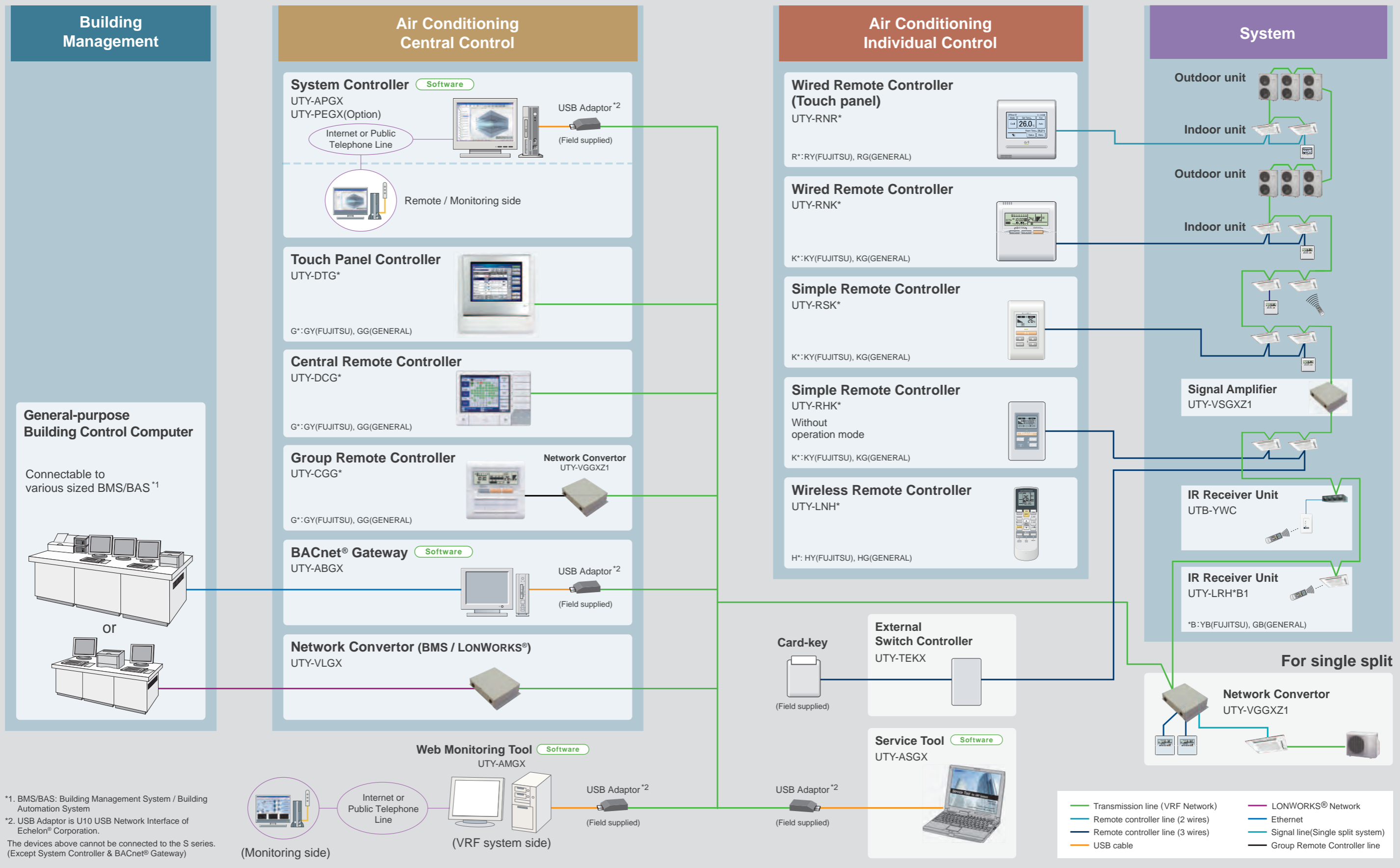

\*1. BMS/BAS: Building Management System / Building Automation System  
 \*2. USB Adaptor is U10 USB Network Interface of Echelon® Corporation.  
 The devices above cannot be connected to the S series. (Except System Controller & BACnet® Gateway)

# Wiring system

- Wiring construction of the control system is made of power source wiring, transmission wiring and remote controller wiring.
- Total wiring length (total length of transmission line) can be extended up to 3,600m (by using signal amplifiers).

Max. transmission line length  
**3,600m**

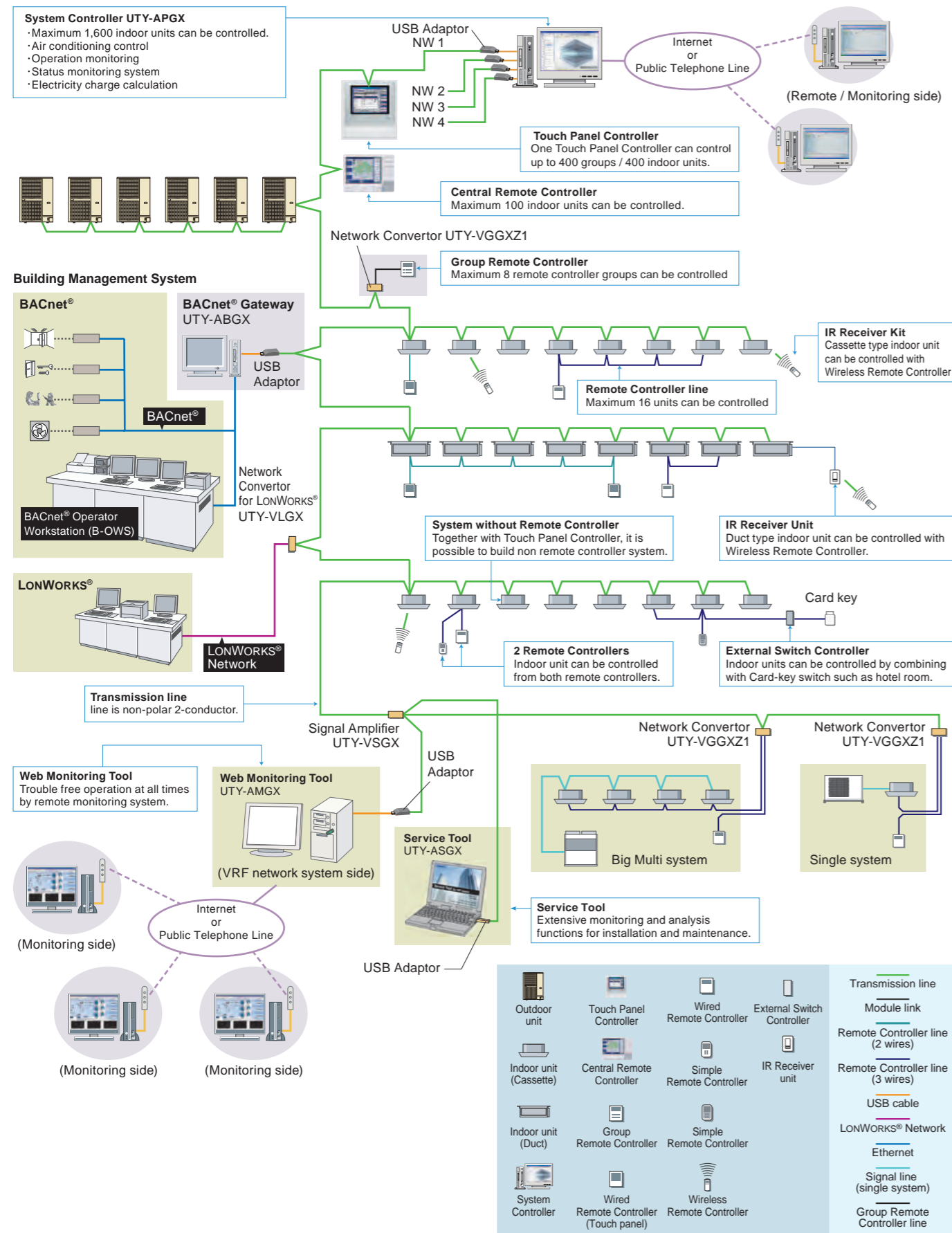

# Comparison table of Controllers

Item	Wired Remote Controller (Touch panel)	Wired Remote Controller	Simple Remote Controller	Simple Remote <sup>*1</sup> Controller	Wireless Remote Controller	Group Remote Controller	Central Remote Controller	Touch Panel Controller	System Controller (Software)		
Model name	UTY-RNRY UTY-RNRG	UTY-RNKY UTY-RNKG	UTY-RSKY UTY-RSKG	UTY-RHKY UTY-RHKG	UTY-LNHY UTY-LNHG	UTY-CGGY UTY-CGGG	UTY-DCGY UTY-DCGG	UTY-DTGY UTY-DTGG	UTY-APGX		
Max. controllable remote controller groups	1	1	1	1	1	8	100	400	1600		
Max. controllable indoor units	16	16	16	16	16	18	100	400	1600		
Max. controllable groups	-	-	-	-	-	-	16	400	1600		
Air conditioning control function	On / Off	●	●	●	●	●	●	●	●		
	Operation mode setting	●	●	●	-	●	●	●	●		
	Fan speed setting	●	●	●	●	●	●	●	●		
	Room temp. setting	●	●	●	●	●	●	●	●		
	Room temp. set point limitation	●	-	-	-	-	●	●	●		
	Test operation	●	●	●	-	●	-	●	-		
	Up/down air direction flap setting	●	●	-	-	●	-	●	●		
	Right/left air direction flap setting	●	●	-	-	●	-	●	●		
	Group setting	-	-	-	-	-	-	●	●		
	RC prohibition	-	-	-	-	-	-	●	●		
	Anti freeze setting	●	-	-	-	-	-	●	●		
	Setback cool/heat	○	-	-	-	-	-	-	-		
Economy mode setting	●	●	-	-	●	-	●	●			
Display	Failure	●	●	●	-	●	●	●	●		
	Defrosting	●	●	●	●	-	-	●	●		
	Current time	●	●	-	-	●	●	●	●		
	Day of week	●	●	-	-	-	-	●	●		
	R.C. prohibition	●	●	●	●	-	●	●	●		
	Cooling/heating priority	●	●	●	●	-	●	●	●		
	Address display	●	●	●	●	-	●	●	●		
	Room temp	●	-	-	-	-	-	-	-		
	Multi language	●	-	-	-	-	-	●	●		
	Summer time	●	-	-	-	-	-	●	●		
	Name registration	●	-	-	-	-	-	●	●		
	Backlight	●	-	●	●	-	-	●	-		
Timer	Schedule timer	Period	Week	Week	-	-	-	Week	Week	Year	Year
		On/Off, Temp, mode, times per day	8	4	-	-	-	4	20	20	144
	On/off timer	●	●	-	-	●	-	-	-	-	
	Sleep timer	-	-	-	-	●	-	-	-	-	
	Program timer	-	-	-	-	●	-	-	-	-	
	Auto off timer	●	-	-	-	-	-	-	-	-	
	Day off	●	●	-	-	-	-	●	●	●	
	Min. unit of timer setting (Minutes)	10・30	30	-	-	5	10	10	10	10	
	Control	Status monitoring system	-	-	-	-	-	●	●	●	
		Electricity charge calculation	-	-	-	-	-	-	-	●	
		Error history	●	●	●	●	-	●	●	●	
		Emergency stop	-	-	-	-	-	-	● <sup>*2</sup>	● <sup>*2</sup>	-
Control via internet		-	-	-	-	-	-	-	-	●	
E-mail notification for malfunction		-	-	-	-	-	-	-	-	●	
Key lock	Child lock	●	-	-	-	-	●	●	●		
	Child lock	●	-	-	-	-	●	●	●		

\*1 "Operation mode" setting is not available for this model.  
 \*2 This function is available only through external input. control.

● : Supported  
 ○ : Supported soon  
 - : Not supported yet

# Wired Remote Controller (Touch Panel)

UTY-RNR\*

Max. controllable  
**16**  
indoor units

Easy operation by high-definition large STN-LCD touch panel screen

- Easy finger touch operation with LCD panel
- Built-in weekly/Daily timer(ON/OFF,Temp.,Mode)
- Backlight enables easy operation in a darkened room
- Room temperature display
- Control up to 16 indoor units
- Corresponds to 7 different languages (English, Chinese, French, German, Spanish, Russian, Polish)

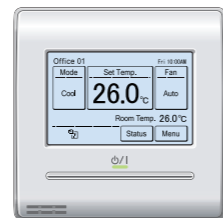

## Functions

### High performance and compact size

- In addition to the individual control, various energy saving controls can be realized using one remote controller only.



### Accurate and comfortable control

- Indoor temperature can be detected accurately by the inclusion of a thermo sensor in the body of the wired controller.

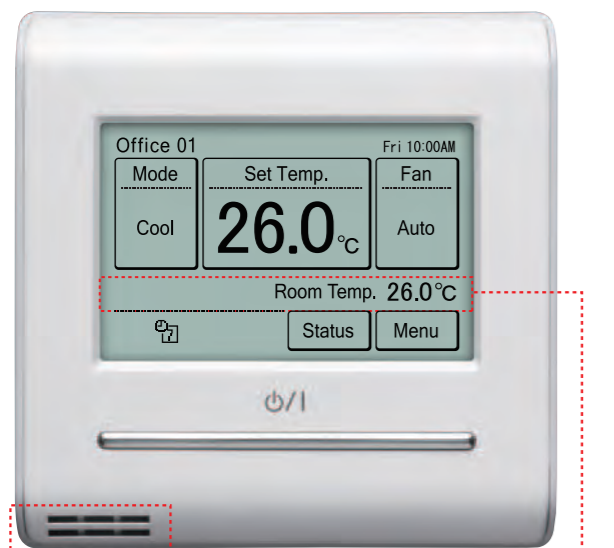

Room temperature sensor

Room temperature display

### Backlight

- Backlight enable easy operation in a darkened room.
- For the lighting time of Backlight, 30 or 60 seconds can be set.
- Backlight activates while the buttons are operated and goes off 30 or 60 seconds after the operation stops.

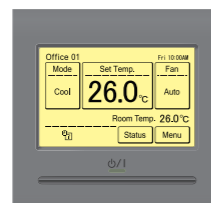

### Various energy saving control

#### Auto OFF Timer

- The indoor unit automatically turns off after a set time has passed.
- The time interval for which auto off works can be set.

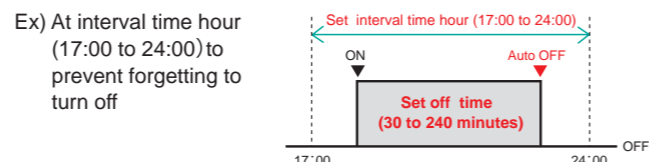

#### 2 schedules Weekly Timer

- 2 schedules such as for the summer and winter can be set.
- 8 setting changeable per day of week (Setting items: On/Off, Temperature, Mode, Time)

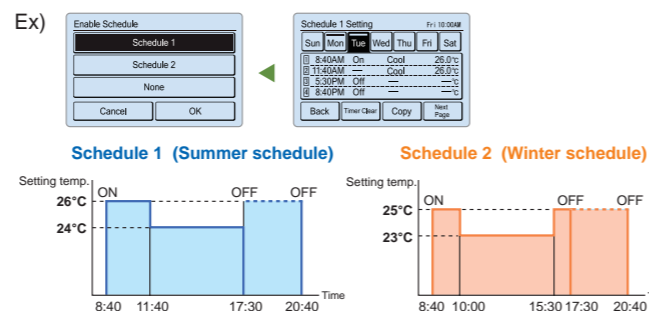

#### Set Temperature Auto Return

- The setting temperature automatically returns to the previous setting temperature.
- The time range in which the set temperature can be changed is 10 to 120 minutes.

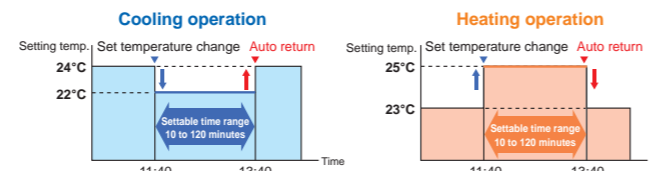

#### Set Temperature Upper and Lower Limit Setting

- The set temperature range can be set for each operation mode. (Cooling / Heating / Auto)

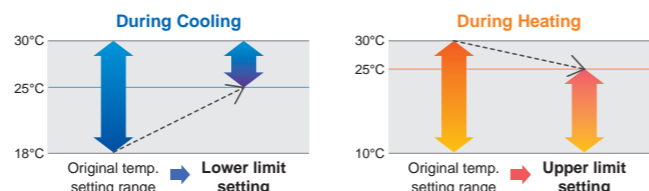

## Various convenient functions

### Setback-Cool / Setback-Heat (Future release)

- Cooling / Heating is automatically started when the room temperature reaches a setting temperature even if the indoor unit is off.

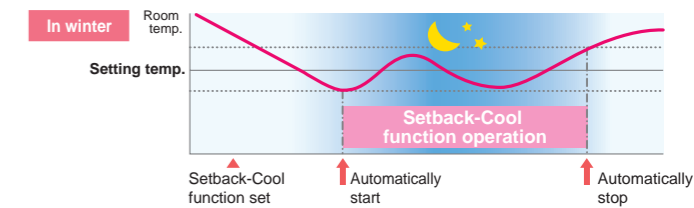
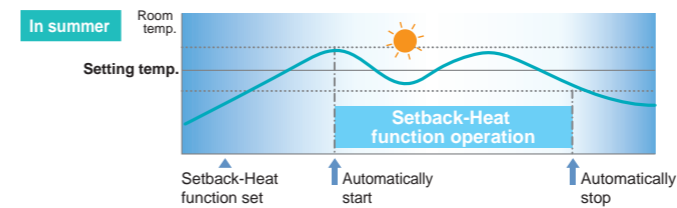

### Displays setting status and Limitations

- The remote controller settings can be easily checked

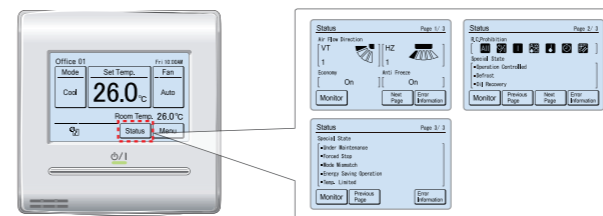

### Summer Time display

- This function can be set easily from Menu screen

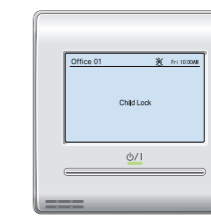
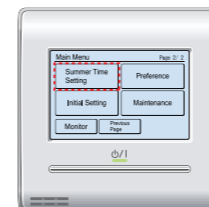

### Child lock

- Lock / unlock method: Push the ON/OFF button and the screen (4 seconds)

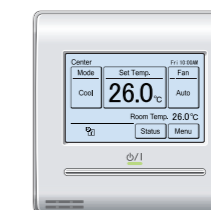

### Name Registration

- Indoor unit names can be registered in the remote controller screen. This makes it easy to identify the indoor unit you want to control in the room.

## Simplified installation

### Uses non-polar 2-wire type

- The faulty wiring can be prevented by using non-polar 2-wire.

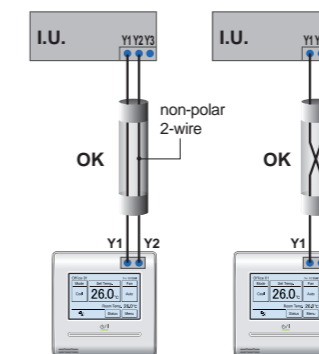

### Auto Address Setting/Setting Position Notification

- Reduce errors and install time compared with the current specification Rotary SW
- When will be set remote controller groups, can also be set automatically new Wired remote controller address
- After auto address setting of new wired remote controller groups, what number can also confirm addresses

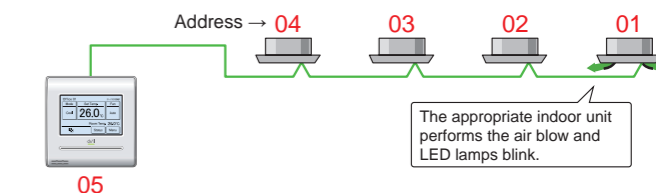

## Easy Maintenance

### Error History Display

- The errors that occur in the indoor unit or remote controller are saved as a history.
- A maximum of 32 error incidents can be saved.



## Specifications

Model name	UTY-RNR*
Power Supply	DC 12V
Dimensions (H x W x D) (mm)	120 x 120 x 20.4
Weight (g)	220

DC12V is supplied by the indoor unit. R\* : RY(FUJITSU), RG(GENERAL)

# Wired Remote Controller

UTY-RNK\*

Max. controllable  
**16**  
indoor units

The room temperature can be controlled by detecting the temperature accurately from the built-in sensor

- Simple operation with Built-in Weekly / Daily Timer.
- Control up to 16 indoor units.
- Up to 2 wired remote controllers can be connected to a single indoor unit.

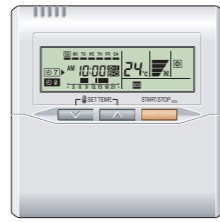

## Functions

### Powerful features and compact size

This Wired Remote Controller incorporates four primary functions into a single unit.



### Accurate and comfortable

Indoor temperature can be detected accurately by the inclusion of a thermo sensor in the body of the wired controller.

This new wired remote controller and the optional remote sensor allows flexibility in sensor location, suitable for all requirements.

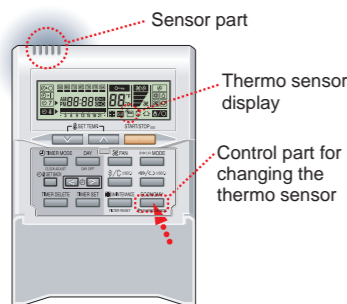

### Example of changing sensor

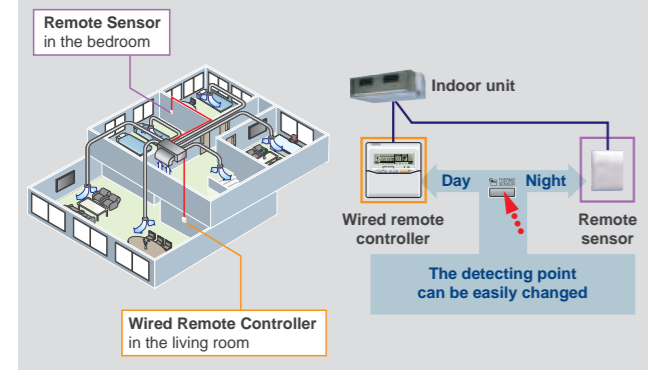

Displayed temperature is set temperature.

### Built-in timers

Easy-to-understand time bar display

**Weekly timer** : Possible to set ON/OFF time to operate twice each day of the week.

**Setup screen example**  
Set to Wednesday: 8:00 to 20:00.

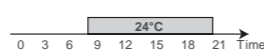

Screen after setup



**Setback timer** : Possible to set temperature for two times spans and for each day of the week.

**Setup screen example**  
Set from Sunday to Saturday: 12:00 to 15:00, 28°C.

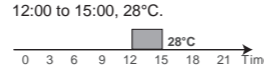

At "Weekly timer" + "Set back timer" setup



### Diagnosis check function

Two methods are available for determining the cause of failure in the event of a malfunction occurs:

- Malfunction diagnosis function
- Error history (Last 16 error codes can be accessed)

### Simple installation

Components are compatible with standard switch boxes. Flat back surface allows to be installed wherever it is needed.

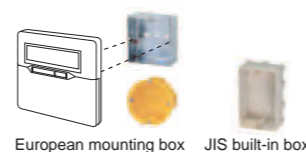

# Simple Remote Controller

UTY-RSK\*

UTY-RHK\* (Without Operation mode)

Max. controllable  
**16**  
indoor units

Compact remote controller provides access to basic functions

- Up to 16 indoor units can be controlled with one remote controller.
- Suitable for hotels or offices as it is easily operated with no complex functions.



UTY-RSK\*



UTY-RHK\*  
Without Operation mode

## Functions

### User-friendly operation

- Provides access to basic operations, such as Start / Stop, Fan control, Operation mode switching, and Room temperature setting.
- A large On / Off button is provided in the centre of the remote controller for easy operation.
- Can be used jointly with other individual control unit.
- Following an error display, diagnostics can be carried out on the controller.

### Simple installation

Can be mounted on the European Mounting Box (Installation dimension: 60mm) or the JIS Built-in Box (Installation dimension: 83.5mm).



### Backlight

- Backlight enables easy operation in a darkened room.
- Backlight activates during all button operations, and lasts 10 seconds in Operation mode and 5 seconds in stop mode after a button is pressed.



### Functions summary

Model	UTY-RSK*	UTY-RHK*
Operation	●	●
On / Off	●	●
Fan control	●	●
Operation mode	●	—*1
Room temp. setting	●	●

\*1: "Operation mode" setting is not available. It is recommend to use together with other type controller.

## Specifications

Model name	UTY-RNK*
Power Supply	DC 12V
Dimensions (H x W x D) (mm)	120 x 120 x 18
Weight (g)	160

DC12V is supplied by the indoor unit. K\* : KY(FUJITSU), KG(GENERAL)

## Specifications

Model name	UTY-RSK*	UTY-RHK*
Power Supply	DC 12V	
Dimensions (H x W x D) (mm)	120 x 75 x 14	
Weight (g)	90	90

DC12V is supplied by the indoor unit. K\* : KY(FUJITSU), KG(GENERAL)

# Wireless Remote Controller

UTY-LNH\*

Simple and sophisticated operations with a choice of 4 daily timers

- A single controller controls up to 16 indoor units.



Max. controllable  
**16**  
indoor units

Selectable  
**4**  
daily timers

## Functions

### Built-in daily timer

Select from 4 different timer programs :

On / Off / Program / Sleep

**Program timer :** The program timer operates the ON and OFF timer once within a 24 hour period.

**Sleep timer :** The sleep timer function automatically corrects the set temperature according to the time setting to prevent excessive cooling or heating during sleep hours.

### Cooling operation/dry operation

When the sleep timer is set, the set temperature automatically rises 1°C every hour. The set temperature can rise up to a maximum of 2°C.

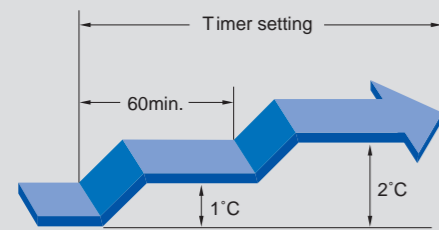

### Heating operation

When the sleep timer is set, the set temperature automatically drops 1°C every 30 minutes. The set temperature can drop to a max. of 4°C.

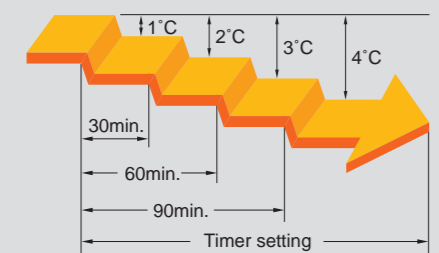

## Specifications

Model name	UTY-LNH*
Battery	1.5V (R03 / LR03 / AAA) x 2
Dimensions (H x W x D) (mm)	170 x 56 x 19
Weight (g)	85

H\* : HY(FUJITSU), HG(GENERAL)

## Easy installation and operation

Code selector switch prevents indoor unit mix-up. (Up to 4 codes can be set.)

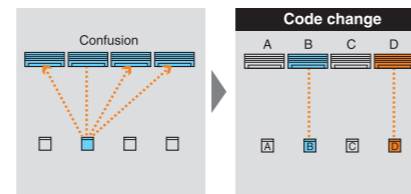

Wide and precise

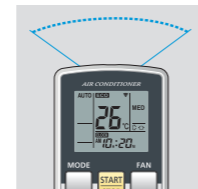

## Address setting

During installation work, address setting can be performed using the Wireless Remote Controller, thus eliminating manual switch setting.

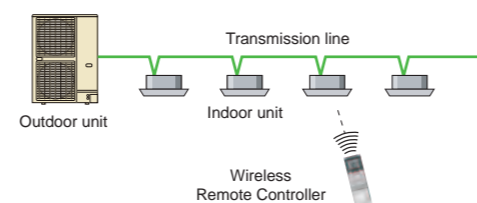

# IR Receiver Unit

UTB-YWC

Necessary to control for all duct type by Wireless Remote Controller



## Wiring connection

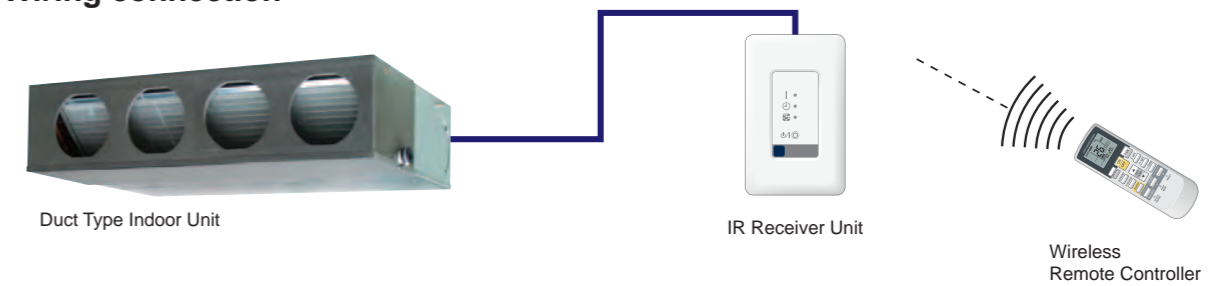

## Specifications

Model name	UTB-YWC
Battery	DC 12V
Dimensions (H x W x D) (mm)	145 x 90 x 30
Weight (g)	150

# IR Receiver Unit

UTY-LRH\*B1

Cassette type indoor unit can be controlled with Wireless Remote Controller



## Specifications

Model name	UTY-LRH*B1
Battery	DC 12V
Dimensions (H x W x D) (mm)	193.9 x 193.9 x 31.2
Weight (g)	140

H\* : YB(FUJITSU), GB(GENERAL)

# Group Remote Controller

UTY-CGG\*

Group control of indoor units with simple operation

- Up to 8 remote controller groups can be controlled by one Group Remote Controller.
- Up to 64 Group Remote Controllers can be connected in one VRF network system.
- Network Converter (UTY-VGGXZ1) is required to connect Group Remote Controllers to a VRF network system.  
(Network Converter allows up to 4 Group Remote Controllers)

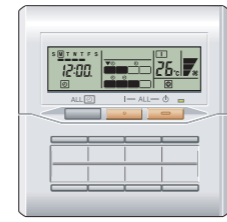

Max. controllable  
**8**  
remote controller groups

Max. connectable  
**64**  
group R.C. in a VRF network system

## Functions

### High performance and compact size

ON / OFF, Operating mode, Room temperature and Fan speed setting can be controlled / monitored centrally or individually.



### Control up to 8 remote controller groups

Single Group Remote Controller controls and monitors up to 8 remote controller groups.

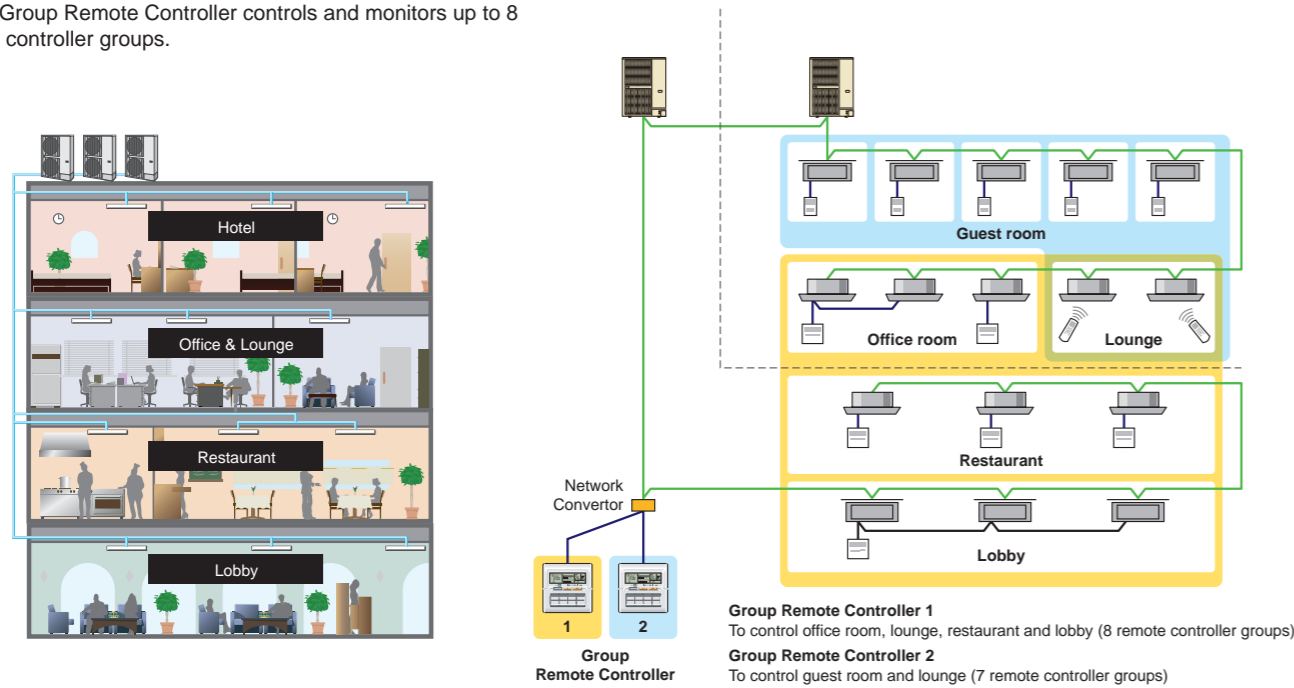

## Useful functions

1 Timer setting at all the connected indoor units is possible by centralized timer on the front panel.

**ALL TIMER Button**  
Press the ALL TIMER button to turn the timer operation on or off for all indoor units.

3 The indoor unit can be quickly turned on and off by ON / OFF button of each indoor unit on the front of the door.

**Indoor Unit Name Labels**  
Write the names of the indoor units on the included labels and attach them.

**ON / OFF Button**  
Press the ON / OFF button to turn the corresponding indoor unit on or off.

**With cover closed**

**Indoor Unit Operation Indicators**  
Timer setting at all the connected indoor units is possible by centralized timer on the front panel.  
■ : On □ : Off  
○ : Timer operation ▼ : Selection

**2 All the connected indoor units can be turned on / off simultaneously by centralized ON/OFF button on the front of the cover.**

**Operation Lamp**  
This is on if any of the indoor units is operating. This flashes if any of the indoor units has malfunction(s).

**ALL OFF Button**  
Press the ALL OFF button to turn off all of the indoor units.

**ALL ON Button**  
Press the ALL ON button to turn on all of the indoor units.

**Timer and Clock Display and setting**

- Setting Display
- Day Display
- Timer and Clock Display
- Timer Mode Display
- Timer Mode (DELETE) Button
- DAY Button
- Set Time Button
- PROGRAM (CLOCK ADJUST) Button
- ENTER Button

**With cover open**

**Displaying the Status and Controlling indoor units**

- Transmission Display
- Operation Lock Display
- ON / OFF Display
- Fan Speed Display
- Set Temperature Display
- Operation Mode Display
- ON / OFF Button
- Select Button
- Fan Control Button
- Master Control Button \*1, \*2, \*3
- Set Temperature Button
- Child Lock Function

\*1 : "AUTO (A)" is not available for a heat pump model unless it is set up for the master indoor unit.  
\*2 : "FAN (FAN)" is not available for a heat pump model  
\*3 : "HEAT (HEAT)" is not available for a cooling only model

## Built-in weekly timers

The weekly timer is provided as a standard function.

1. The timer can be set up for up to 4 times per day. (On / Off, operating mode, set temperature)
2. Allows separate settings for each day of the week.

**ON / OFF switching**

Air conditioning ON/OFF setting corresponding to air conditioning specification needs is possible.

**Cooling / Heating switching**

Switching between the cooling mode and heating mode can be set by time.

**Temperature switching (Peak power cut)**

Since peak power cut is performed in a planned way, setting which changes the room temperature linked with time is possible.

**Temperature switching (Anti-freeze)**

Low temperature heating operation can be set to prevent freezing in cold regions at night, etc.

**Stop setting**

Indoor unit stop setting at operation end time is possible.

## Specifications

Model name	UTY-CGG*
Power Supply	DC 12V
Dimensions (H x W x D) (mm)	120 x 120 x 18
Weight (g)	200

DC12V is supplied by a network converter. G\* : GY(FUJITSU), GG(GENERAL)



# Central Remote Controller

## UTY-DCG\*

Central control of small- and medium-sized buildings and tenants. The operation status of all connected indoor units can be viewed at a glance on a large LCD monitor to simplify individual control to batched control.

- Individual control and monitor of 100 indoor units
- 5 inch TFT color screen
- User friendly view and easy operation
- External input / output contact
- Detachable power supply unit
- Corresponds to 7 different languages (English, Chinese, French, German, Spanish, Russian, Polish)



Max. controllable  
**100**  
Indoor units

Max. controllable  
**16**  
groups

### User friendly operation

Operation status monitor displays for all indoor units  
Easy comprehensible display and operation button

**Function Menu**  
Function menu displays the items to select.

**Function button**  
1 to 1 function button supports easy setting.

### System overview

- It allows multiple indoor units grouping (Max.16 groups controlled)
- Interlock with external device

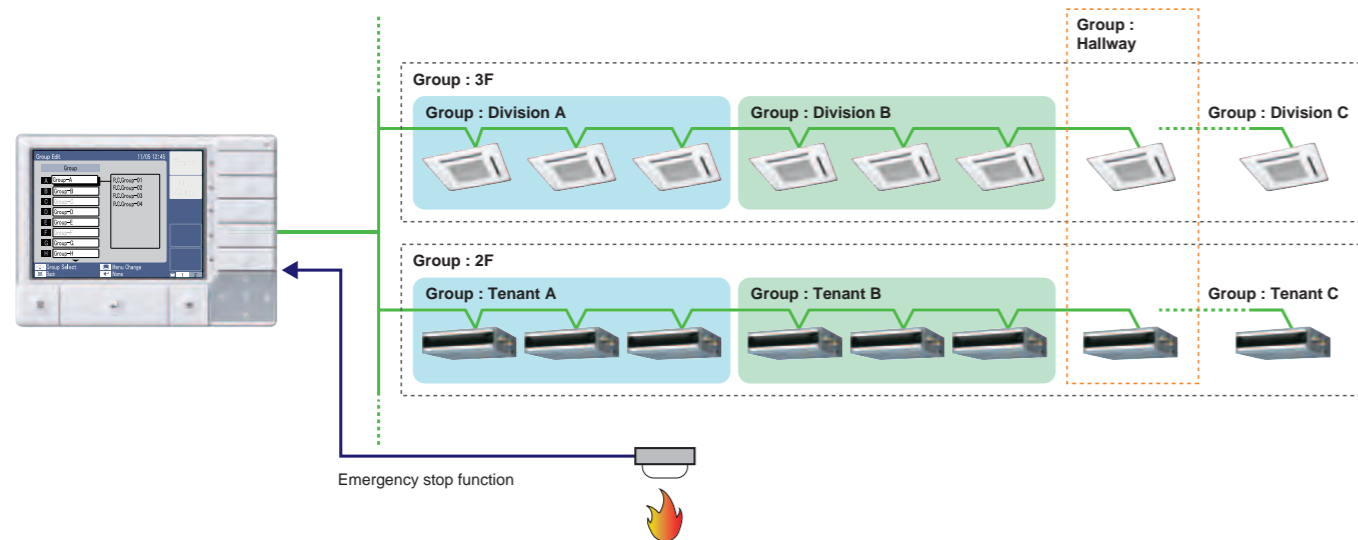

### Functions

#### Diverse control of indoor units

- Individual control (On / Off, Mode, set Temp, Fan speed, Economy operation, Antifreeze operation)

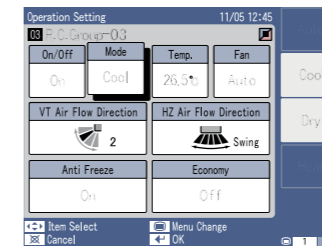

- Remote controller prohibition (All, On / Off, Mode, Temp, Timer, Filter) : R.C prohibition setting prohibits individual remote control operation from this controller

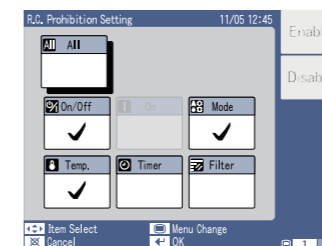

- Room temperature set point upper and lower limitation

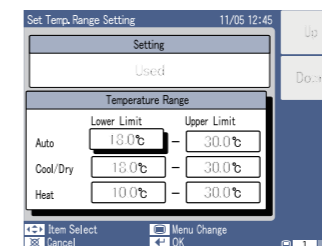

- Weekly timer : Weekly timer can set the timer by various combinations.

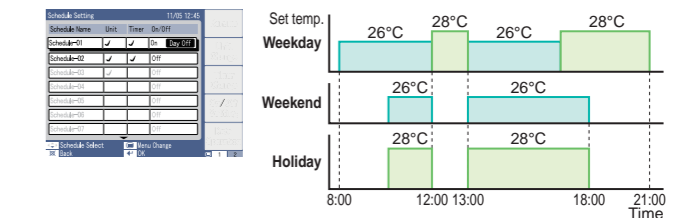

- Automatic clock adjustment : The time setting of each controller can be set in batch automatically.

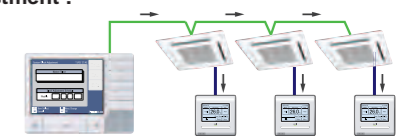

#### Error history

- Max 200 Errors memorize.
- Suitable maintenance is possible by analysis of the error history data.

No.	Date Time	Name	Address	Error Code
001	2009.09.01 13:00	R.C.Group-01	01-00-00	14
002	2009.09.01 13:00	R.C.Group-01	01-00-00	14
003	2009.09.01 13:00	R.C.Group-01	01-00-00	14
004	2009.09.01 13:00	R.C.Group-01	01-00-00	14

### Easy Installation

- The control panel and power supply unit can be installed separately.
- For flexibility in installation, the Control panel can be built into the wall or fix on the wall.

#### Setting pattern 1

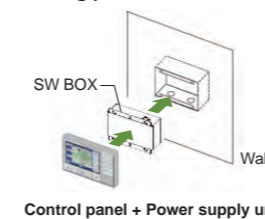

#### Setting pattern 2

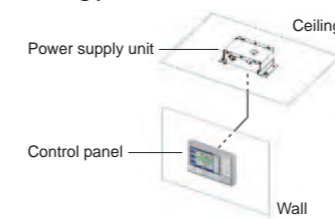

- Automatic or manual indoor unit registration

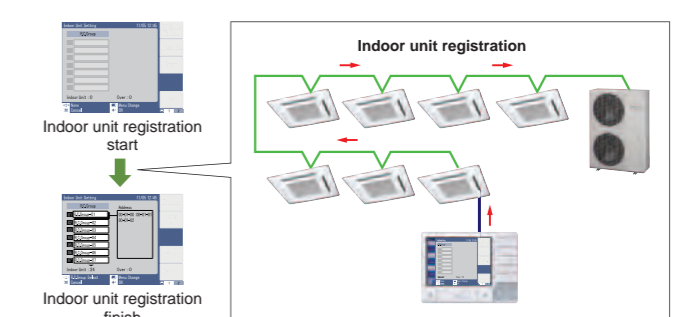

### Specifications

Model name	UTY-DCG*	
	Control Panel	Power Supply Unit
Power Supply	DC 5 V	100-240V, 50-60Hz, Single phase
Dimensions (H x W x D) (mm)	120 x 162 x 25.7	99 x 135 x 39.2
Weight (g)	308	355

#### <PACKING LIST>

Packing List	Control Panel / Power Supply Unit / Connecting cable, etc.
--------------	--

G\* : GY(FUJITSU), GG(GENERAL)

# Touch Panel Controller

UTY-DTG\*

Max. controllable  
**400**  
Indoor units



High visibility and easy operation via high resolution 7.5 inch TFT-LCD touch panel screen

- Large-sized 7.5-inch TFT color
- LCD Easy finger touch operation
- Stylish shape and design to suit all application
- No additional component is required for installation
- Up to 400 indoor units can be controlled
- Selectable 2 display types (Icon / List) in monitoring mode
- Corresponds to 7 different languages, English, Chinese, French, German, Spanish, Russian, Polish.

## Functions

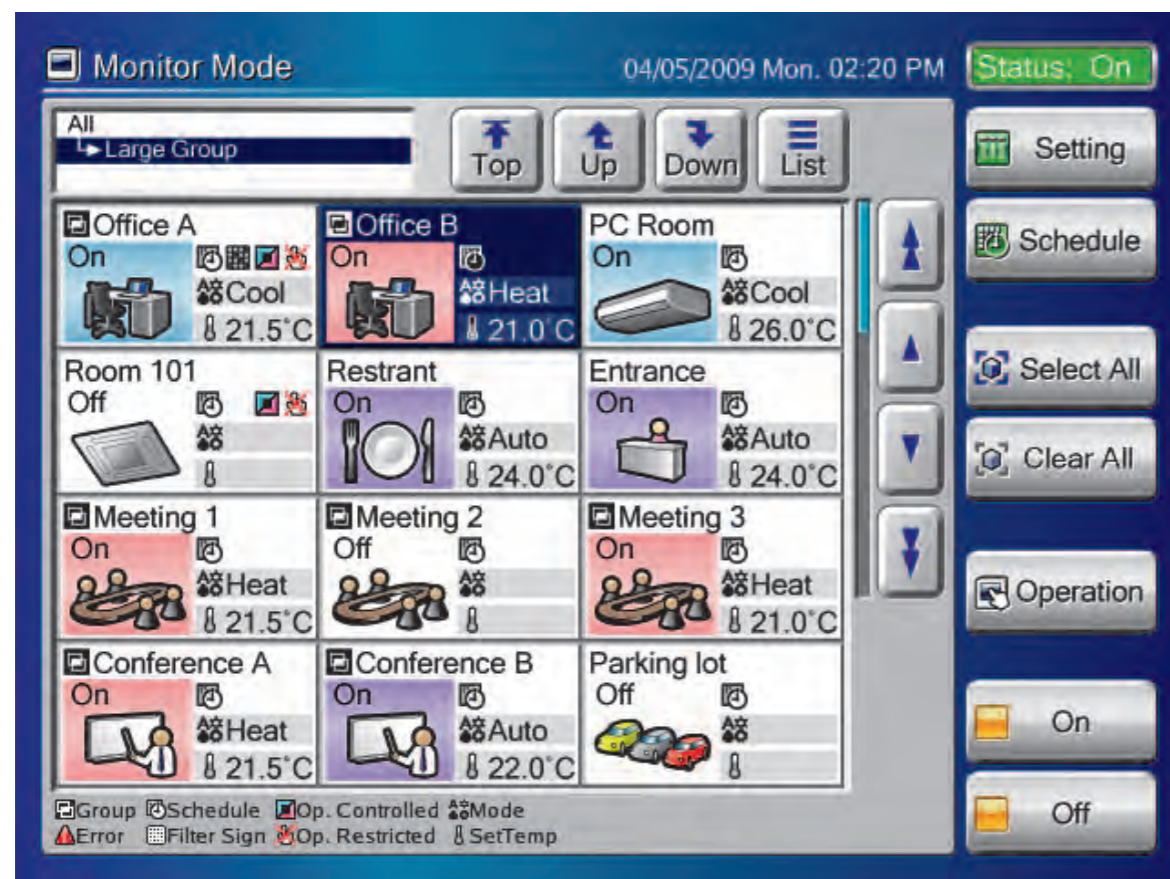

Real size screen image

## Easy operation

- Large and wide-angled LCD is easily viewable even at a distance
- Easy-to-understand icon-driven Graphical User Interface (GUI)
- Wide range of simple-to-understand icons



- Operation can be selected using your finger or the dedicated touch pen by pressing the appropriate on-screen icon
- Up-to-date status display
- Background color identifies current control operation Blue for monitoring, green for operational control

## Easy maintenance

- Flat touch screen is easily cleaned
- Non-glare coating on touch panel controller minimizes fingerprint marking
- Easy-to-remove front cover



## Up to 400 indoor units can be controlled

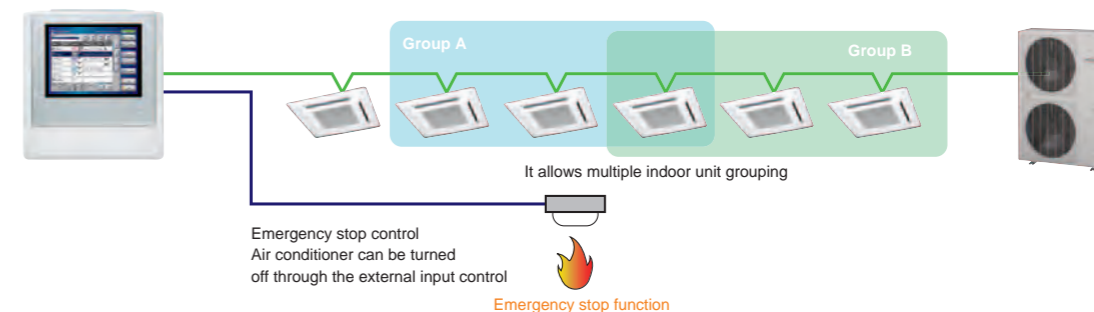

## Function

- Up to 400 indoor units can be controlled
- It allows multiple indoor units grouping
- Schedule timer function is standard (20 patterns per day)
- Emergency stop function(through the external input control)
- Temperature upper and lower limit setting
- The clock of each indoor unit correct setting



Individual control



Flexible grouping



Schedule control



Indoor units operation monitoring

## Automatic clock adjustment

The time setting of each controller can be set in batch automatically.

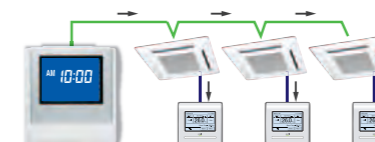

## Versatility

CSV format data edited by PC can be imported to Touch Panel Controller.

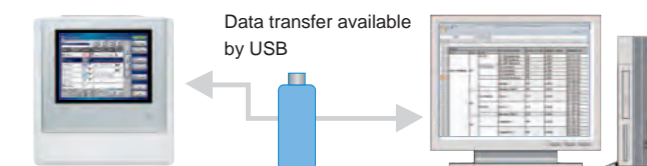

## Easy installation

Touch Panel Controller is easily mounted to the wall Flat back surface allows to be installed wherever it is needed.

- Correctable mechanism for tilting (horizontal) after the installation of the body

No additional component is required for installation

- There is no need for the installation space of power supply adaptor and transmission adaptor etc.



## Specifications

Model name	UTY-DTG*
Power Supply	100-240V 50/60Hz, Single phase
Dimensions (H x W x D) (mm)	260 x 246 x 54
Weight (g)	2,150
Interface	USB 2.0

G\* : GY(FUJITSU), GG(GENERAL)

# System Controller

Software

## UTY-APGX

System Controller realizes the advanced integrated monitoring & control of VRF network system from small scale buildings to large scale buildings.

- Up to a maximum of 4 VRF network systems, 1600 indoor units, and 400 outdoor units can be controlled.
- Supports VRF S series, V series and V-II series.
- In addition to air conditioning precision control function, central remote control, electricity charge calculation, schedule management, and energy saving functions are strengthened and building manager and owner needs are met.



Max. controllable  
**4**  
VRF network systems

Max. controllable  
**400**  
Outdoor units

Max. controllable  
**1,600**  
Indoor units

## Functions

### User friendly view and operation

- **Click & Operate** : The property is shown visually from the perspective most suitable for operation and operated accordingly (Click & Operate). You can select from among the 4 displays of site, building, floor, or list.
- **Freely define groups for batched control** : Indoor units can be freely grouped for simple batched control from a tree menu. Grouping by hierarchal structure, such as by section, division or department is possible.

**Click & Operate the whole building!** Properties can be shown using one of the four displays of site, building, floor, or list.

**Click & Operate any specified unit(s)!** The display is easily changed by pressing the button.

**Batched control of freely defined groups**

**Batched control of freely selected units**

**Click & Operate the whole floor!**

**Click & Operate the unit!**

The floor layout drawing can be imported to easily make the settings for the actual building.

## Energy saving management

With UTY-PEGX Option

### Peak cut operation Option

A power meter is connected to detect the total power consumption while shifting the indoor unit set temperature, set the indoor unit forced thermostat off, and taking other measures to carefully control the power consumed while maintaining comfort and conducting control to maintain the target power consumption set for each time. The indoor units to be controlled can be freely grouped and the control level can be set.

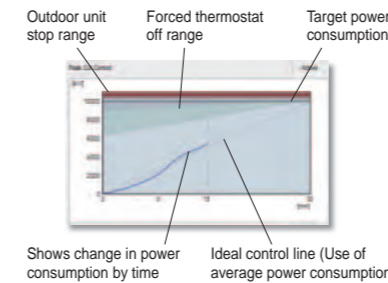

### Outdoor unit capacity save Option

Outdoor unit capacity save switches the outdoor unit capability upper limit to suppress power consumption during hot summers and cold winters by averaging the power saving effect of each refrigerant system. You can select from 50% or more of the capacity upper limit.

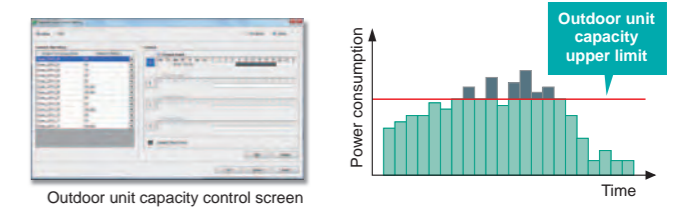

### Indoor unit rotation operation Option

The operation of indoor units can be automatically rotated within a group in accordance with the set annual schedule to reduce power consumption while maintaining comfort. The indoor unit operation stoppage rate can be selected.



### Batched stop

Batched stop at a freely set time for a property, building, or freely set block unit can be done to prevent any air conditioning unit from being forgotten to be turned off at the end of office hours, etc. In addition, any air conditioning unit whose operation is left on can be immediately identified by the icon color for a building or indoor unit in the monitoring screen and batched stop conducted in response.



## Electricity charge apportionment

### Electricity charge apportionment calculation framework

Suppose you want to find the power consumed by the air conditioners of each tenant from the electricity charge for each month. With electricity charge apportionment function, used energy apportionment ratio will be provided, calculating in detail the energy consumed by the units used by each tenant. This information is then used to calculate the charges for the electricity consumed for air conditioning by each tenant from the total electricity charges in the bill from the electric power company. (See figure at right) The detailed calculation takes into consideration such things as unused rooms and nighttime electricity charges and shows them in a charges calculation sheet.

### System Configuration Example

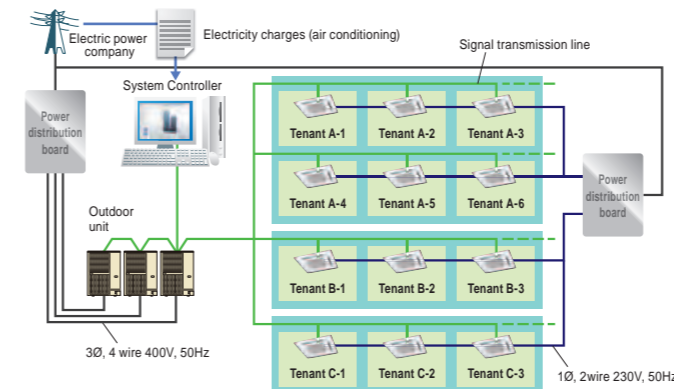

**Energy used by each unit is calculated**

Tenant A, Tenant B, Tenant C

**Energy apportioned by the outdoor unit to each indoor unit is calculated**

Tenant A, Tenant B, Tenant C

**Electricity charges by tenant are calculated**

The distribution ratio for energy used by each indoor unit is calculated and the electricity charges for the energy used by each indoor unit are calculated from the total electricity charges.

Tenant A Electric Bill, Tenant B Electric Bill, Tenant C Electric Bill

**The energy used by each indoor unit and the energy apportioned by the outdoor unit are added together to calculate the total amount of energy used.**

Indoor unit energy used + Apportioned energy = Indoor unit total energy used

### Remote centralized control

System Controller may be used on site or remotely over various networks for remote central control. System Controller requires 2 softwares working together. VRF Controller runs on site and communicate with VRF system. VRF Explorer runs remotely and provides user interface and communicate with the VRF Controller. VRF Controller and VRF Explorer program may run in a single PC or in different PCs separated by network. By using VRF Explorer software, one PC can perform central control of 10 VRF system sites with max. 20 buildings per site.

On site central control  
Max. 4 VRF network systems per site

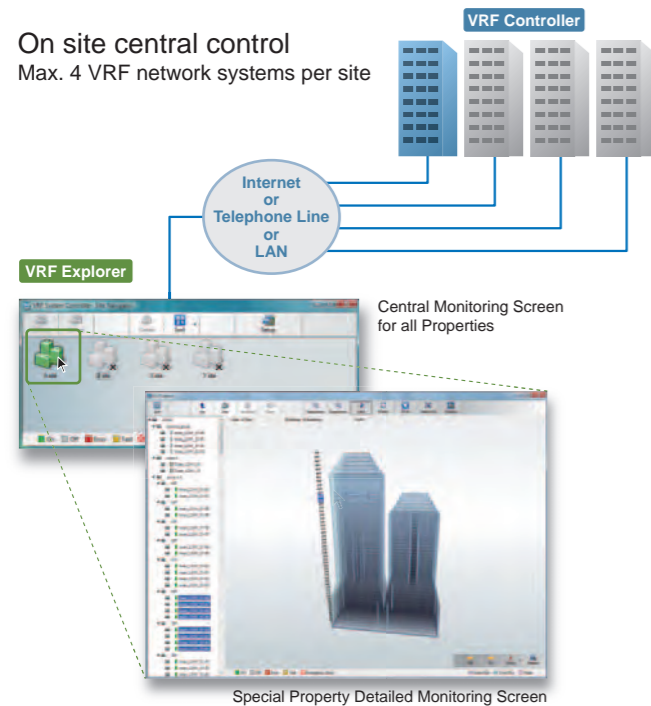

### Remote central control

1 VRF Explorer can control or monitor up to 10 sites.

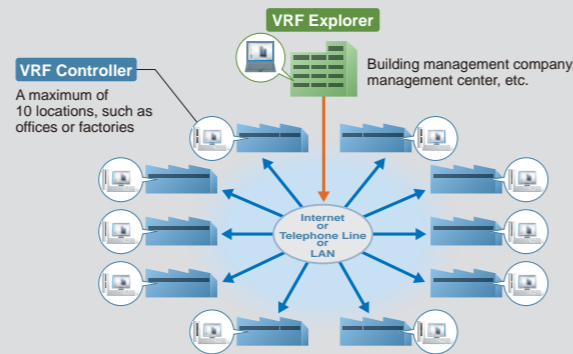

1 VRF Controller can be monitored from any number of VRF Explorers (Up to 5 connections simultaneously).

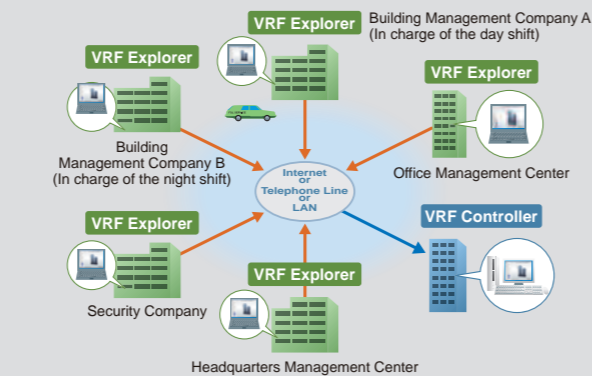

### Can be used for a variety of applications

#### Air conditioning management for large shopping malls or the outlets of nationwide franchises

- Remote centralized management can be used for nighttime only to manage the air conditioning of multiple stores, operate air conditioning for people working overtime, and checking to see if employees forgot to turn off the air conditioning after they leave.
- Multiple users via a LAN can control the air conditioning in the office, general affairs department, or janitor's room.
- The air conditioning for franchise locations nationwide can be centrally controlled from headquarters to facilitate operation status and control to save energy.



#### Air conditioning management of multiple buildings spread over a large site

- Batched operation of the factory buildings on a large site can be remotely conducted from the management office of the administration building to employ power saving operation.
- The headquarters can conduct centralized remote monitoring of the company's factories in outlying areas to improve the power saving effect for the entire company.
- Controlling the operation of each building and each classroom on campus makes it possible to reduce expenses by remotely controlling those spaces in accordance with the teaching schedule.



#### Provides high-quality building air conditioning service

- Service companies that manage buildings that are empty at night after the managers leave to go home can conduct centralized remote monitoring of the building without dispatching employees to the site, which allows them to monitor the air conditioning for multiple clients.
- The System Controller remote monitoring and control functions can be used to receive outsourcing business from small and medium size building owners to manage their air conditioning energy.
- Nighttime only remote monitoring of multiple properties after the people leave can be performed for areas that require 24-hour operation, such as server rooms, to monitor for problems.



### Security Support

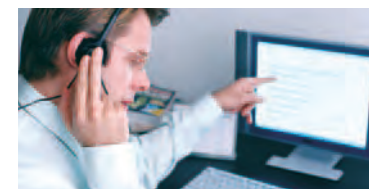

#### Employs SSL Encryption Technology

Encryption technology is used for communications to remote sites to prevent information from being stolen.



#### Detailed User Management

**User identification** : Authorization using user IDs and passwords is employed to prevent unauthorized access.

**Access authority** : The functions that can be used are restricted for individual login users to prevent unauthorized use.

### Schedule control

- Annual schedules can be set for each remote controller group / user defined group.
- Start / stop, operating mode, remote controller prohibition, and temperature settings can be set up to 144 times per day at 10 minute intervals for up to 101 configurations for each remote controller group.
- Settings can be made for periods straddling midnight.
- Allows programming of special settings for holidays, including public holidays, for a complete year.
- Low noise operation of outdoor unit can be scheduled.

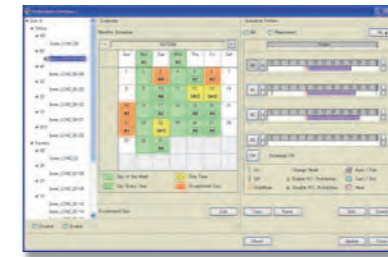

### Diverse control of indoor units

- Indoor unit operation state, operation mode, etc. are displayed
- Indoor unit start / stop and operation mode switching
- Temperature setting, Remote Controller prohibition.



### Error display & E-mail notification

Error is notified with popup message, audible sound and E-mail real time when error occurs. Error for the past 1 year are logged and can be reviewed later.

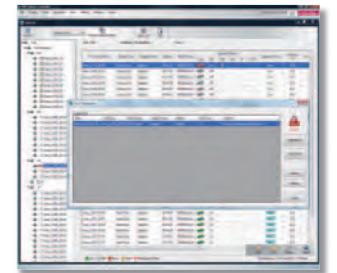

### Operating & control record

Displays the history of operation status and control.

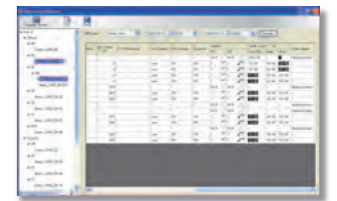

### Prohibition Setting

This prohibits changes to the operation mode, temperature, start / stop, etc.

### Multiple language display

Corresponds to 7 different languages (English, Chinese, French, German, Spanish, Russian, Polish)

### PERSONAL COMPUTER SPECIFICATIONS

The following chart shows the detail requirement for an AT compatible personal computer to run System Controller. Applies for both VRF Controller and VRF Explorer PC.

Operating system	<ul style="list-style-type: none"> <li>Microsoft® Windows® XP SP3 (32-bit) Professional (*1)</li> <li>Microsoft® Windows® Vista® SP2 (32-bit) Home Premium, Business (*2)</li> <li>Microsoft® Windows® 7 SP1 (32/64-bit) Home Premium, Professional (*2)</li> </ul> [Supported languages] (*1) English only (*2) English, Chinese, French, German, Russian, Spanish, and Polish
CPU	Intel® Core™ i3 2GHz or higher
Memory	2GB or more (Windows® XP, Vista®, 7 32-bit), 4GB or more (Windows® 7 64-bit)
HDD	40GB or more of free space
Display	1024 x 768 or higher resolution
Interface	USB port is required for each of the followings for Server PC ; <ul style="list-style-type: none"> <li>Wibu Key (Software protection key)</li> <li>Echelon® U10 USB Network Interface (Required for each VRF Network)</li> </ul> Ethernet port is required for remote connection using internet.
Accelerator	Requires the internal graphics accelerator be compatible with Microsoft® DirectX® 9.0
Software required	Adobe® Reader® 9.0 or later
Hardware required	DVD-ROM Drive

#### <OPTION AVAILABLE>

Energy Saving Software	UTY-PEGX(*1)	Additional support for energy saving function and Electricity Charge Apportionment using electricity meter.
------------------------	--------------	---

#### <PACKING LIST>

Name and shape	Quantity	Application
DVD-ROM	1	Includes the software and manuals for System Controller. Both VRF Controller and VRF Explorer software are included.
Wibu Key (Software protection key)	1	Software protection key to be inserted in a USB slot running System Controller. System Controller may only run on a PC with Wibu Key. However, Wibu key is not required for remote VRF Explorer software.

Personal computer must be field supplied. U10 USB Network Interface must be field supplied. Contact Echelon® Corporation or its local sales representative for detail.  
 Product Name : U10 USB Network Interface - TP/FT-10 Channel Model Number : 75010R  
 \*1: Energy Saving Software (UTY-PEGX) is available for the indoor units and the outdoor units after revision code B or later.  
 Microsoft® Windows® 8 will be supported.(Future release)

# Network Convertor

## UTY-VGGXZ1

- This Network Convertor is to be used for connecting single split system or Group Remote Controller (UTY-CGGY / UTY-CGGG) with the VRF network system.
- Please select the function by switching the dip switch during the installation.

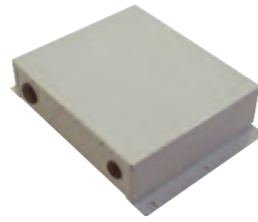

Max. connectable  
**16**  
single indoor units

Max. connectable  
**4**  
Group Remote Controllers

### Functions

#### Used for connecting single split system

- Split type systems can be centrally controlled from Touch Panel Controller or System Controller through connection to the VRF's network convertor.
- On / Off Control, Master control, Room temperature and Fan speed setting via the Network Convertor are available.
- One Network Convertor can be used to connect and control up to 16 single units.

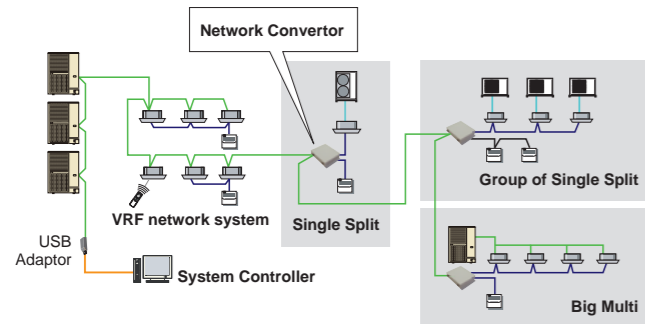

Please consult your distributor for connectable split type air conditioner. Up to 100 Network Convertors may be connected in single VRF network system. One Network Convertor is considered as a single refrigerant system, irrespective of the number of connected single models.

#### Used for connecting Group Remote Controller

4 Group Remote Controllers can be connected to a single Network Convertor (UTY-VGGXZ1).

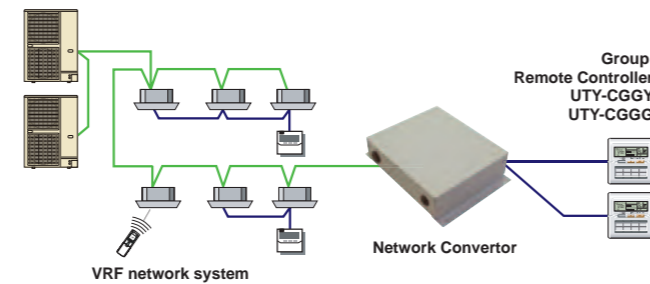

\* 2 refrigerant circuits can be covered by a single Network Convertor (UTY-VGGXZ1). Up to a total of 16 Network Convertors (UTY-VGGXZ1) and System Controller adaptors can be connected in a single VRF network system.

### Specifications

Model name	UTY-VGGXZ1
Power Supply	208-240V 50/60Hz, Single phase
Power Consumption (W)	8.5
Dimensions (H x W x D) (mm)	67 x 288 x 211
Weight (g)	1,500

### Dimensions (Unit : mm)

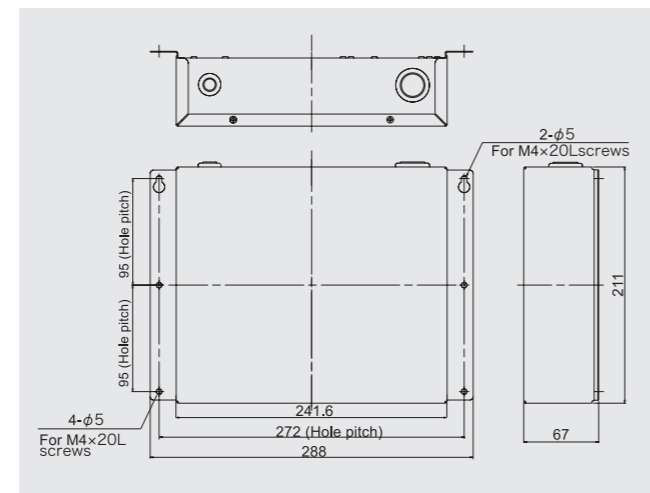

# Network Convertor for LONWORKS®

## UTY-VLGX

- For connection between VRF network system and a LONWORKS® open network for management of small to medium-sized BMS and VRF network system.
- The UTY-VLGX permits central monitoring and control of a VRF network system from a BMS through a LONWORKS® interface.
- Up to 128 Indoor units can be connected to one Network Convertor for LONWORKS®

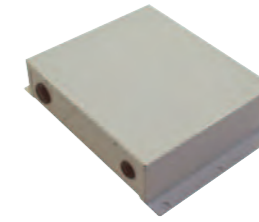

Max. controllable  
**4**  
Units to BMS

Max. controllable  
**100**  
Outdoor units

Max. controllable  
**128**  
Indoor units

### Installation example

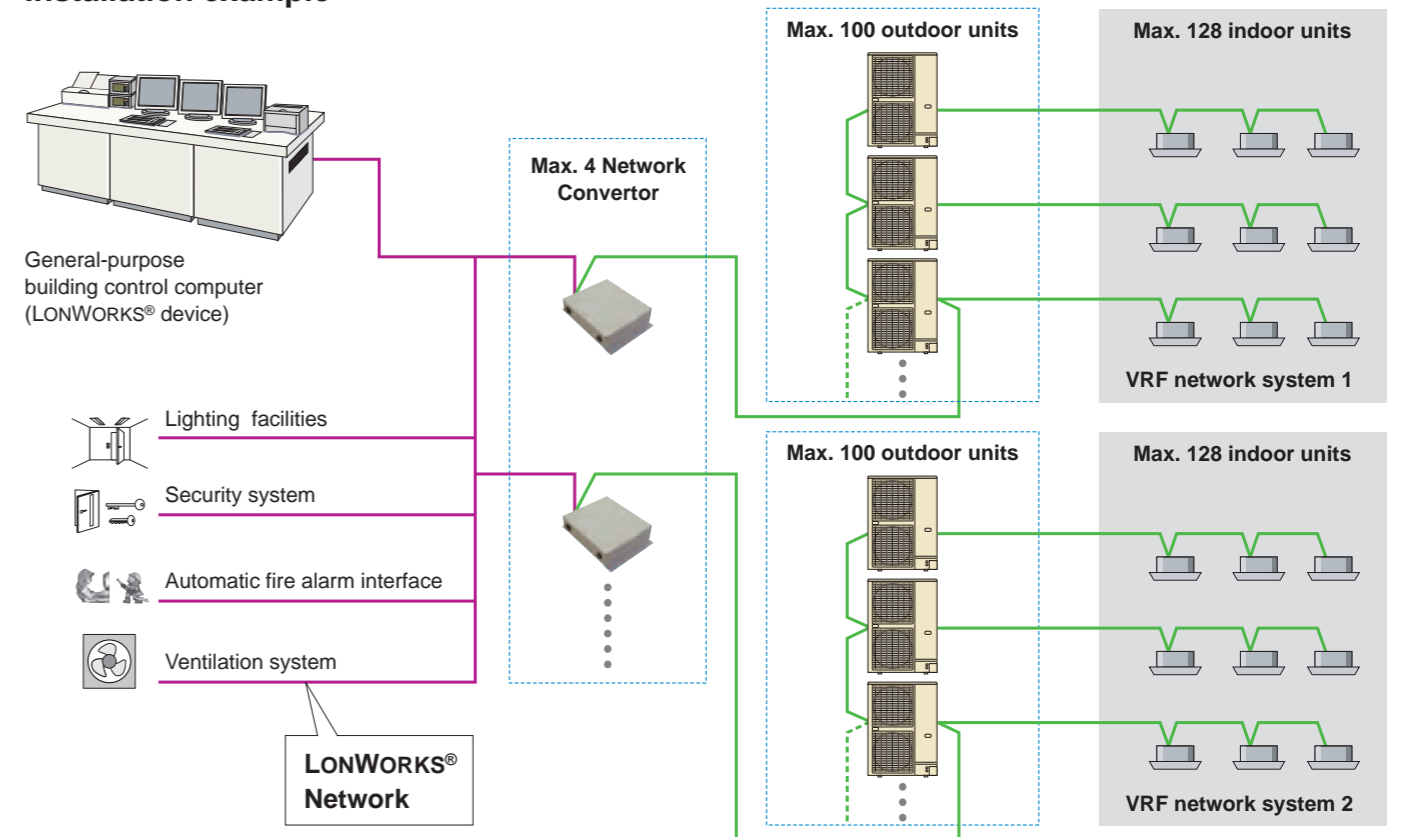

### Specifications

Model name	UTY-VLGX
Power Supply	208-240V 50/60Hz, Single phase
Power Consumption (W)	4.5
Dimensions (H x W x D) (mm)	67 x 288 x 211
Weight (g)	1,500

### Transmission specifications (BMS side)

Transmission speed	78 kbps
Transceiver	FT-X1 (Echelon® Corporation)
Transmission way form	Free topology
Terminal resistor	None (It attaches at the terminal of a network.)

### Dimensions (Unit : mm)

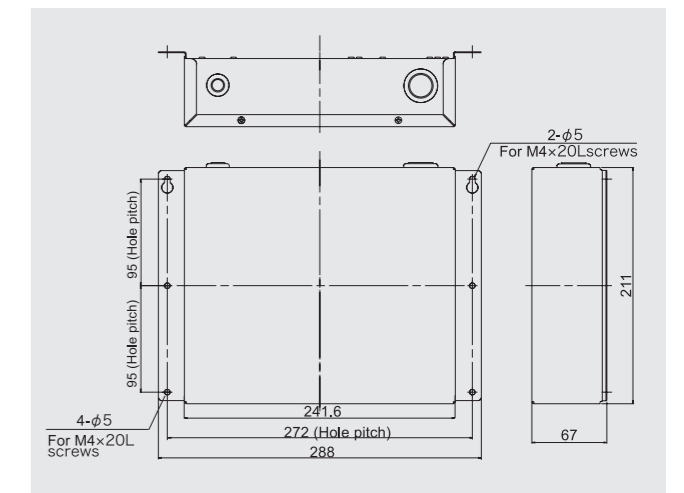

# BACnet® Gateway

Software

## UTY-ABGX

- It is possible to connect medium to large sized BMS to VRF network system via BACnet®, a global standard for open networks.
- A maximum of 1600 indoor units with 4 VRF network systems (a maximum of 400 indoor units & 100 outdoor units for one network system) can be connected to one BACnet® Gateway.
- It is possible to control or monitor VRF network system from BMS via BACnet® Gateway.
- Compatible with BACnet® (ANSI / ASHRAE-135-2004) application specific controller (B-ASC).
- Compatible with BACnet®/IP over Ethernet.
- Scheduling function, Alarm & Event functions as well as Electricity Change Apportionment function are provided in BACnet® Gateway.
- Connection between VRF network system to personal computer is possible via small U10 USB interface. However, both U10 USB interface & personal computer are field supplied items.
- Corresponds to 7 different languages, English, Chinese, French, German, Spanish, Russian, Polish.



Max. controllable  
**4**  
VRF network systems

Max. controllable  
**400**  
Outdoor units

Max. controllable  
**1,600**  
Indoor units

### Installation example

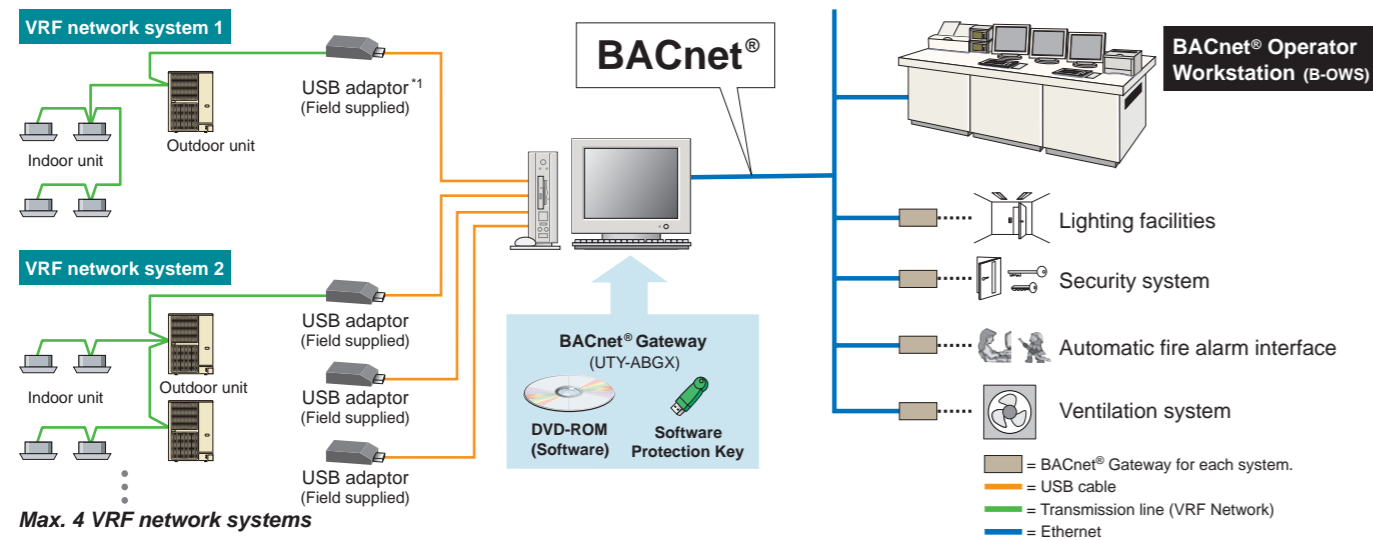

\*1: USB adaptor is U10 USB Network Interface of Echelon® Corporation.

### PERSONAL COMPUTER SPECIFICATIONS

Operating system	<ul style="list-style-type: none"> <li>• Microsoft® Windows® XP SP3 (32-bit) Professional</li> <li>• Microsoft® Windows® Vista® SP2 (32-bit) Home Premium, Business</li> <li>• Microsoft® Windows® 7 SP1 (32/64-bit) Home Premium, Professional</li> </ul> [Supported languages] English, Chinese, French, German, Russian, Spanish, and Polish
CPU	Intel® Core™ i3 2GHz or higher
Memory	2GB or more (Windows® XP, Vista®, 7 32-bit), 4GB or more (Windows® 7 64-bit)
HDD	40GB or more of free space
Display	1024 x 768 or higher resolution
Interface	USB port (x2-5) is required Ethernet port is required
Software required	Adobe® Reader® 9.0 or later
Hardware required	DVD-ROM Drive

#### <PACKING LIST>

Name and shape	Quantity	Application
DVD-ROM	1	Includes the software and manuals for BACnet® Gateway.
Wibu Key (Software protection key)	1	Software protection key to be inserted in a USB slot running BACnet® Gateway. BACnet® Gateway may only run on a PC with Wibu Key.

Personal computer must be field supplied. U10 USB Network Interface must be field supplied. Contact Echelon® Corporation or its local sales representative for detail.  
 Product Name : U10 USB Network Interface - TP/FT-10 Channel Model Number : 75010R  
 Microsoft® Windows® 8 will be supported.(Future release)

# Signal Amplifier

## UTY-VSGXZ1

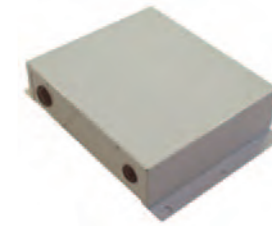

- Transmission Line length can be extended up to 3,600m with multiple Signal Amplifiers.
- Up to 40 signal amplifiers can be installed in a VRF network system.
- A signal amplifier is required,
  - (1) When the total wiring length of the transmission line exceeds 500m.
  - (2) When the total number of units on the transmission line exceeds 64.

### Installation example

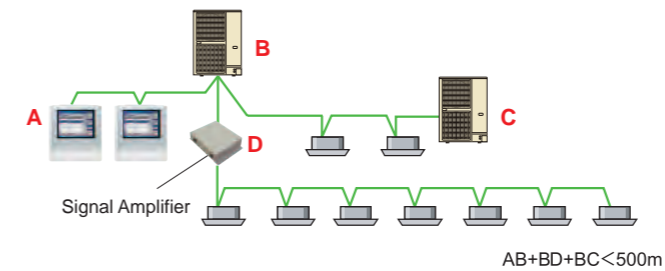

### Specifications

Model name	UTY-VSGXZ1
Power Supply	208-240V 50/60Hz, Single phase
Power Consumption (W)	4.5
Dimensions (H x W x D) (mm)	67 x 288 x 211
Weight (g)	1,500

### Dimensions (Unit : mm)

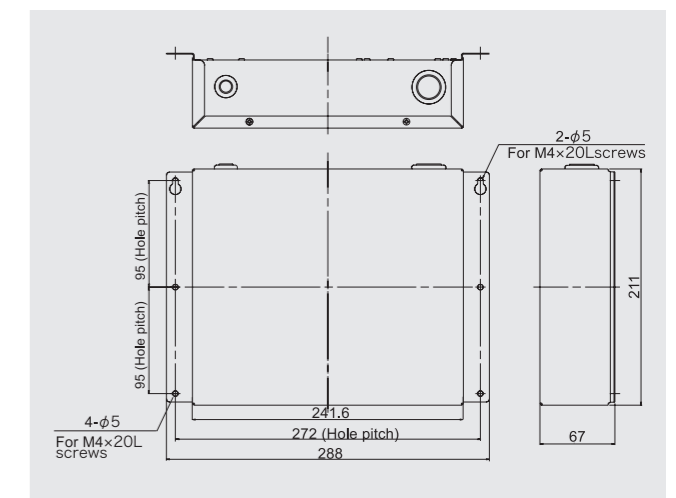

# External Switch Controller

## UTY-TEKX

Air conditioner switching can be controlled by connecting other sensor switches

- In combination with a field supply Card-Key Switch or other sensor, the External Switch Controller allows control of the ON / OFF, Room temperature, Fan speed and Master control functions. This makes this product suitable for installations such as hotel rooms.
- Card-key or other sensor switches are available as a field supplied parts.

### Installation example

Auto mode operation, which switches the cooling and the heating automatically, is enabled by using the sensor switch and External Switch Controller.

Note: All indoor units will operate in the same mode.

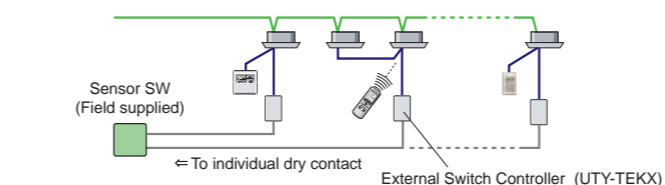
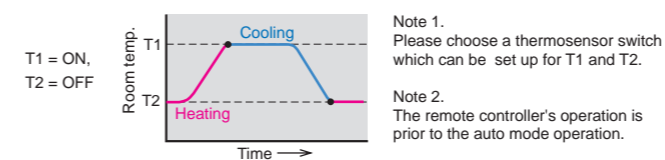

### Electrical wiring

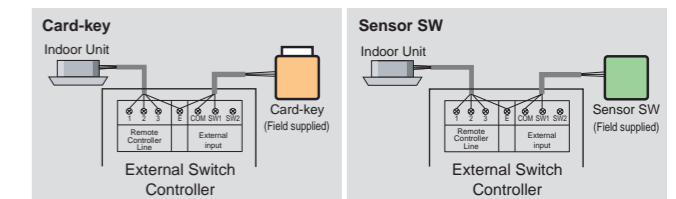

### Specifications

Model name	UTY-TEKX
Power Supply	DC 12V
Dimensions (H x W x D) (mm)	120 x 75 x 30
Weight (g)	100

DC12V is supplied by the indoor unit.

# Service Tool Software

## UTY-ASGX

Extensive monitoring and analysis functions for installation and maintenance.

- Operation status can be checked and analyzed to detect even the small abnormalities.
- Data collected and stored on site can be checked later, off-line, off-site for more detail analysis.
- One VRF network system with maximum number of up to 400 units can be monitored and controlled.
- Operation status and various sensor information can be monitored and checked real time in the form of list, refrigerant circuit diagram, graphs as well.
- Simple operation control functions are useful during maintenance.
- The recent error history can be retrieved from units on demand to perform analysis on the cause of the error, after connecting Service Tool to the VRF network system.
- Commissioning tool supports test runs, data storage for each unit and saving of data as CSV files, which may be formatted to create commissioning report.
- Connectable to any point of transmission line with USB adaptor<sup>1</sup> (field supplied)
- Connection between VRF network system to personal computer is possible via small U10 USB interface. However, both U10 USB interface & personal computer are field supplied items.
- 14 advanced functions are available for the VR-II series for through servicing and through shooting.
- The operating state (Solenoid valve) of RB unit can be checked.

\* 1: Service Tool (UTY-ASGX) will only support USB type network adaptor and will not support transmission adaptor of the traditional type(UTR-YTMA)

Max. Monitor  
**100**  
Outdoor units

Max. Monitor and control  
**400**  
Indoor units



## Wiring connection

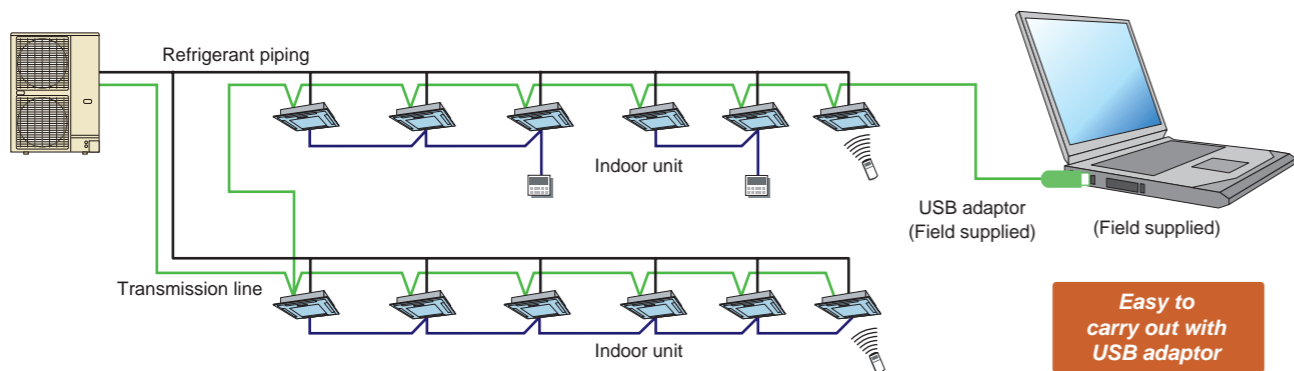

\*USB Adaptor is U10 USB Network interface of Echelon® Corporation.

## Functions

### 1) System List

Displays the overall operation status of all or specified units in the system in a list form.



### 2) Equipment Detail (Diagram)

Displays the detail information for sensor values, electrical components etc. for the specified units in schematic. The information here can be used along with the detail information in list form, to check the operation status of units and make detail analysis on the cause, in case an error occurs.



### 3) Equipment Detail (List)

Displays the detail information for sensor values, electrical components etc. of units in a specified refrigerant system in list form. The information here can be used along with the detail information in diagram form, to check the operation status of units and make detail analysis on the cause, in case an error occurs.



### 4) Operation History

The indoor units or outdoor unit operation history can be recorded. The displayed operation history can be printed out and saved to a CSV file.



### 5) Error History

Displays the error information for each unit. The error information can sequentially be displayed up to 50 items as they occur starting with the latest error.



### 6) Remote File Download

Operation and error history data can be downloaded. Only the required data may be downloaded specifying the refrigerant system, unit and time range.

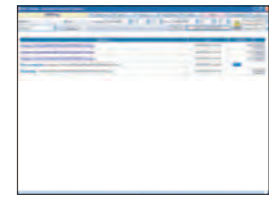

### 7) Commissioning Tool

Test run commands can be executed with this tool. During test running, the outdoor unit / indoor unit sensor data can be saved (commissioning log data). After the end of test running, this data can be exported in CSV file format.

### 9) Remote Setting \*

Function (Field) Setting for indoor unit is realized remotely



### 8) Network Topology Analyzer \*

A list of units connected to the VRF system network is displayed in network segments in tree form.



### 10) System Time Setting \*

An arbitrary time is set for all the remote controllers within the system.

### 11) Central Release \*

The operation setting restriction function of the indoor units set from the controller can be forcibly released.(remote controller inhibit, temperature upper/lower limit setting)

### 12) Model Name Writer \*

An arbitrary model name can be written to the target unit.

### 13) Error Memory Reader \*

When an error occurs at an outdoor unit, the operation data records before the error are acquired over a network and saved to a CSV file.

### 14) Time Guard Information \*

Reference data for judging the maintenance period of indoor and outdoor units (compressor,FAN, etc. integrated time) is output to a CSV file.

Note: To perform "Error Memory Reading", Service Tool and the corresponding outdoor unit must be connected directly with each other. Refer to the Operation Manual of the Service Tool for detail.

\*: Supported by Ver. 1.1 or later

## PERSONAL COMPUTER SPECIFICATIONS

Operating system	<ul style="list-style-type: none"> <li>• Microsoft® Windows® XP SP3 (32-bit) Professional</li> <li>• Microsoft® Windows® Vista® SP2 (32-bit) Home Premium, Business</li> <li>• Microsoft® Windows® 7 SP1 (32/64-bit) Professional</li> </ul> [Supported languages] English only
CPU	1GHz or higher
Memory	512 MB or more (Windows® XP 32-bit) 1GB or more (Windows® Vista®, 7 32-bit) 2GB or more (Windows® 7 64-bit)
HDD	10GB or more of free space
Display	1024 x 768 or higher resolution
Interface	USB port for U10 USB Network Interface and Software protection key
Software required	Internet Explorer 7.0 or 8.0 or 9.0 / Adobe® Reader® 9.0 or later
Hardware required	DVD-ROM Drive

### <PACKING LIST>

Name and shape	Quantity	Application
DVD-ROM	1	Includes the software and manuals for Service Tool.
Wibu Key (Software protection key)	1	Software protection key to be inserted in a USB slot running Service Tool. Service Tool may only run on a PC with Wibu Key.

Personal computer must be field supplied. U10 USB Network Interface must be field supplied. Contact Echelon® Corporation or its local sales representative for detail.  
Product Name : U10 USB Network Interface - TP/FT-10 Channel Model Number : 75010R  
Microsoft® Windows® 8 will be supported.(Future release)

# Web Monitoring Tool Software

## UTY-AMGX

### Product features

- Troubleshooting is performed by monitoring each unit remotely during periodical system checks off-site.
- Operation status can be checked and analyzed to detect even the smallest abnormalities.
- Four VRF network systems each with 400 units, with maximum number of up to 1,600 units can be monitored and controlled.
- Operation status and various sensor information can be monitored and checked real time in the form of list, refrigerant circuit diagram, and graphs as well.
- The monitoring data in a remote side can be optionally downloaded. And, this data can be displayed in off-line mode of the Service Tool.
- Error notification can be automatically transmitted to several locations using the internet<sup>\*1</sup>.
- Monitoring side computer is not required to install special software, requires only general web browser.
- Connectable to any point of transmission line with U10 USB interface<sup>\*2</sup> (field supplied)
- Connection between VRF network system to personal computer is possible via small U10 USB interface. However, both U10 USB interface & personal computer are field supplied items.
- The operating state (Solenoid valve) of RB unit can be checked.

\* 1: USB of internet mail system required.

\* 2: Web Monitoring Tool (UTY-AMGX) will only support USB type network adaptor and will not support transmission adaptor of the traditional type (UTR-YTMA).

**4**  
VRF network systems  
can be supported

Max. Monitor  
**400**  
Outdoor units

Max. Monitor and control  
**1600**  
Indoor unit  
can be monitored

### Web Monitoring System

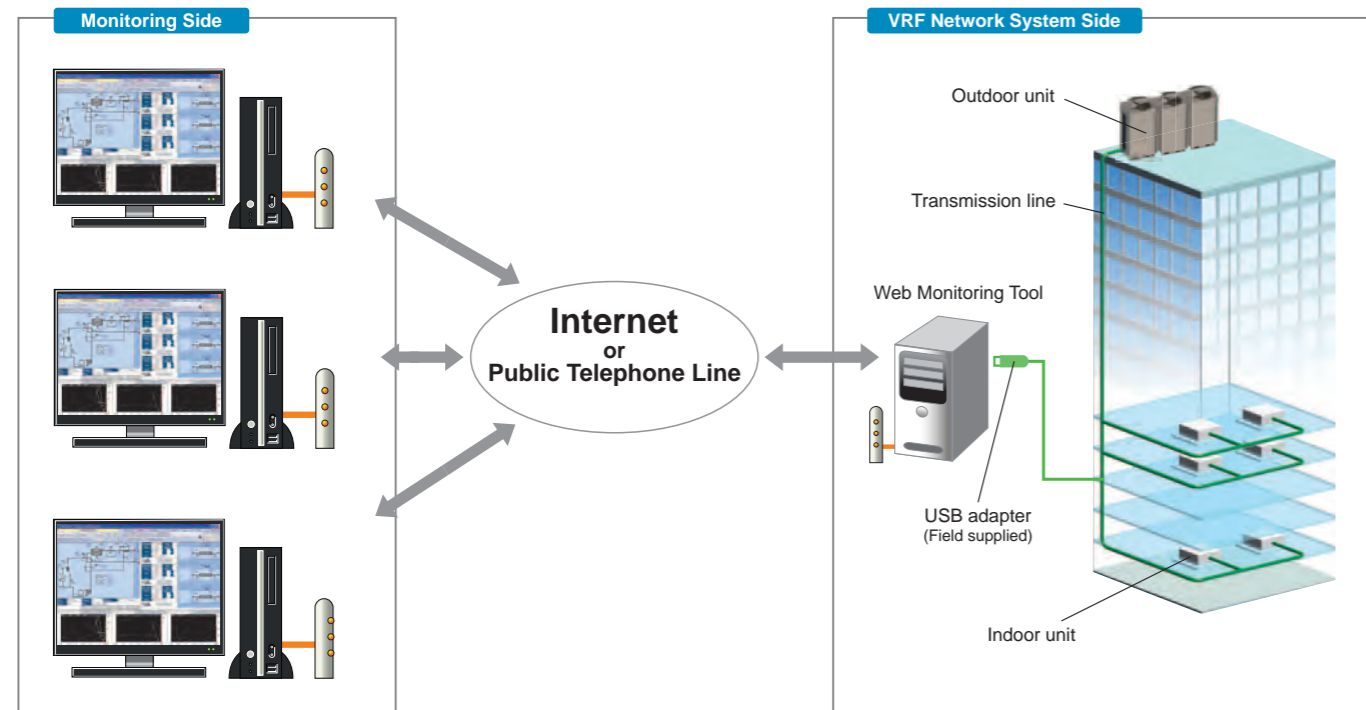

### System components

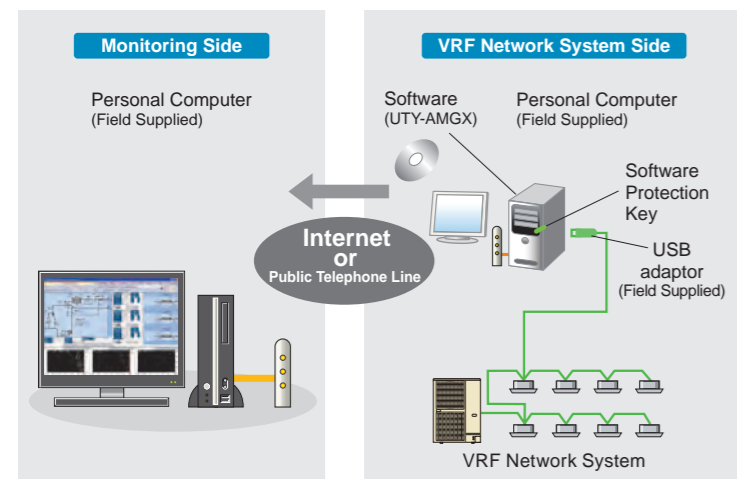

### Support 4 VRF network systems

USB adaptor (max. 4 adaptors per PC) permit, monitoring of up to 1,600 indoor units.  
Suitable for large-scale buildings or hotels.

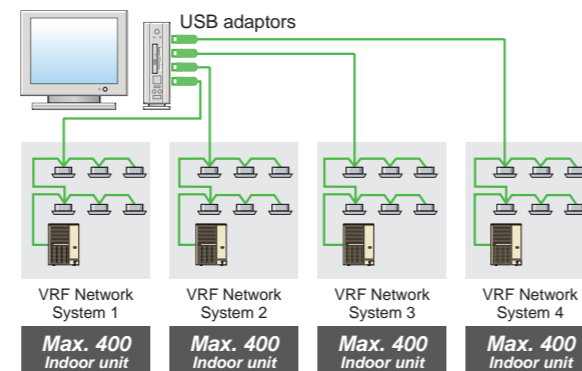

### COMPARISON TABLE

No.	Item	Service Tool UTY-ASGX	Web Monitoring Tool UTY-AMGX	
			VRF network system Side	Monitoring Side
1	Interchangeability of equipment	●	●	●
2	Indication of equipment list	●	●	●
3	Operation control	●	●	—
4	Indication of refrigerant circuit diagram	●	●	●
5	Commissioning tool	●	●	—
6	Monitoring of equipment information	●	●	●
7	Monitoring of operating condition	●	●	●
8	Monitoring of sensor data	●	●	●
9	Storage and CSV output of operating history (sensor data)	●	●	●
10	Indication of trend graph	●	●	●
11	Printing of trend graph	●	●	●
12	Monitoring and screen display of abnormalities	●	●	●
13	E-mail automatic transmission of abnormalities	—	● <sup>*1</sup>	—
14	Setting for user level	—	●	—
15	Network Topology Analyzer *	●	●	—
16	Remote Setting *	●	●	—
17	System Time Setting *	●	●	—
18	Central Release *	●	●	—
19	Model Name Writer *	●	—	—
20	Error Memory Reader *	●	—	—
21	Time Guard Information *	●	●	●

\*: Supported by Ver. 1.1 or later

\*1: it is available only during a connection to the Internet.

### PERSONAL COMPUTER SPECIFICATIONS

Operating system	<ul style="list-style-type: none"> <li>• Microsoft® Windows® XP SP3 (32-bit) Professional</li> <li>• Microsoft® Windows® Vista® SP2 (32-bit) Home Premium, Business</li> <li>• Microsoft® Windows® 7 SP1 (32/64-bit) Professional</li> </ul> [Supported languages] English only
CPU	1GHz or higher
Memory	1GB or more (Windows® XP, Vista®, 7 32-bit) 2GB or more (Windows® 7 64-bit)
HDD	40GB or more of free space
Display	1024 x 768 or higher resolution
Interface	USB port (for U10 USB Network Interface Max.4 , Software protection key) Either of the following interface is required for remote connection: <ul style="list-style-type: none"> <li>• Public Telephone Line : Modem is required</li> <li>• Internet using LAN : Ethernet port is required</li> </ul>
Software required	Internet Explorer 7.0 or 8.0 or 9.0 / Adobe® Reader® 9.0 or later
Hardware required	DVD-ROM Drive

#### <PACKING LIST>

Name and shape	Quantity	Application
DVD-ROM	1	Includes the software and manuals for Web Monitoring Tool.
Wibu Key (Software protection key)	1	Software protection key to be inserted in a USB slot running Web Monitoring Tool. Web Monitoring Tool may only run on a PC with Wibu Key.

Personal computer must be field supplied. U10 USB Network Interface must be field supplied. Contact Echelon® Corporation or its local sales representative for detail.

Product Name : U10 USB Network Interface - TP/FT-10 Channel Model Number : 75010R  
Microsoft® Windows® 8 will be supported.(Future release)



# Energy Recovery Ventilator

Models

- UTZ-BD025B
- UTZ-BD035B
- UTZ-BD050B
- UTZ-BD080B
- UTZ-BD100B

Energy recovery ventilator unit offers maximum comfort and greater energy savings.



## Heat exchange ventilation and normal ventilation

### Heat exchange ventilation

When a room is cooled or heated, the exhausted cooling / heating energy is recovered by heat-exchange ventilation.

### Normal ventilation

This is used in spring and autumn, when rooms are not cooled or heated, that is, when there is little difference between the indoor and outdoor air conditions. In addition, at night during the hot season, when the outside air temperature drops the outside air is drawn inside without heat exchange, alleviating the load on the air conditioning equipment.

Adopts a highly efficient counter-flow heat exchange element

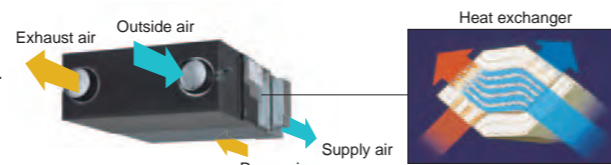

## Energy efficiency and ecology

Energy consumption is dramatically reduced by using a counterflow heat-exchange element. Air conditioning load is reduced by approximately 20%, resulting in significant energy savings. Recovers up to 77% of the heat in the outgoing air.

**20%**  
Energy saving

### Features of heat exchange element

With the cross-flow element, air moves in a straight line across the element. With the counter-flow element, air flows through the element for a longer time (longer distance), so the heat-exchange effect remains unchanged.

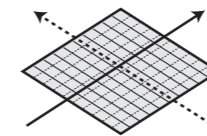

Other element  
(Cross-flow element)

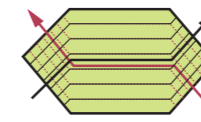

Fujitsu element  
(Counter-flow element)

## Slim shape and easier installation

Counter-flow heat exchange element used for reduced noise and slimmer, more compact body shape.

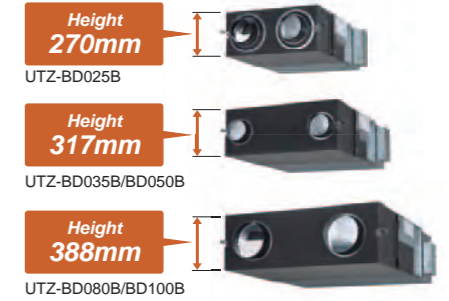

## Reverse mountable direct air supply / exhaust system

Adoption of straight air supply / exhaust system: Duct design is simplified because the air supply / exhaust ducts are straight.

Since each unit can be mounted in reverse position, only one inspection hole is needed for two units: Two units can share one inspection hole so duct work is easier and more flexible.

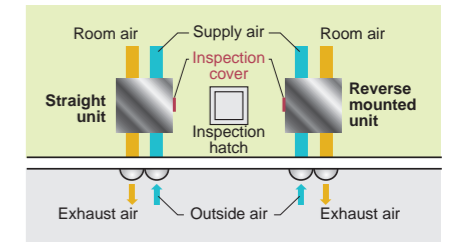

## Quiet operation

Significantly reducing low pressure loss and noise allows low-noise operation.

## Extended range of an external static pressure

An external static pressure is improved by adopting a powerful fan motor.

This allows for application in a wide variety building.

## Specifications

Rated flow rate		250 m³/h	350 m³/h	500 m³/h	800 m³/h	1000 m³/h		
Model No.		UTZ-BD025B	UTZ-BD035B	UTZ-BD050B	UTZ-BD080B	UTZ-BD100B		
Power source		220 - 240V, 50Hz						
HEAT EXCHANGE VENTILATION	Input power	Extra high / High / Low	W	128 / 123 / 96	190 / 185 / 168	289 / 225 / 185	418 / 378 / 295	464 / 432 / 311
	Air flow rate	Extra high / High / Low	m³/h	250 / 250 / 190	350 / 350 / 240	500 / 500 / 440	800 / 800 / 630	1000 / 1000 / 700
	External static pressure	Extra high / High / Low	Pa	105 / 95 / 45	140 / 60 / 45	120 / 60 / 35	140 / 110 / 55	105 / 80 / 75
	Temperature Exchange Efficiency	Extra high / High / Low	%	75 / 75 / 77	75 / 75 / 78	75 / 75 / 76	75 / 75 / 76	75 / 75 / 79
	Energy Exchange Efficiency Cooling	Extra high / High / Low	%	63 / 63 / 65	66 / 66 / 71	62 / 62 / 64	65 / 65 / 68	65 / 65 / 70
	Energy Exchange Efficiency Heat pump	Extra high / High / Low	%	70 / 70 / 72	69 / 69 / 73	67 / 67 / 69	71 / 71 / 74	71 / 71 / 76
Sound pressure level	Extra high / High / Low	dB*	31.5 / 30.5 / 26.5	33 / 31 / 25.5	37.5 / 35.5 / 32.5	37.5 / 37 / 34.5	38.5 / 37.5 / 34.5	
NORMAL VENTILATION	Input power	Extra high / High / Low	W	128 / 123 / 96	190 / 185 / 168	289 / 225 / 185	418 / 378 / 295	464 / 432 / 311
	Air flow rate	Extra high / High / Low	m³/h	250 / 250 / 190	350 / 350 / 240	500 / 500 / 440	800 / 800 / 630	1000 / 1000 / 700
	External static pressure	Extra high / High / Low	Pa	105 / 95 / 45	140 / 60 / 45	120 / 60 / 35	140 / 110 / 55	105 / 80 / 75
	Sound pressure level	Extra high / High / Low	dB*	31.5 / 30.5 / 26.5	33 / 31 / 25.5	38.5 / 38 / 32.5	37.5 / 37 / 34.5	40.5 / 39.5 / 36.5
Dimensions (W x D x H)		mm		882 x 599 x 270	1050 x 804 x 317	1090 x 904 x 317	1322 x 884 x 388	1322 x 1134 x 388
Weight		kg		29	49	57	71	83
Outlet duct diameter		mm		150	150	200	250	250
Operation range		°C		-10 ~ 40	-10 ~ 40	-10 ~ 40	-10 ~ 40	-10 ~ 40
Maximum humidity		%		85	85	85	85	85

\* The noise level must be measured 1.5 m below the centre of the unit.

## Dimensions (Unit : mm)

Models: UTZ-BD025B / UTZ-BD035B / UTZ-BD050B / UTZ-BD080B / UTZ-BD100B

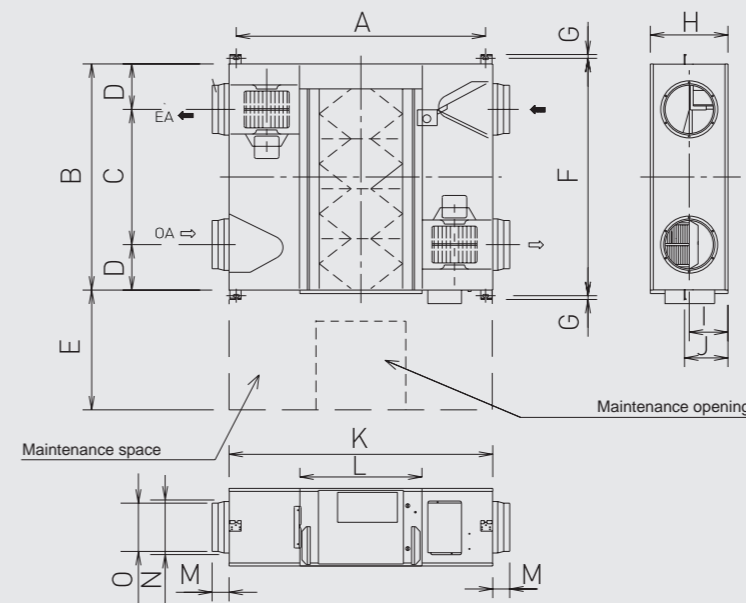

	UTZ-BD025B	UTZ-BD035B	UTZ-BD050B	UTZ-BD080B	UTZ-BD100B
A	810	978	1018	1250	1250
B	599	804	904	884	1134
C	315	580	640	428	678
D	142	112	132	228	228
E	600	600	600	600	600
F	655	860	960	940	1190
G	19	19	19	19	19
H	270	317	317	388	388
I	135	159	159	194	194
J	159	182	182	218	218
K	882	1050	1090	1322	1322
L	414	470	470	612	612
M	95	70	127	85	85
N	219	162	210	258	258
O	144	144	194	242	242

# Auto Louver Grille Kit (Option)

Models

- UTD-GXSA-W
- UTD-GXSB-W
- UTD-GXSC-W

Simple flat Auto Louver will provide comfort airflow and harmonize with luxury interior.

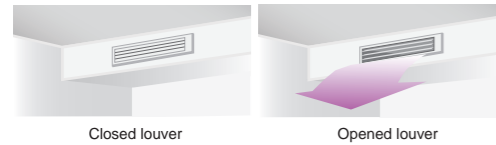

## Flexible Control

- **Operation with indoor unit**  
Auto Louver can be operated by synchronizing remote controller of indoor unit.
- **UP and Down auto swing**
  - Auto airflow direction and auto swing
  - 4 steps selectable
- **Auto-closing louver**  
When operation of indoor unit is stopped, the louver will automatically close.

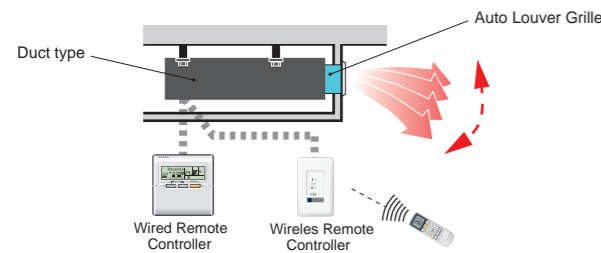

## Dimensions

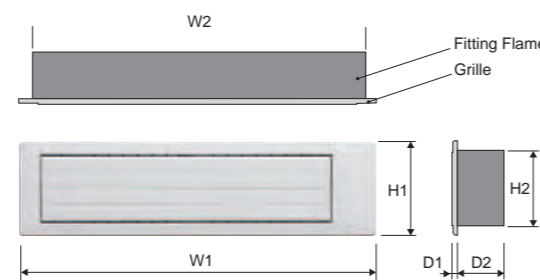

Model Name	W1	W2	H1	H2	D1	D2
UTD-GXSA-W	683	645	180	148	9	84
UTD-GXSB-W	883	845				
UTD-GXSC-W	1,083	1,045				

Unit: mm

## Specifications

Model name	UTD-GXSA-W		UTD-GXSB-W		UTD-GXSC-W	
Applicable Indoor Unit	ARXD07/09/12/14GALH		ARXD18GALH		ARXD24GALH	
Power Supply	Connecting with Control box of indoor unit					
Fixing of Auto Louver Grille	Screw fixing to Flange or Square Duct					
Extension Square Duct Limit	1.0m (Max. duct length between indoor unit and Grille)					
Net Dimension (H x W x D)	mm (inch)	180x683x(84+9) [7-3/32x26-7/8x(3-5/16+11/32)]	180x883x(84+9) [7-3/32x34-3/4x(3-5/16+11/32)]	180x1083x(84+9) [7-3/32x42-5/8x(3-5/16+11/32)]		
Weight	Net	kg	2.0 (4.4)	2.5 (5.6)	3.0 (6.7)	
	Gross	(lb.)	3.0 (6.7)	3.5 (7.8)	4.0 (8.9)	
Color	White					
Louver Motor	Stepping Motor					
Accessories	Fitting Flame, etc.					
Operation range	Cooling	°C (°F)	18 to 32 (64 to 90)			
		% RH	80% or less			
	Heating	°C (°F)	16 to 30 (60 to 88)			

# Building Information Modeling (BIM)

FUJITSU provides the Building Information Modeling (BIM) object models and contents for our VRF system and some products to the architect, designer and contractor using Autodesk® Revit® technology from our Website and Autodesk® Seek Website, etc.

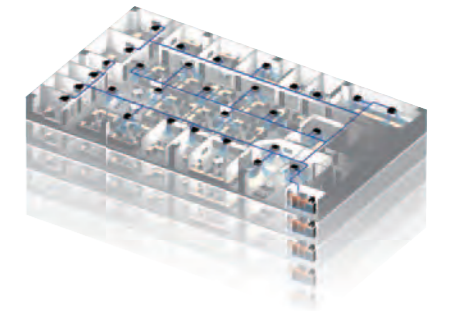

## BIM Object Models Ensure Proper Design

### Many products available

We provide BIM data for indoor units, outdoor units, and accessories. We will continue to create and provide products to support the global market.  
Object models: VRF "AIRSTAGE V-II" /8 Rooms Multi "HF1" / Energy Recovery Ventilator  
Files : Indoor units 75 files / Outdoor units 22 files / Options 15 files

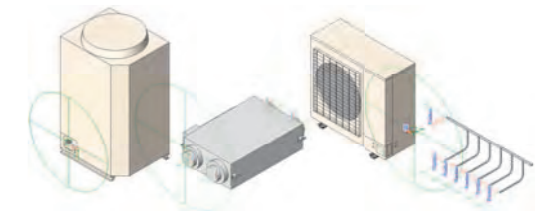

### 3D and 2D product data

We provide 3D data that is similar to the product appearance. 2D CAD design operations are supported and 2D display is also provided. The data can also be output in other formats, such as DXF and DWG, which are used by other design CAD.

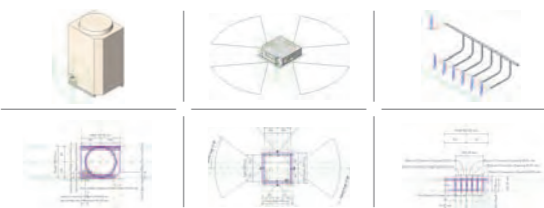

### Installation limitation

The equipment installation limitation range is shown. The distance range from the wall, etc., is automatically displayed to make it easy to provide highly reliable layout designs.

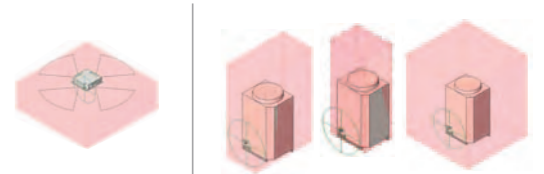

### Installation information

Other information, such as symbols showing the airflow direction that are required for installation drawings, is built in and can be automatically reflected in 2D drawings. Installation drawings can be created easily.



### Product specifications & Link information

Contains the basic information required for air conditioner design, including unit size, capacity, input power, noise, and airflow rate.  
\*: URL: <http://airstage.fujitsu-general.com>

### Data volume

Fujitsu Revit® files are small, requiring very little system resources.

### Required software

- |                                  |             |
|----------------------------------|-------------|
| Autodesk® Revit® series software | Data format |
| •Autodesk® Revit® Architecture   | •RFA        |
| •Autodesk® Revit® MEP            |             |
| •Autodesk® Revit® Structure      |             |

Product parameter	Link
Power source Input power Capacity Airflow rate Sound pressure level Dimensions Weight Connection pipe diameter Refrigerant Material/Color	+ FUJITSU GENERAL Website*

\* : URL:<http://www.fujitsu-general.com/index.html>

# Design Simulator

Enter your requirements, select your controls and options, design your layout and let the program do the rest.

Put the charts and pens away and design your projects on your computer with ease using the Design Simulator. Everything from selecting indoor and outdoor units, allocating controls and optional parts to designing the piping and wiring systems is made easier using the program's built-in features. Once your project is designed take advantage of the Export functions to easily get materials lists, product specifications, refrigerant calculations and more - it'll even export to Word or Excel formats, and group the relevant CAD data for your project.

## 1) Input Project Details

Enter the details of the project (optional)



## 2) Selection of Series

Select which series of equipment you are after, systems which share common units are grouped together.



## 3) Select Indoor units

Enter the Indoor Unit Requirements and conditions - then use automatic or manual selection to determine the unit to suit your needs.

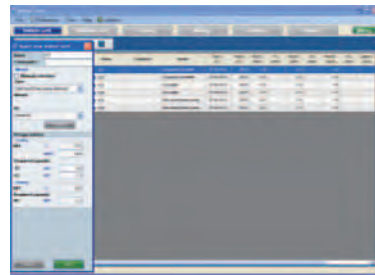

## 4) Select Outdoor Units

Add Indoor units to each system, then determine the Outdoor unit to suit your needs. If indoors in Step 3 were selected using Auto selection, Step 4 may reselect these indoors to suit the actual capacity

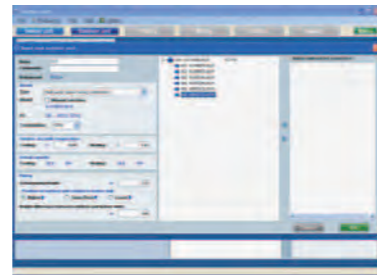

## 5) Piping Diagram / Input piping lengths

Piping diagrams are automatically created for each refrigerant system and information for each unit is automatically displayed. When the piping lengths are added the refrigerant charge is calculated and any additional refrigerant is shown.

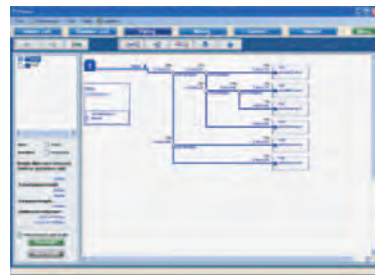

## 6) Wiring Diagram / Grouping of Remote Controllers

Wiring and remote control diagrams are automatically created for each refrigerant system. Set remote controller groups and addition of unit accessories and optional parts here.

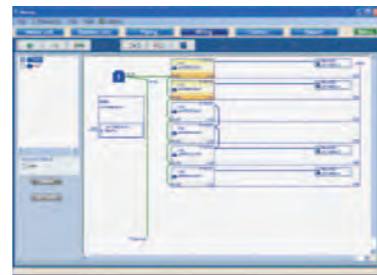

## 5) Central Controller and Converter options

Select any central controllers and converters that are to be used on the system. There is an Auto function available to let the program determine home many of each control you require for the system as designed.



## 8) Display and Export Project Report

View materials list for the project. Select which components are to be included into report and then export as csv, rtf or dxf format. You can also include the CAD data in your export to suit the models on your project - in 2D DXF or 3D RFA formats.

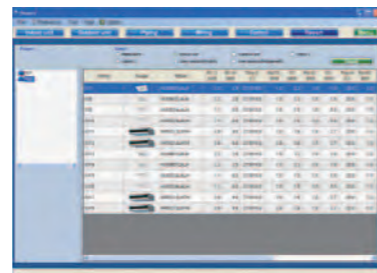

\*For further assistance, follow the link in the program to the online Movie Manual to view step by step explanations of all you need to know.

## Select Your Preferences

Select your language, region, default unit names and your preferred units of measurement. The program will then perform the required calculations and return the results in the format you want to see. Once this is done once, the program will remember your choices for future use.



## Update your Design Simulator

The information specific to your project can be exported in a number of industry standard file formats.

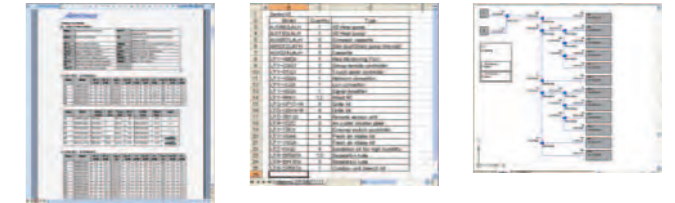

- Word format (rtf)
- Excel format (csv)
- AutoCAD format (DXF)
- 2D Data (DXF) • 3D Data (RFA)

## Update your Design Simulator

Database can be easily updated online using AutoUpdate function through FTP. Once you hit update, the program will connect to the online server and tell you if a newer version is available.

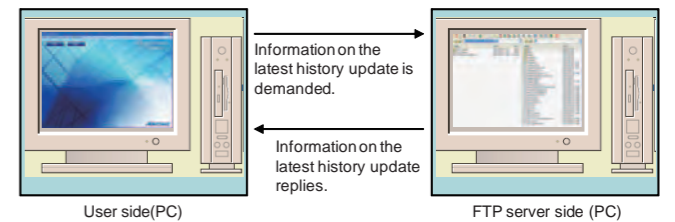

## Installation Requirements

Software	Design Simulator	
Operating System	Microsoft Windows XP / Vista / 7	
System Requirements	Hardware	CPU: 500 MHz or faster Memory: 2GB (Vista/7) 512MB (XP) or more HDD: 1GB or more
	Display	Resolution: 1024 x 768 or higher
	Software	Internet Explorer 7.0 or newer Adobe Reader 9.0 or newer Microsoft Word 2003 or newer

## Program Features and Specifications

Preferences	Language	Choose from 26 different languages
	Brand Setting	Select Fujitsu or General for products specific to your region
	Unit Naming	Choose default name for automatic naming of Indoor and Outdoor Units. i.e. Indoor = FCU, IU or AC. Outdoor = CU or OU
	Measurement Unit Setting	Set your preferred measurement units for Temperature, Unit and Piping Size, Weight, Capacity and Airflow
Model Selection Options	Automatic Selection for Indoor Units, Outdoor Units, Piping and Wiring using the criteria you enter	
	Manually select the units of your choice	
	Select from suggested Optional parts to suit your systems	
System Design	Select from Controllers / Adapters / Convertors for your project	
	Automatic creation of piping and wiring diagrams for the systems you designed	
Project and Model Information	Modify the piping and wiring diagrams to suit your specific installation	
	Materials List	
	Product Detail (Specifications, Options, Photographs)	
	Piping and Wiring Diagrams	
	Additional Refrigerant Calculation automatic when piping lengths are entered	
Report Export Formats	CAD Data for models specific to your project in 2D - DXF or 3D RFA formats	
	Word (RTF format)	
	Excel (CSV format)	
	DXF format	
Update Options	Automatic Update via FTP through internet (AutoUpdate button)	
	Download the latest version of the program if AutoUpdate is unavailable due to firewall etc	

Note: Models are added and updated constantly, specifications are subject to change without notice. Update your system to ensure you have the latest information.

# Optional Parts

## Connection Units

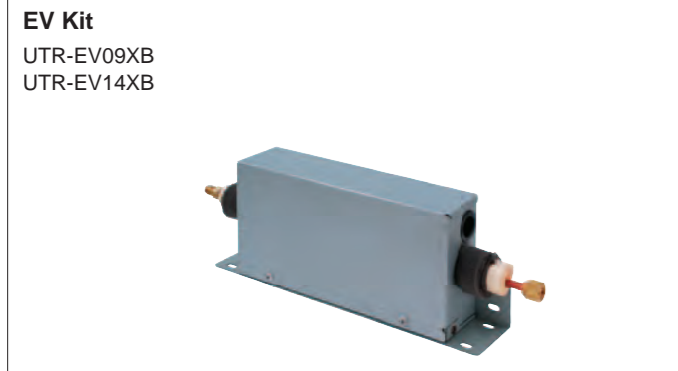
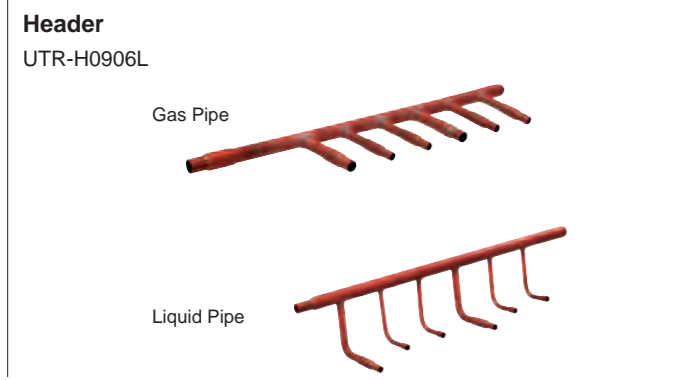
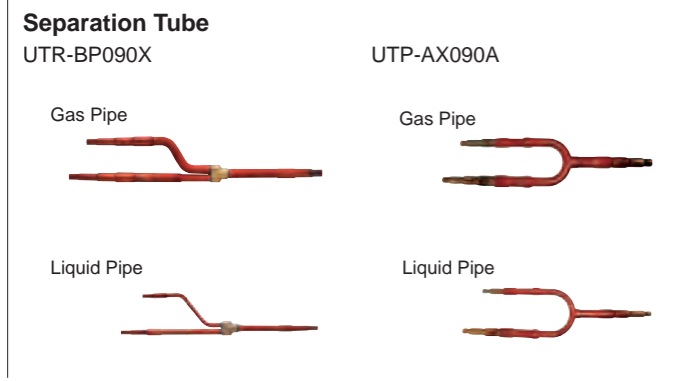

## Specifications

Separation Tube	
Model name	UTR-BP090X or UTP-AX090A
Total cooling capacity of indoor unit (kW)	28.0 or less

Header	
Model name	3-6 Branches      UTR-H0906L
	3-8 Branches      UTR-H0908L
Total cooling capacity of indoor unit (kW)	28.0 or less

EV Kit		
Model name	UTR-EV09XB	UTR-EV14XB
Application Model	AS*E07GACH AS*E09GACH	AS*E12GACH AS*E14GACH

AS\*: ASY(FUJITSU), ASH(GENERAL)

# Applications

There are many applications for Airstage VRF systems including such markets as education, healthcare, hospitality, utilities, office buildings, apartment buildings, condominiums, and restaurants. Note: VRF Heat Recovery system provides simultaneous Heating and Cooling. System operates both Heating mode and Cooling mode.

## Multi-Tenant Dwellings



VRF improves the quality of multi-tenant buildings while reducing tenant complaints. High quality VRF systems let owners save on energy costs and reduced maintenance costs. With VRF, each tenant has individual control over the temperature setting for the comfort of their home.

### QUALITY

By delivering quiet, efficient heating and cooling, VRF improves the quality of multitenant buildings and reduces tenant complaints.

### ENERGY SAVINGS

Efficient VRF systems reduce the total energy costs for buildings over most other options. High quality systems reduce maintenance and service costs.



### INDIVIDUAL BILLING

Using the Energy Charge Apportionment feature, landlords can easily bill each tenant for the percentage of total energy the individual tenant consumes.

### INDIVIDUAL COMFORT

With VRF, each tenant can have their own controller to set their room temperature for their maximum comfort.

### CONVENIENT CENTRAL CONTROL

Landlord can monitor and control all indoor units from a central location. Landlord can even troubleshoot or solve tenant complaints remotely.



### QUIET

Indoor units ensures a quiet, comfortable living environment for all tenants.