

AIRSTAGE™

J **SERIES**

Variable Refrigerant Flow System

Multi Air Conditioning System for Buildings

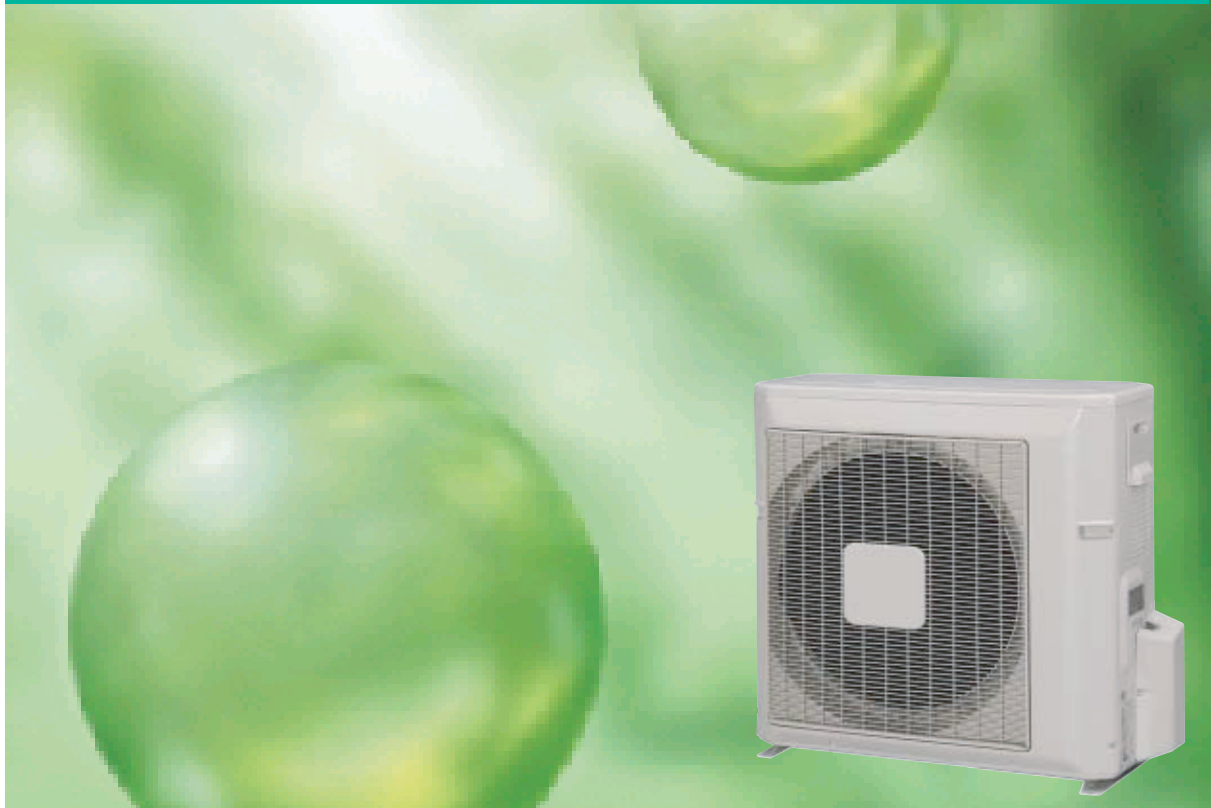

HEAT PUMP & COOLING ONLY TYPE

DESIGN & TECHNICAL DATA

CONTENTS

1.GENERAL INFORMATION

1-1 FEATURES OF SYSTEM	01 - 01
1-2 MODEL LINE UP	01 - 06

2.CONTROL SYSTEM

2-1 CONTROL SYSTEM	02 - 01
2-1-1 LINE UP OF CONTROLLERS	02 - 01
2-1-2 SYSTEM CONFIGURATION	02 - 02
2-1-3 FEATURES OF CONTROL SYSTEM	02 - 02
2-2 CONTROL UNITS	02 - 03
2-2-1 WIRELESS REMOTE CONTROLLER(Accessory)	02 - 04
2-2-2 WIRED REMOTE CONTROLLER(Option)	02 - 07
2-2-3 SIMPLE REMOTE CONTROLLER(Option) (With MASTER control button).....	02 - 10
2-2-4 SIMPLE REMOTE CONTROLLER(Option) (Without MASTER control button).....	02 - 13
2-2-5 GROUP REMOTE CONTROLLER(Option)	02 - 16
2-2-6 IR RECEIVER UNIT(Accessory)	02 - 20
2-2-7 EXTERNAL SWITCH CONTROLLER(Option)	02 - 22
2-2-8 COMPARISON TABLE OF CONTROLLER.....	02 - 25

3.OUTDOOR UNITS

3-1 MODEL LINE UP	03 - 01
3-2 SPECIFICATIONS	03 - 02
3-3 DIMENSIONS	03 - 03
3-4 INSTALLATION SPACE	03 - 04
3-5 REFRIGERANT CIRCUIT	03 - 05
3-6 WIRING DIAGRAM	03 - 07
3-7 CAPACITY TABLE	03 - 09
3-8 SELECTION PROCEDURE BASED ON A DESIGN	03 - 25
3-8-1 SELECTION PROCEDURE OF INDOOR UNIT AND OUTDOOR UNIT	03 - 25
3-8-2 METHOD OF CAPACITY CALCULATION	03 - 26
3-8-3 THE EXAMPLE OF CALCULATION	03 - 27
3-9 REFRIGERANT PIPING LENGTH COMPENSATION CURVE	03 - 29
3-10 OPERATION RANGE	03 - 30
3-11 SOUND LEVEL	03 - 31
3-12 ELECTRIC CHARACTERISTICS	03 - 33
3-13 SAFETY DEVICES SETTING	03 - 33

CONTENTS

4.INDOOR UNIT

4-1 MODEL LINE UP	04 - 01
4-2 FEATURE	04 - 02
4-2-1 COMPACT DUCT TYPE	04 - 02
4-2-2 LOW STATIC PRESSURE DUCT TYPE	04 - 03
4-2-3 DUCT TYPE	04 - 03
4-2-4 COMPACT CASSETTE TYPE	04 - 04
4-2-5 CASSETTE TYPE	04 - 06
4-2-6 COMPACT WALL MOUNTED TYPE	04 - 10
4-2-7 WALL MOUNTED TYPE	04 - 11
4-3 SPECIFICATIONS	04 - 12
4-3-1 COMPACT DUCT TYPE	04 - 12
4-3-2 LOW STATIC PRESSURE DUCT TYPE	04 - 13
4-3-3 DUCT TYPE	04 - 14
4-3-4 COMPACT CASSETTE TYPE	04 - 15
4-3-5 CASSETTE TYPE	04 - 16
4-3-6 COMPACT WALL MOUNTED TYPE	04 - 18
4-3-7 WALL MOUNTED TYPE.....	04 - 19
4-4 ELECTRIC CHARACTERISTICS	04 - 20
4-5 DIMENSIONS	04 - 22
4-5-1 COMPACT DUCT TYPE	04 - 22
4-5-2 LOW STATIC PRESSURE DUCT TYPE	04 - 26
4-5-3 DUCT TYPE	04 - 26
4-5-4 COMPACT CASSETTE TYPE	04 - 28
4-5-5 CASSETTE TYPE	04 - 29
4-5-6 COMPACT WALL MOUNTED TYPE	04 - 31
4-5-7 WALL MOUNTED TYPE.....	04 - 32
4-6.WIRING DIAGRAMS	04 - 33
4-6-1 COMPACT DUCT TYPE	04 - 33
4-6-2 LOW STATIC PRESSURE DUCT TYPE	04 - 36
4-6-3 DUCT TYPE	04 - 36
4-6-4 COMPACT CASSETTE TYPE	04 - 38
4-6-5 CASSETTE TYPE	04 - 39
4-6-6 COMPACT WALL MOUNTED TYPE	04 - 41
4-6-7 WALL MOUNTED TYPE.....	04 - 42
4-7 PIPING DIAGRAM	04 - 43

CONTENTS

4.INDOOR UNIT

4-8 CAPACITY TABLE (COOLING)	04 - 44
4-8-1 COMPACT DUCT TYPE	04 - 44
4-8-2 LOW STATIC PRESSURE DUCT TYPE	04 - 46
4-8-3 DUCT TYPE	04 - 47
4-8-4 COMPACT CASSETTE TYPE	04 - 48
4-8-5 CASSETTE TYPE	04 - 50
4-8-6 COMPACT WALL MOUNTED TYPE	04 - 52
4-8-7 WALL MOUNTED TYPE.....	04 - 53
4-9 CAPACITY TABLE (HEATING)	04 - 54
4-9-1 COMPACT DUCT TYPE	04 - 54
4-9-2 LOW STATIC PRESSURE DUCT TYPE	04 - 56
4-9-3 DUCT TYPE	04 - 57
4-9-4 COMPACT CASSETTE TYPE.....	04 - 58
4-9-5 CASSETTE TYPE.....	04 - 59
4-9-6 COMPACT WALL MOUNTED TYPE	04 - 61
4-9-7 WALL MOUNTED TYPE.....	04 - 62
4-10 AIR VELOCITY DISTRIBUTION	04 - 63
4-10-1 COMPACT CASSETTE TYPE	04 - 63
4-10-2 CASSETTE TYPE	04 - 66
4-10-3 COMPACT WALL MOUNTED TYPE	04 - 72
4-10-4 WALL MOUNTED TYPE	04 - 75
4-11 FAN PERFORMANCE AND AIR FLOW	04 - 78
4-11-1 FAN CURVE (COMPACT DUCT TYPE)	04 - 78
4-11-2 FAN CURVE (LOW STATIC PRESSURE DUCT TYPE)	04 - 80
4-11-3 FAN CURVE (DUCT TYPE).....	04 - 82
4-11-4 DUCT CONNECTION	04 - 86
4-12 NOISE LEVEL CURVE	04 - 89
4-12-1 COMPACT DUCT TYPE	04 - 89
4-12-2 LOW STATIC PRESSURE DUCT TYPE.....	04 - 90
4-12-3 DUCT TYPE.....	04 - 91
4-12-4 COMPACT CASSETTE TYPE	04 - 92
4-12-5 CASSETTE TYPE	04 - 93
4-12-6 COMPACT WALL MOUNTED TYPE	04 - 95
4-12-7 WALL MOUNTED TYPE	04 - 96
4-13 SAFETY DEVICE	04 - 98

CONTENTS

5.INSTALLATION

5-1 PIPING DESIGN	05 - 01
5-1-1 PIPING METHOD	05 - 01
5-1-2 LIMITATIONS	05 - 03
5-1-3 PIPE SIZE	05 - 04
5-1-4 SELECTION OF PIPE HEAT INSULATING MATERIAL	05 - 05
5-1-5 ADDITIONAL CHARGE CALCULATION	05 - 06
5-1-6 EXAMPLE OF PIPING DESIGN	05 - 07
5-2 WIRING DESIGN	05 - 13
5-2-1 WIRING SPECIFICATIONS	05 - 13
5-2-2 POWER SUPPLY & CONNECTION CORD WIRING	05 - 14
5-2-3 WIRING EXAMPLE	05 - 15
5-3 SYSTEM SETTING	05 - 16
5-3-1 SYSTEM TYPE SETTING	05 - 16
5-3-2 ADDRESS SETTING	05 - 17
5-4 FUNCTION SETTING	05 - 20
5-4-1 OUTDOOR UNIT	05 - 20
5-4-2 SWITCH FUNCTION (OUTDOOR UNIT)	05 - 22
5-4-3 INDOOR UNIT	05 - 25
5-4-4 SWITCH FUNCTION (INDOOR UNIT)	05 - 26
5-4-5 INDOOR UNIT (COMPACT WALL MOUNTED TYPE).....	05 - 30
5-4-6 SWITCH FUNCTION (COMPACT WALL MOUNTED TYPE).....	05 - 31
5-4-7 WIRED , SIMPLE REMOTE CONTROLLER	05 - 33
5-4-8 SWITCH FUNCTION (WIRED,SIMPLE REMOTE CONTROLLER)	05 - 34
5-4-9 GROUP REMOTE CONTROLLER.....	05 - 35
5-4-10 SWITCH FUNCTION (GROUP REMOTE CONTROLLER).....	05 - 35
5-5 EXTERNAL INPUT & OUTPUT	05 - 36
5-5-1 INDOOR UNIT	05 - 36
5-5-2 INDOOR UNIT (COMPACT WALL MOUNTED TYPE)	05 - 38
5-5-3 OUTDOOR UNIT	05 - 39
5-5-4 GROUP REMOTE CONTROLLER CONVERTOR	05 - 40

CONTENTS

5.INSTALLATION

5-6 INSTALLATION WORK	05 - 44
5-6-1 INSTALLATION THE OUTDOOR UNIT	05 - 44
5-6-2 INSTALLATION SPACE	05 - 45
5-6-3 PIPING CONNECTION	05 - 48
5-6-4 ELECTRICAL WIRING	05 - 59
5-6-5 DRAIN PROCESSING	05 - 62
5-6-6 DRAIN PUMP UNIT	05 - 67
5-6-7 TEST RUN	05 - 70
5-7 STANDARD ACCESSORIES	05 - 71
5-7-1 OUTDOOR UNIT	05 - 71
5-7-2 INDOOR UNIT	05 - 72
5-8 REFRIGERANT LEAKAGE CAUTION	05 - 75
5-8-1 INTRODUCTION	05 - 75
5-8-2 CHECKING CONCENTRATION LIMIT	05 - 75

6.TROUBLE SHOOTING

6-1 TROUBLE SHOOTING	06 - 01
6-1-1 OUTDOOR UNIT	06 - 01
6-1-2 INDOOR UNIT	06 - 03
6-1-3 WIRED,SIMPLE REMOTE CONTROLLER	06 - 04
6-1-4 GROUP REMOTE CONTROLLER	06 - 05
6-1-5 CASES SUCH AS THESE ARE NORMAL	06 - 07

7.OPTIONAL PARTS

7-1 SEPARATION TUBE	07 - 01
7-2 HEADER	07 - 02
7-3 EV KIT.....	07 - 03
7-4 CONTROLLER	07 - 04
7-5 OTHERS	07 - 06

AIRSTAGE™

J SERIES

1 . GENERAL INFORMATION

1-1. FEATURES OF SYSTEM

Caring for people and surroundings 15.2kW high-performance air conditioning system. The compact VRF system provides economical and comfortable air conditioning for wide range of applications from living space to business space. Compact VRF system for use in homes, shops, offices and abroad range of other applications.

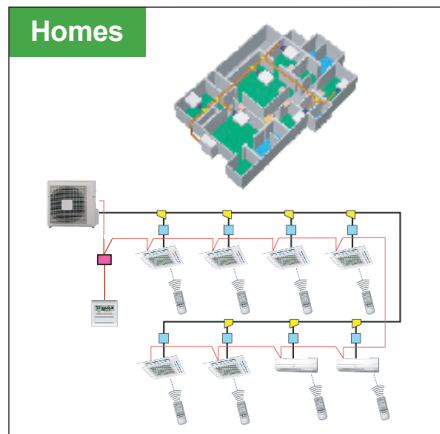

Homes need individual air conditioning control for specific rooms that can also be easily switched to stand-by mode if the occupants have to go out at short notice.

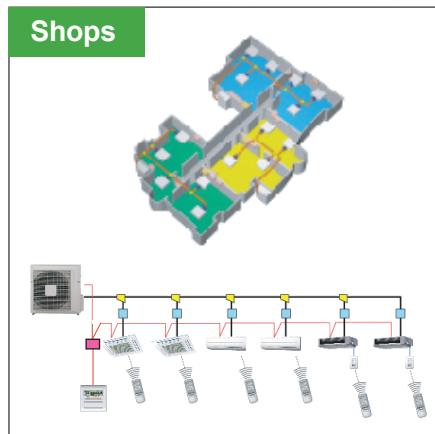

As shop premises are regularly upgraded and the operating conditions for each can vary so much, large-scale air conditioning management is very difficult. Consequently, a VRF air conditioning system matched to each shop is an ideal solution.

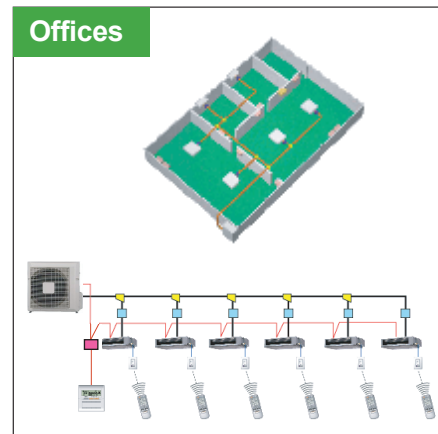

The spaces within office premises can all have different air conditioning requirements. Energy saving and economic operation are major issues and what is needed is air conditioning system which can be accurately matched to each space and centrally controlled.

1-1-1. FEATURE

■ LONG PIPING LENGTH

The maximum piping length is 70m, and can cope with a wide range of applications from homes to offices.

Height difference between outdoor unit and indoor units : 30m max.

Actual pipe length : 70m max.

Total pipe length : 115m max.

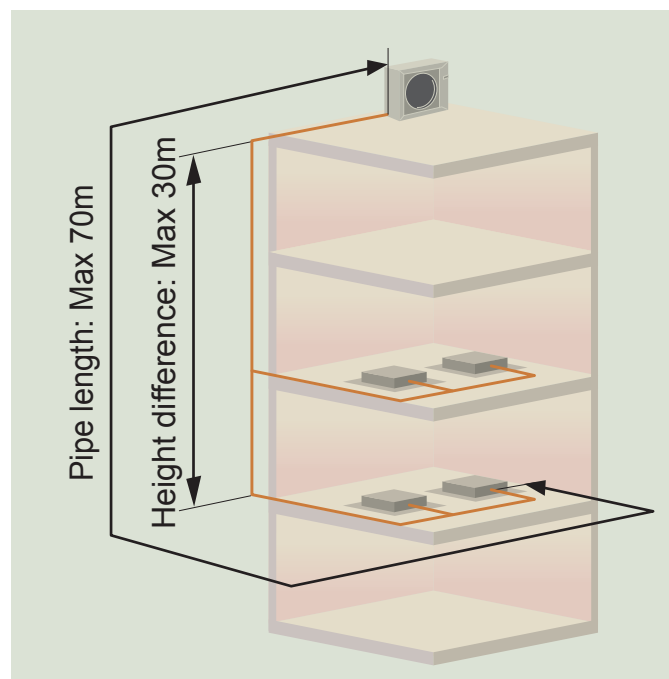

■ ECONOMICAL HIGH-EFFICIENCY OPERATING SYSTEM

- Powerful operation with little electricity
Cooling/heating average COP 3.3 high COP value attained.

Cooling COP	3.20
Heating COP	3.40

*"COP" is the coefficient of performance
(= rated capacity (kW) ÷ Input power (kW)).

- Uses a high-performance DC inverter scroll compressor whose capacity can be varied according to the load during cooling and heating.

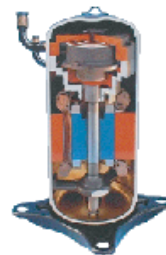

■ HIGH-CAPACITY CONNECTION POSSIBLE

One outdoor unit can connect to up to 8 indoor units. Connectable capacity is 150% of the outdoor unit rating and can cope with diverse operating modes.

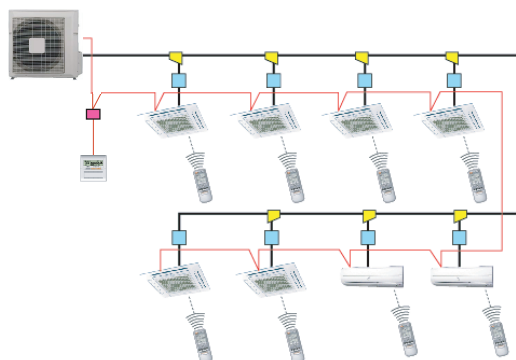

■ OPERATING OUTSIDE AIR TEMPERATURE RANGE

Outdoor unit operates over an ambient temperature range of -5°C to 43°C for cooling and -20°C to 21°C for heating.

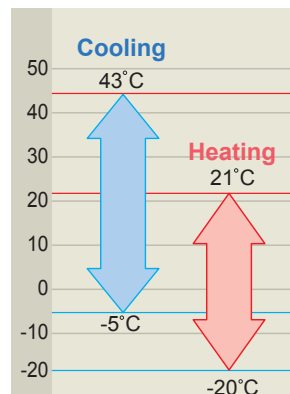

■ SURROUNDINGS CONSCIOUS

Advancements in refrigerant technology have given us the zero ozone depleting R410A refrigerant. Used in our products, this refrigerant provides higher efficiency operation, while reducing the impact on our surroundings.

■ LIGHTWEIGHT AND COMPACT DESIGN

Low, compact body is hidden behind a fence that does not blot the landscape. Its physical appearance under the window is also refreshing.

● Dimensions

H900 x W900 x D370mm

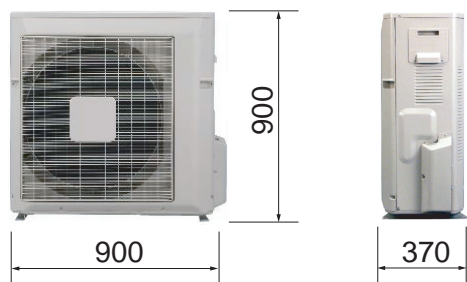

(Unit: mm)

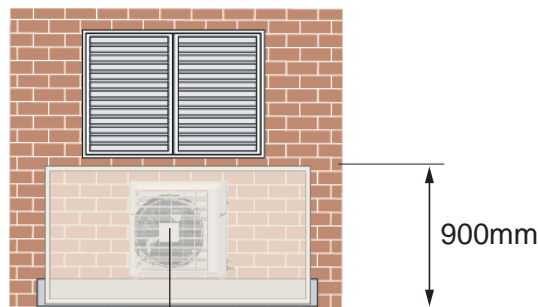

Window view is also made pleasant by also hiding at the wall under the window.

● Suppressed height and lightweight design

 120kg Fujitsu General conventional type 15.2kW single type	▶	 97kg AIRSTAGE J SERIES 15.2kW VRF
--	---	---

■ NOISE REDUCTION

Newly designed larger fan and double casing bell mouth construction reduce noise emissions.

Large fan

Low-speed design suppresses noise by using a larger fan.

Double casing bell mouth

Double casing bell mouth helps to reduce noise.

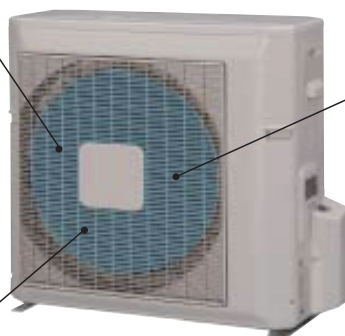

■ BLUE FIN HEAT EXCHANGER MOUNTED

Corrosion-resistance of the heat exchanger even in coastal areas has been improved by blue fin treatment of the outdoor unit heat exchanger.

Blue fin heat exchanger

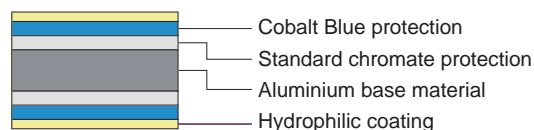

*Cobalt blue protection (Blue Fin) is a standard specification of AJ*A54LCLR, AJ*A54JCLR.

■ FLEXIBILITY OF LAYOUT

• Maximum 8 indoor units could be connected

One outdoor unit can control individually up to 8 indoor units of different type and capacity.

The number of connectable indoor unit	capacity ratio of outdoor unit
1 to 8	50 to 150%

※ Actual capacity of each indoor units might be limited, if the total operating capacity of indoor units exceeds the maximum system (outdoor) capacity.

• Various connectable indoor unit

Various combinations of indoor unit type and capacity 7 types 30 models ranging from 2.15kW to 14.1kW.

Type		Compact Cassette	Cassette	Compact Duct	Low Static Pressure Duct	Duct	Compact Wall mounted	Wall mounted
Capacity (kW)	Model code							
14.1	54		●					
12.7	45		●			●		
10.5	36		●			●		
8.80	30		●		●	●		●
7.05	25		●		●	●		
6.90	24							●
6.00	22			●				
5.70	20		●					
5.30	18	●		●				●
4.00	14	●		●			●	
3.60	12	●		●			●	
2.80	9	●		●			●	
2.15	7	●		●			●	

■ CENTRALIZED CONTROL

Centralized control of up to 8 indoor units.

Central or individual control with weekly timer can be realized.

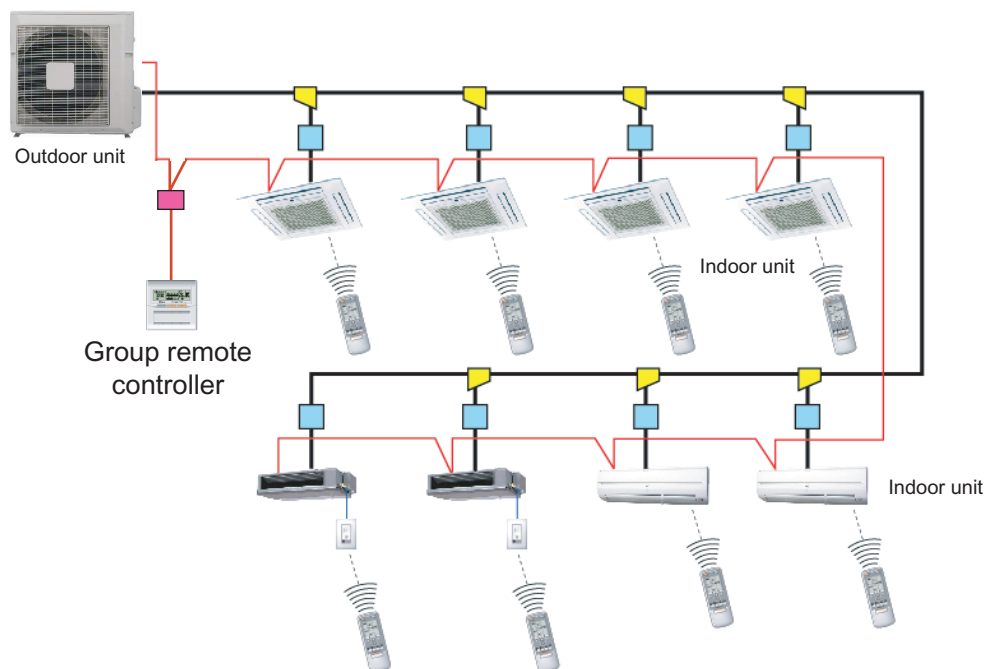

■ SYSTEM ADDRESSING

During installation work, the system addressing can be performed using the wireless remote controller, thus eliminating manual switch setting.

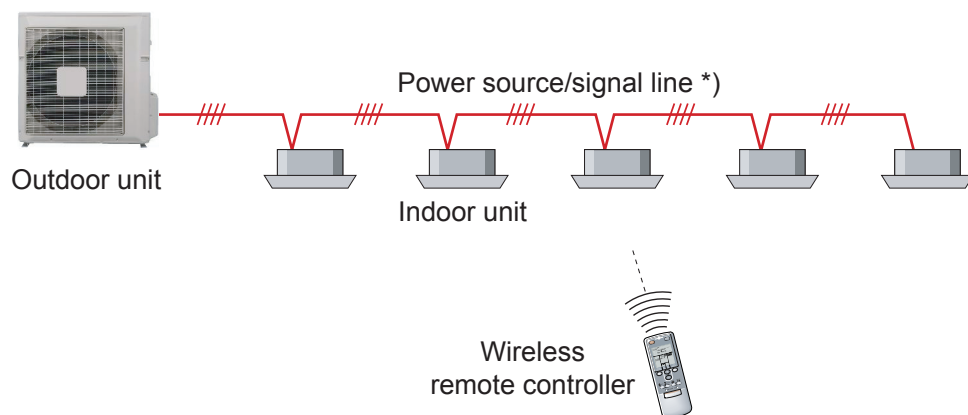

*) 3 wires : for power source and signal line ; 1 wire : for ground.

■ FLEXIBLE PIPING

Selectable variation by using separation tube and header.

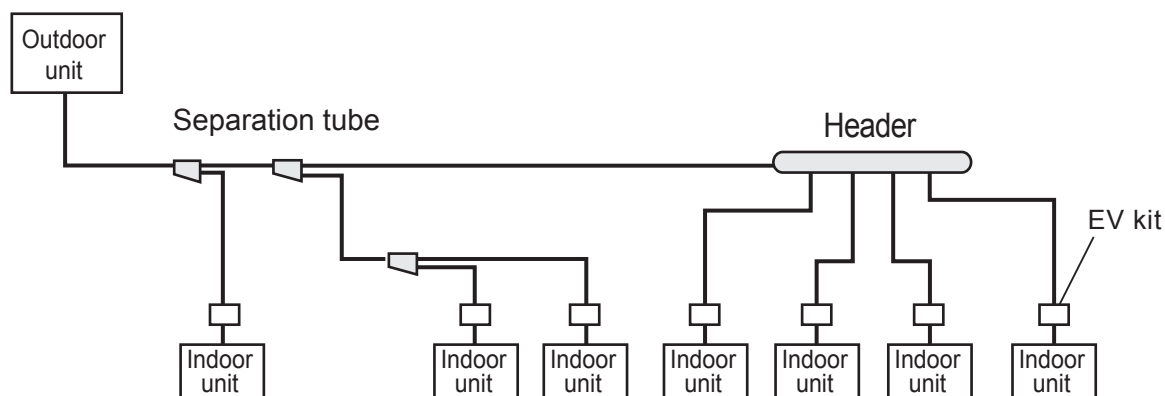

1-2. MODEL LINE UP

■ OUTDOOR UNIT

TYPE	CAPACITY	MODEL	The number of connectable indoor unit
Heat pump type	15.2 kW	AJ *A54LCLR AO*54UJBMR	1 to 8
Cooling only type	15.2 kW	AJ *A54JCLR AO*54FJBMR	1 to 8

Refrigerant : R410A





• Heat pump type
AJ *A54L
AO*54U



• Cooling only type
AJ *A54J
AO*54F











■ REMOTE CONTROLLER

Individual Control			Central control
Accessory	Optional	Optional	Optional
Wireless Remote Controller	Wired Remote Controller	Simple Remote Controller	Group Remote Controller
			

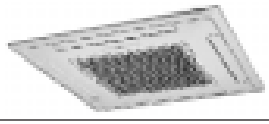
INDOOR UNIT

7 types, 30 models ranging from 2.15kW to 14.1kW.

Type		Compact Cassette	Cassette	Compact Duct	Low Static Pressure Duct	Duct	Compact Wall mounted	Wall mounted
Capacity (kW)	Model code							
14.1	54		●					
12.7	45		●			●		
10.5	36		●			●		
8.80	30		●		●	●		●
7.05	25		●		●	●		
6.90	24							●
6.00	22			●				
5.70	20		●					
5.30	18	●		●				●
4.00	14	●		●			●	
3.60	12	●		●			●	
2.80	9	●		●			●	
2.15	7	●		●			●	

<p>● Compact Cassette TYPE</p> <p>AU 7 AU 9 AU12 AU14 AU18</p> 	<p>● Cassette TYPE</p> <p>AU20 <i>Slim Type</i> AU25 AU30</p> <p>AU36 AU45 AU54</p>  	<p>● Compact Duct TYPE</p> <p>AR 7 AR 9</p>  <p>AR12 AR14 AR18 AR22</p> 
<p>● Low Static Pressure Duct TYPE</p> <p>ARXB25 <i>Silent model</i> ARXB30</p> 	<p>● Duct TYPE</p> <p>AR25 AR30 AR36 AR45</p> 	<p>● Compact Wall Mounted TYPE</p> <p>AS 7 AS 9 AS12 AS14</p> 
<p>● Wall Mounted TYPE</p> <p>AS18 AS24 AS30</p> 		

AIRSTAGE™

J SERIES

2 . CONTROL SYSTEM

2-1. CONTROL SYSTEM

2-1-1. LINE UP OF CONTROLLERS

Control system that totally controls a pleasant air conditioning environment

Five types of controllers are available to meet the varied needs of the building and the user. Tighter control over the air conditioned environment can be achieved by combining: central remote controller which can operate all the indoor units at the same time, a wired remote controller with a weekly or daily schedule, a wireless remote controller and a simple remote controller.

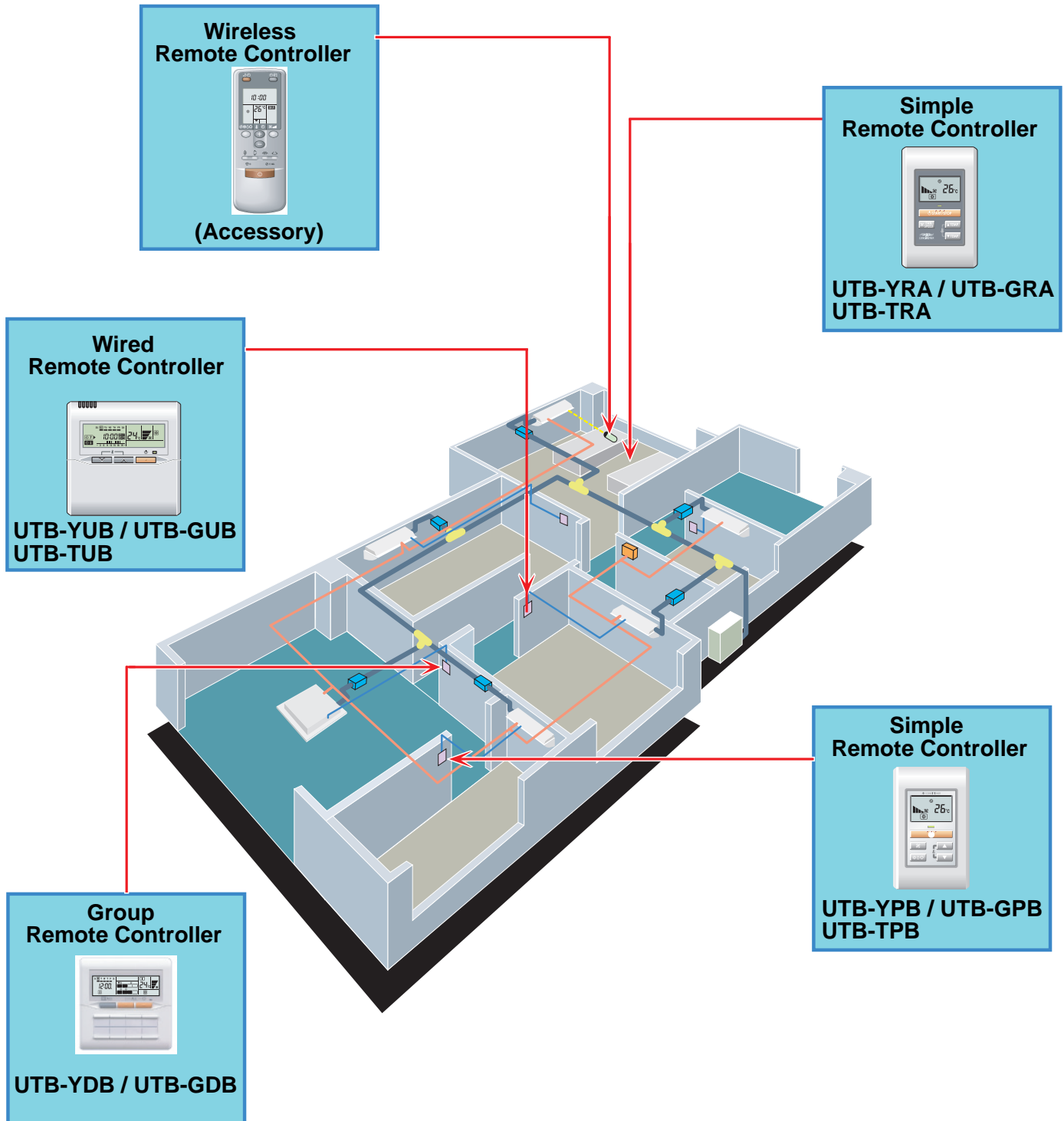

2-1-2. SYSTEM CONFIGURATION

- Wiring system which spans the power source and signal lines improves reliability.

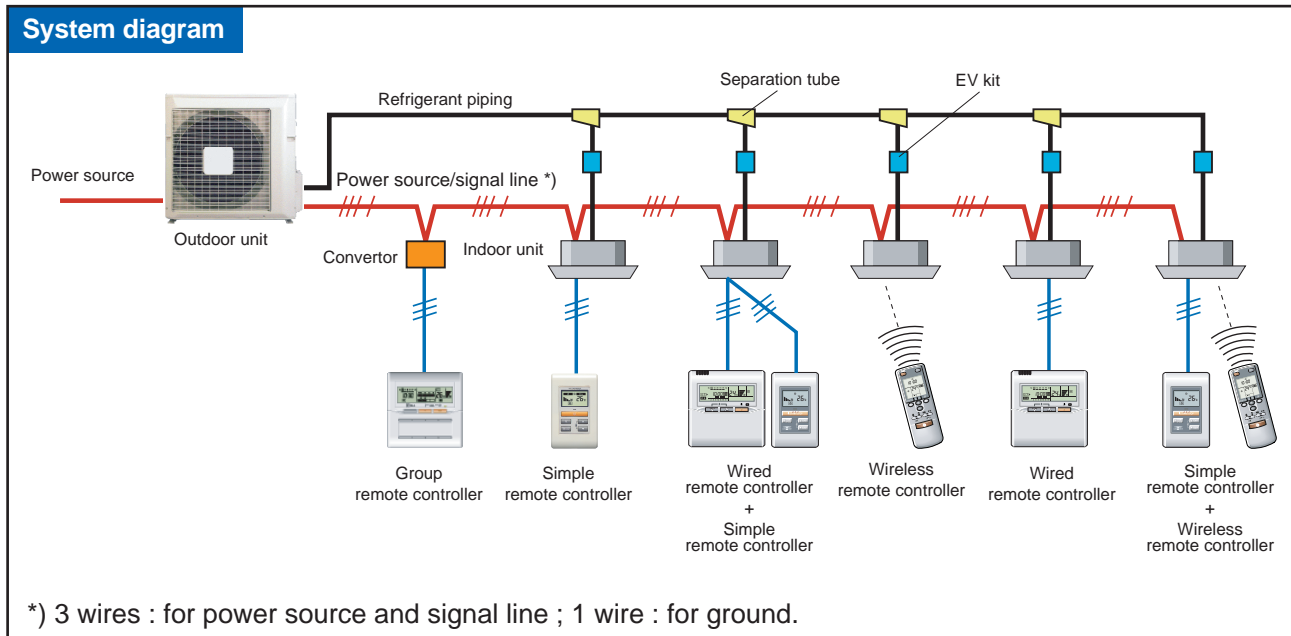

2-1-3. FEATURES OF CONTROL SYSTEM

1. FGL system can install by wiring from equipment to equipment in the wiring work.
2. This wiring system can shorten the wiring length and makes the work easily.
3. Address setting during construction work can be performed using the accessory wireless remote controller. Therefore, switch setting at each indoor unit like in the past is unnecessary.
4. 2 remote controller are connectable for 1 indoor unit.

2-2. CONTROL UNITS

The following types of controllers are available with the J series VRF system.

- **Wireless remote controller**
- **Wired remote controller**
- **Simple remote controller**
- **Group remote controller**

Individual Control

Wireless Remote Controller (Accessory)



Wired Remote Controller (Option)

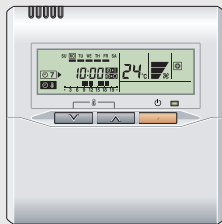

Simple Remote Controller (Option)



Central Control Group Remote Controller (Option)

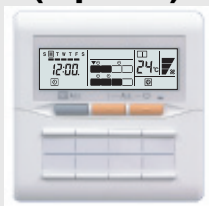

2-2-1. WIRELESS REMOTE CONTROLLER (Accessory)

Wireless remote controller is an accessory of all indoor units.

■ FEATURES



- * Four kinds of timer setup (ON / OFF / PROGRAM / SLEEP) are possible.
- * Four kinds of timers. Easy operation.
- * Can be used jointly with wired remote controllers.
- * Easy to change transmission code (4 patterns) by button operation.

● Built-in timers

Select from four different timer programs (On/Off/Program/Sleep).

● Program timer

The program timer operates the ON and OFF timer once within a 24 hour period.

● Sleep timer

The sleep timer function automatically corrects the temperature thermostat setting according to the time setting to prevent excessive cooling and heating while sleeping.

Cooling operation/dry operation

When the sleep timer is set, the set temperature automatically rises 1°C every hour. The set temperature can rise up to a maximum of 2°C.

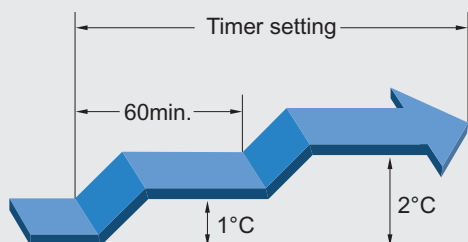

Heating operation

When the sleep timer is set, the set temperature automatically drops 1°C every 30 minutes. The set temperature can drop to a maximum of 4°C.

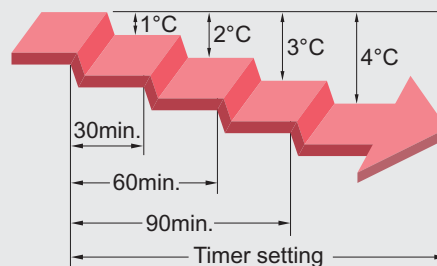

● Easy installation and operation

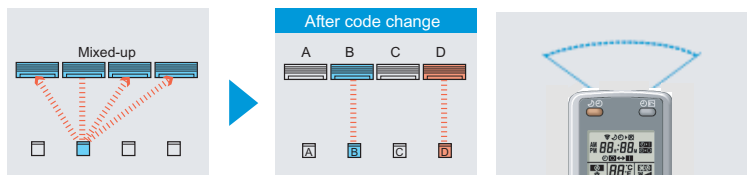

- Code selector switch eliminates unit being wrongly switched. (Up to 4 codes can be set.)

- Wide and precise transmitting range.

● System addressing

- During installation work, system addressing can be performed using the wireless remote controller, thus eliminating manual switch setting.

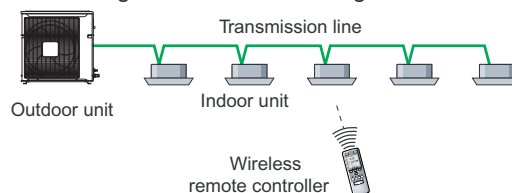

Note : Timer setting from a wireless remote controller becomes invalid, if the indoor unit is connected with a wired or a simple remote controller.

FUNCTIONS

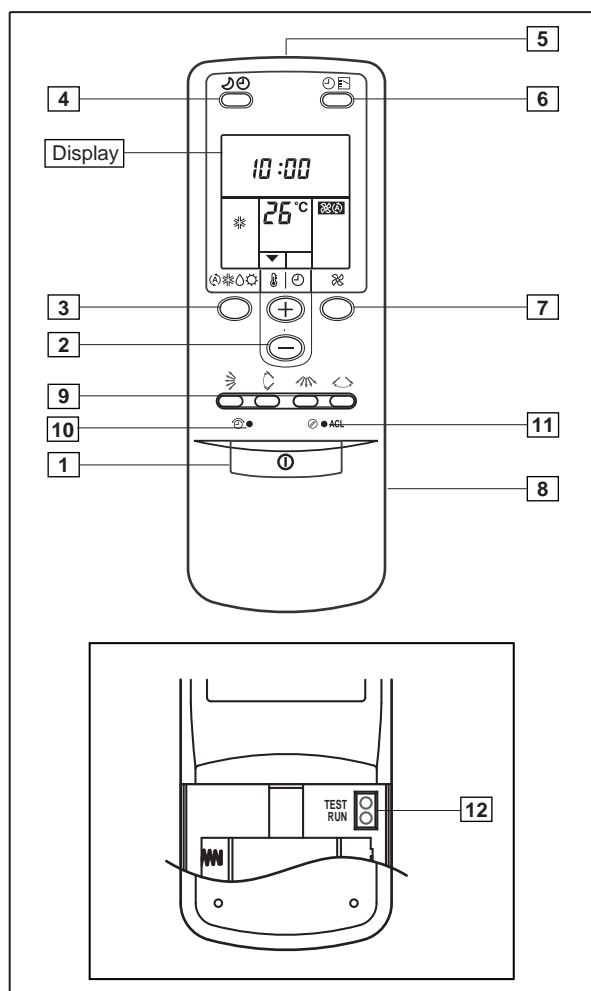

- 1** START/STOP button
Pressed to start and stop operation
- 2** Set temp./Set time buttons/Set remote controller custom code buttons
Sets the indoor temp.(From 18-30°C [Cool] , 16-30°C [Heat])
Sets the current time and on-off time
Sets R.C. custom code
- 3** Master control button/Code change
Selects the operating mode (AUTO Ⓐ ※1, COOL ❄️, DRY ⏸️, FAN ❄️ ※1, HEAT 🔥 ※2).
Start/end R.C. custom code change. (Max. 4 types)
- 4** Sleep timer button
Pressed to select sleep timer.
- 5** Signal transmitter
- 6** Timer button
Pressed to select the timer mode. (OFF TIMER, ON TIMER, PROGRAM TIMER, TIMER RESET)
- 7** Fan control button
Selects the fan speed (AUTO Ⓐ, HIGH 📊, MED 📊, LOW 📊).
- 8** Battery compartment lid
- 9** Air flow direction button
Used to set the desired air flow direction & swing function.
- 10** Time adjust button
Sets the current time.
- 11** ACL button
Used when replacing batteries or change the code.
- 12** Test run button
Used when testing the air conditioner after installation.

Display panel

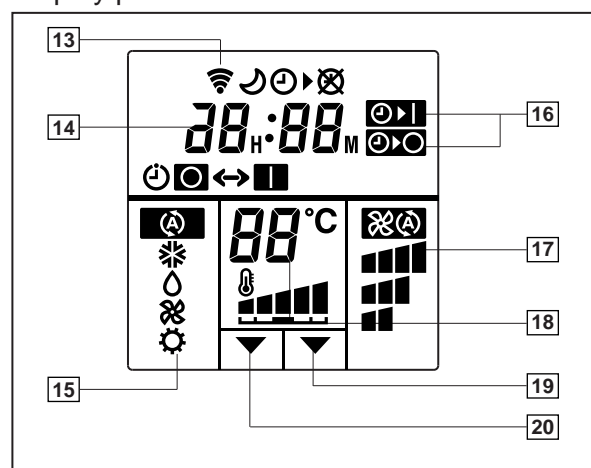

- 13** Transmit indicator
- 14** Clock display
- 15** Master control display
- 16** Timer mode display
- 17** Fan speed display
- 18** Set temperature display
- 19** Timer set indicator
- 20** Temperature set indicator

NOTE

- ※ 1 : "AUTO Ⓐ" and "FAN ❄️" cannot be selected for "HEAT PUMP TYPE"
- ※ 2 : "HEAT 🔥" cannot be selected for "COOLING ONLY TYPE"

■ SPECIFICATION

Model name	-
Size [H x W x D (mm)]	158 x 56 x 20
Weight (g)	70

■ SYSTEM DIAGRAM

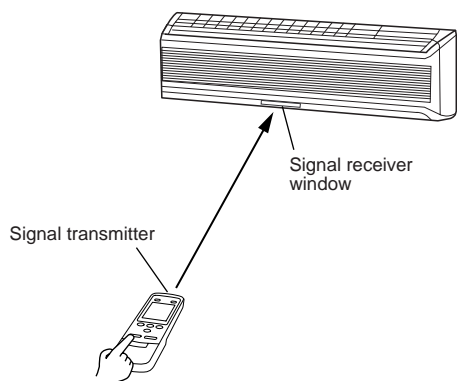

- * Control signal might not be recognized in following cases:
 - (i) A curtain or a wall, etc. exists between transmitter and receiver.
 - (ii) There is an instant-start type (inverter type, etc.) fluorescent lamp in the room.

- * Air conditioner might not work correctly when strong light hits the signal receiver window. Shut off the direct sunlight and also make illuminator far away from the receiver window.

■ PACKING LIST

Name	Quantity	Application
Remote controller	1	Use for air conditioner operation
Remote controller holder	1	Use as remote controller holder
Tapping screw	2	For remote controller holder installation
Battery [1.5V (R03 / LR03 / AAA) x 2]	2	For remote controller

■ DIMENSION

[Unit : mm]

● Holder

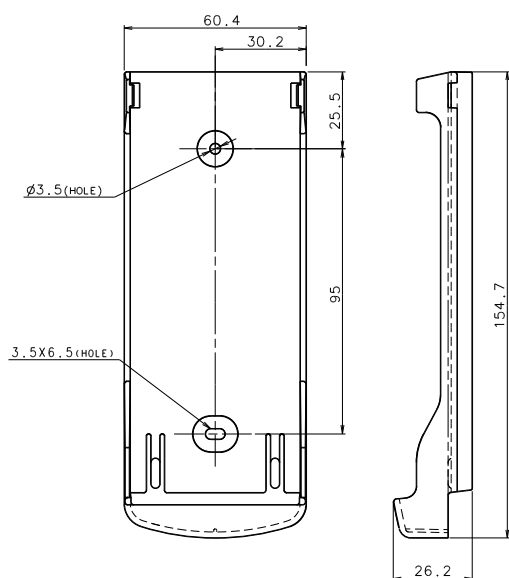

Front view

Side view

Bottom view

● Controller

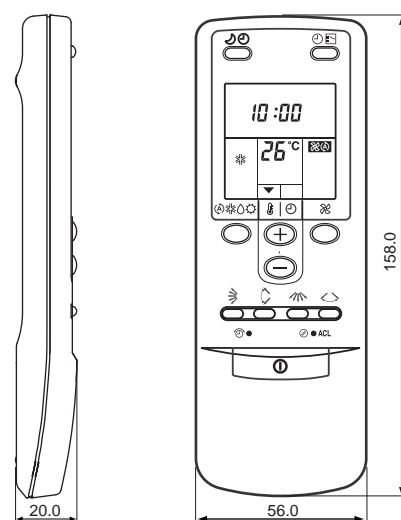

Side view

Front view

2-2-2.WIRED REMOTE CONTROLLER (Option)

Model : UTB - *UB (Market region Y or G or T)

FEATURES

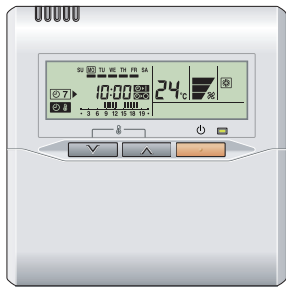

- * Various timer setup (ON / OFF / WEEKLY) are possible.
- * Equipped with weekly timer as standard function. (2 times Start / Stop per day for a week)
- * When setting up a timer, operation mode and a temperature setup can be changed.
- * When a failure occurs, the error code is displayed. (Maximum of 16)
- * Error indication. (A maximum of 16 error histories are memorizable.)
- * Easy installation with a slim shape with no bulge in the back.
- * At the time of heating operation, A room temperature setup of a low temperature is possible. (10°C~)
- * The room temperature can be controlled by being detective the temperature accurately with Built-in thermo sensor.

Powerful features and compact size



Accurate and comfortable

Indoor temperature can be detected accurately by the inclusion of a thermo sensor in the body of the wired controller.

Our system can correspond to various scenes.

This new wired remote controller and the optional remote sensor allows flexibility in sensor location, suitable for all requirements.

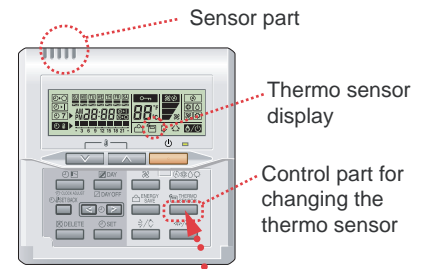

Built-in timers

Weekly timer

Possible to set ON/OFF time to operate twice each day of the week.

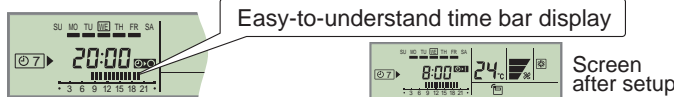

Setup screen example
(Set to Wednesday: 8:00 to 20:00.)

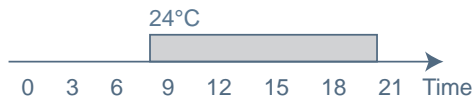

Setback timer

Possible to set temperature for two time spans and for each day of the week.

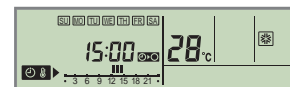

Setup screen example
(Set from Sunday to Saturday: 12:00 to 15:00, 28 °C.)

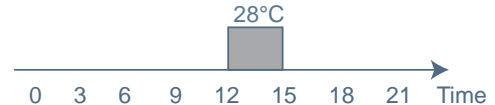

At "Weekly timer" + "Set back timer" setup

24°C → 28°C → 24°C

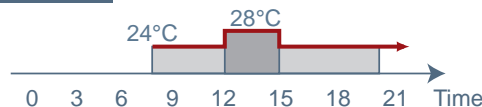

Easy-to-understand operation

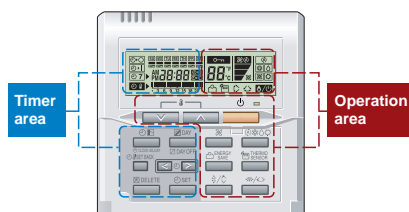

[Variable timer control]

The operation/display sections are zoned according to time and operation, enabling variable programming to match application.

Simple installation

Components are compatible with standard switch boxes. Flat back construction allows equipment to be installed wherever it is needed.

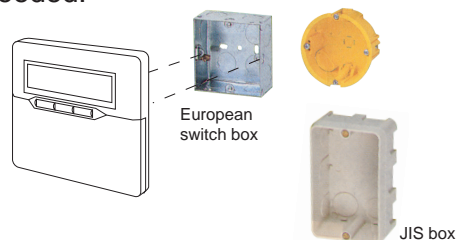

FUNCTIONS

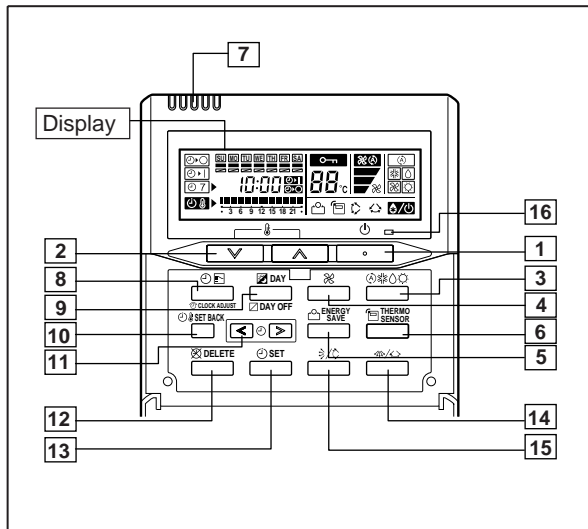

Display panel

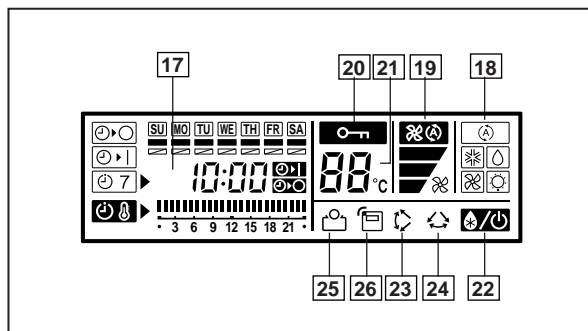

SPECIFICATIONS

Model name	UTB - * UB
Size [H x W x D (mm)]	120 x 120 x 17
Weight (g)	160

- 1 **START/STOP button**
Pressed to start and stop operation.
- 2 **Set Temperature button**
Selects the setting temperature.(18-30°C[COOL], 10-30°C[HEAT])
- 3 **Master control button**
Selects the operating mode (AUTO Ⓐ ※1, COOL ❄️, DRY ∆, FAN ❄️ ※1, HEAT 🔥 ※2).
- 4 **Fan control button**
Selects the fan speed (AUTO ⚙️, HIGH 🌬️, MED 🌬️, LOW 🌬️).
- 5 **Energy save button**
- 6 **Thermo sensor button**
Selects whether the room temperature is detected at the indoor unit (remote sensor) or the remote controller.
- 7 **Built-in thermo sensor**
Detect room temperature.
- 8 **Timer mode (CLOCK ADJUST) button**
Selects the timer mode (OFF TIMER, ON TIMER, WEEKLY TIMER)
Set the current time.
- 9 **Day (DAY OFF) button**
Temporarily cancels of one day timer.
- 10 **Set back button**
Pressed select the set back timer.
- 11 **Set time button**
Pressed to select the set back timer.
- 12 **Delete button**
The schedule of a weekly timer is deleted.
- 13 **Set button**
Sets the date, hour, minute and on-off time.
- 14 **Horizontal air flow direction and swing button**
Push for two seconds to change the swing mode.
- 15 **Vertical air flow direction and swing button**
Push for two seconds to change the swing mode
- 16 **Operation lamp**
Lights during operation and when the timer is on.
- 17 **Timer and clock display**
- 18 **Operation mode display**
- 19 **Fan speed display**
- 20 **Operation lock display**
- 21 **Temperature display**
Displayed temperature is set temperature.
- 22 **Defrost display**
Indicates during the oil recovery and defrosting operation.
- 23 **Vertical swing display**
- 24 **Horizontal swing display**
- 25 **Energy save display**
- 26 **Thermo sensor display**

NOTE

- ※ 1 : "AUTO Ⓐ" and "FAN ❄️" cannot be selected for "HEAT PUMP TYPE"
- ※ 2 : "HEAT 🔥" cannot be selected for "COOLING ONLY TYPE"

SYSTEM DIAGRAM

● 1 remote controller

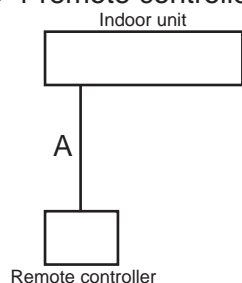

● 2 remote controllers

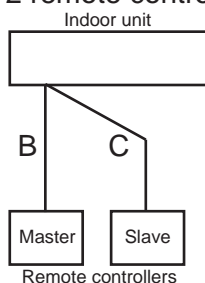

A, B, C : Remote controller cable. Refer to 5-2-1 for detail specification.
 $A \leq 500\text{m}$; $B+C \leq 500\text{m}$

PACKING LIST

Name	Quantity	Application
Wired remote controller	1	
Remote controller cable *1)	10m	For connecting the remote controller (Exclude some models)
Tapping screw (M4 x 16mm)	2	For installing the remote controller
Binder	1	For remote controller and remote controller cable binding
Cord clamper	1	For installing the remote controller cable to the indoor unit
Tapping screw (M4 x 14mm)	1	For installing the remote controller cable to the indoor unit

* 1) If necessary, use shielded cable (Field supply) in accordance with the standard of the country.

DIMENSION

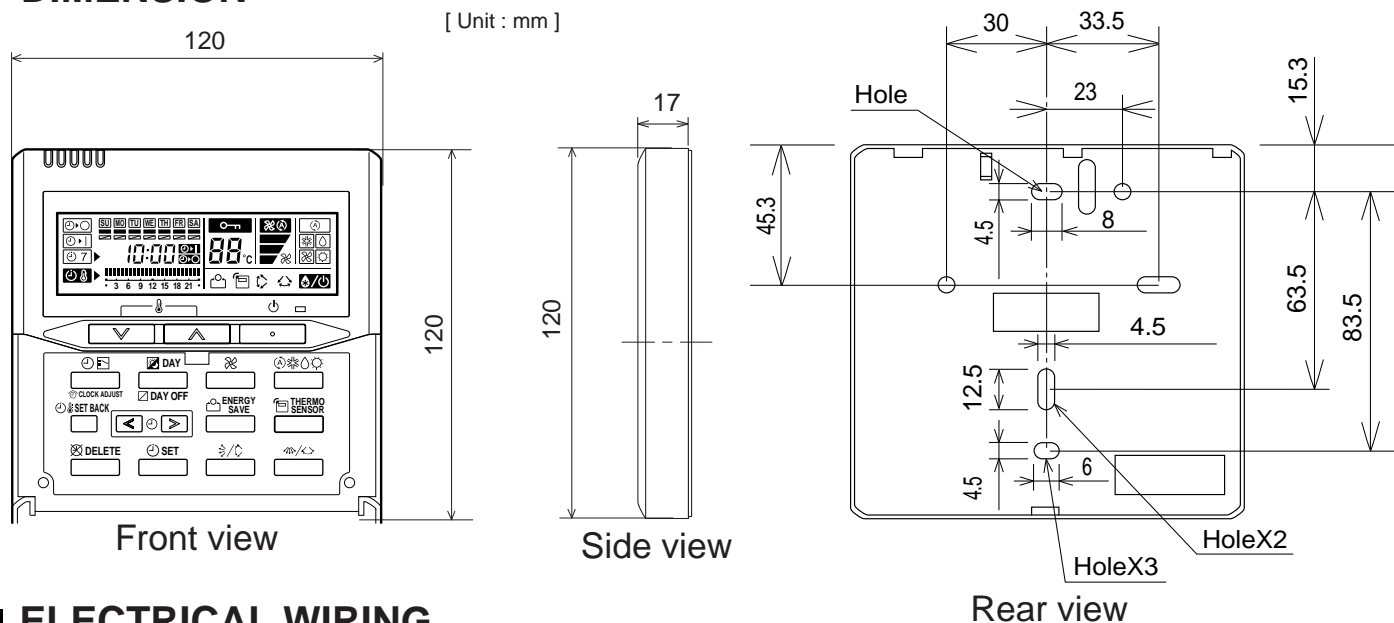

ELECTRICAL WIRING

● 1 remote controller

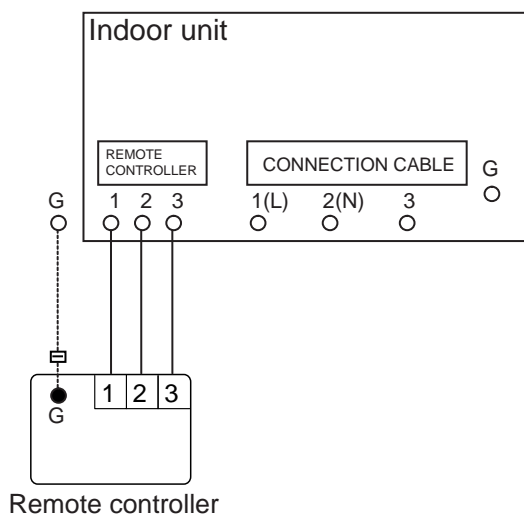

● 2 remote controllers

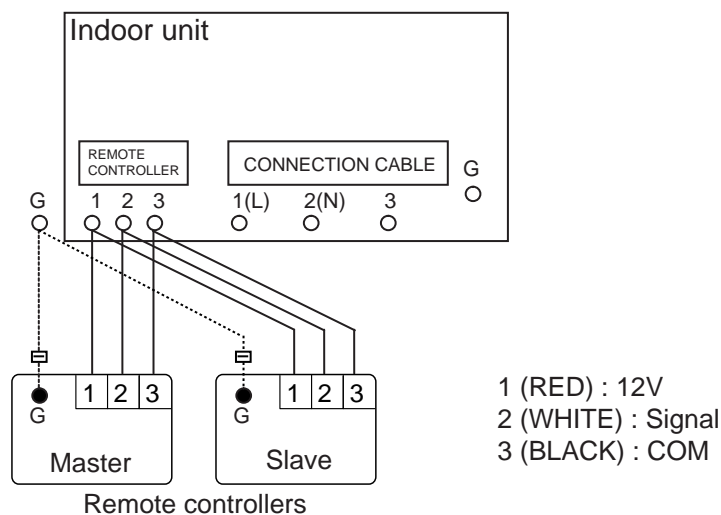

2-2-3.SIMPLE REMOTE CONTROLLER (Option) (With MASTER control button)

Model : UTB - *PB (Market region Y or G or T)

■ FEATURES



- * Easy operation.
- * Built-in Back ground Light function.
- * Easy installation with a slim shape with no bulge in the back.
- * Error indication.(A maximum of 16 error histories are memorizable.)
- * Can be installed onto SW-BOX. (applies to European and other country's standard)

● User-friendly operation

- * Provides access to basic operations, such as Start / Stop, Fan control, master control switching, and temperature setting.
- * A large Start / Stop button is provided in the centre of the remote controller unit for easy operation.
- * Following an error display, diagnostics can be carried out on the controller.

● Back ground light

- * Backlight enables easy operation in a darkened room.
- * Backlight activates during all button operations, and lasts 10 seconds in operating mode and 5 seconds in stop mode after a button is pressed.



● Simple installation

- * Can be mounted on the European mounting Box (installation dimension: 60mm) or the JIS Built-in Box (installation dimension: 83.5mm).

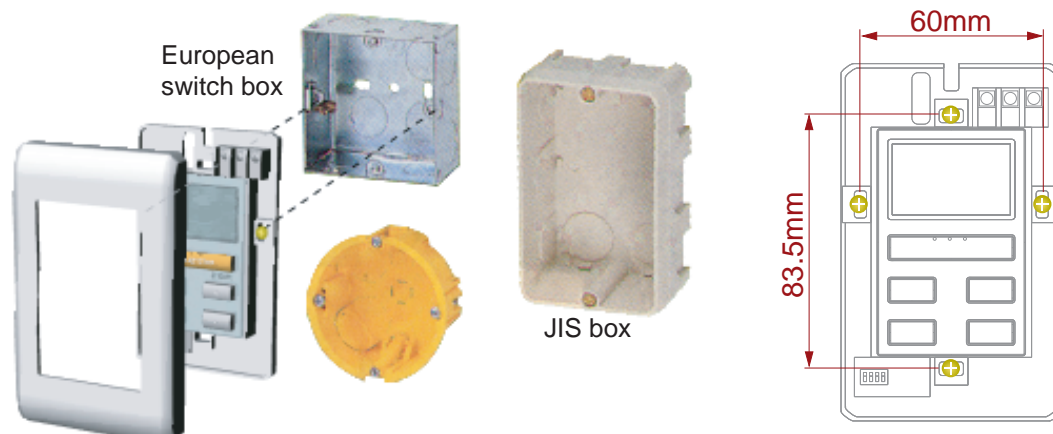

FUNCTIONS

CONTROL SYSTEM

CONTROL SYSTEM

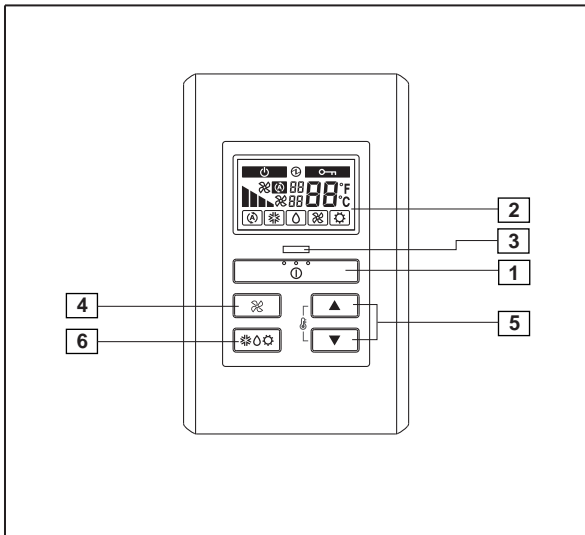

- 1** START/STOP button
Pressed to start and stop operation
- 2** Display background light
Lights during operation.
- 3** Operation lamp
Lights during operation.
- 4** Fan control button
Selects the fan speed (AUTO , HIGH , MED , LOW).
- 5** Set temperature button
Selects the setting temperature. (18-30°C[COOL], 16-30°C[HEAT])
- 6** Master control button
Selects the operating mode (AUTO *1, COOL *1, DRY *1, FAN *1, HEAT *2).
- 7** Standby display
Indicates during the oil recovery and defrosting operation.
- 8** Power source display
Indicates the main power ON.
- 9** Central control display
Indicates when function is locked from central remote controller or PC controller.

Display panel

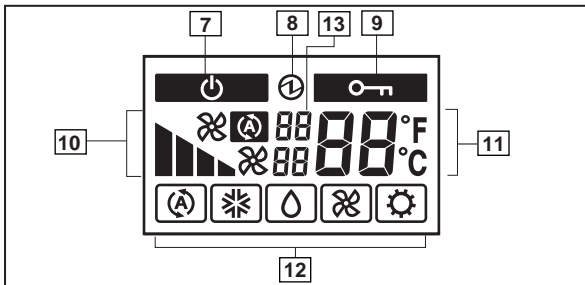

- 10** Fan speed display
- 11** Set temperature
Indicates Error history number. *4
Indicates Indoor unit address. *5
- 12** Operation mode display
- 13** (Upper) Indicates the error code *3 *4 / the refrigerant system address. *5
(Lower) Indicates the remote controller address. *3 *4 *5
*3) during self Diagnosis mode.
*4) during Error code history display mode.
*5) during address display mode.

NOTE

- ※ 1 : "AUTO " and "FAN " cannot be selected for "HEAT PUMP TYPE"
- ※ 2 : "HEAT " cannot be selected for "COOLING ONLY TYPE"

SPECIFICATIONS

Model name	UTB - *PB
Size [H x W x D (mm)]	120 x 75 x 14
Weight (g)	90

SYSTEM DIAGRAM

- 1 remote controller
- 2 remote controllers

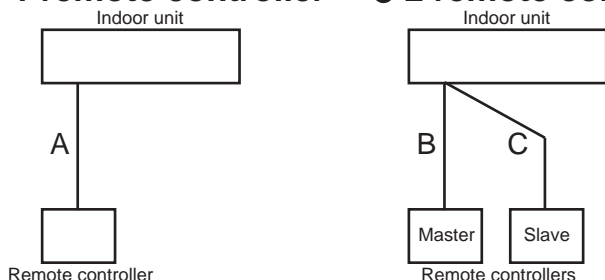

A, B, C : Remote controller cable. Refer to 5-2-1 for detail specifications.
A ≤ 500m ; B+C ≤ 500m

PACKING LIST

Name	Quantity	Application
Simple remote controller	1	
Remote controller cable *6)	10m	For connecting the remote controller (Exclude some models)
Tapping screw(M4x16mm)	2	For installing the remote controller
Binder	1	For remote controller and remote controller cable binding

*6) If necessary, use shielded cable (Field supply) in accordance with the standard of the country.

DIMENSION

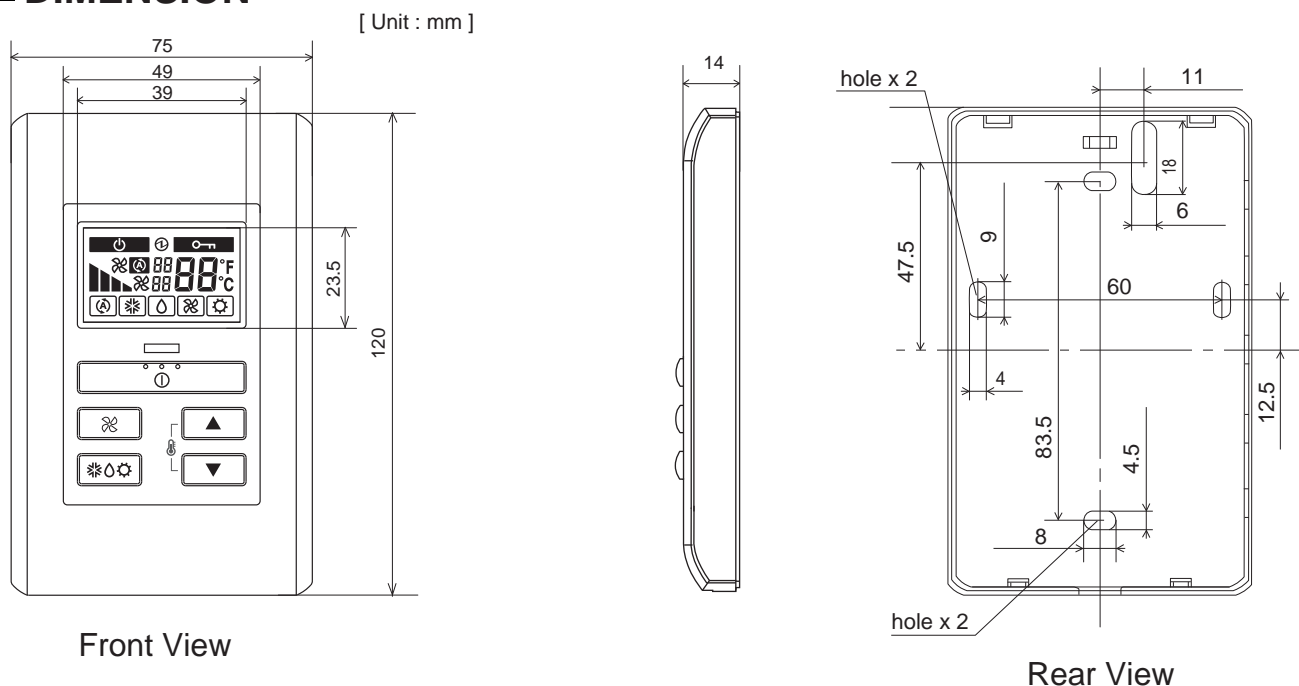

Front View

Rear View

ELECTRICAL WIRING

● 1 remote controller

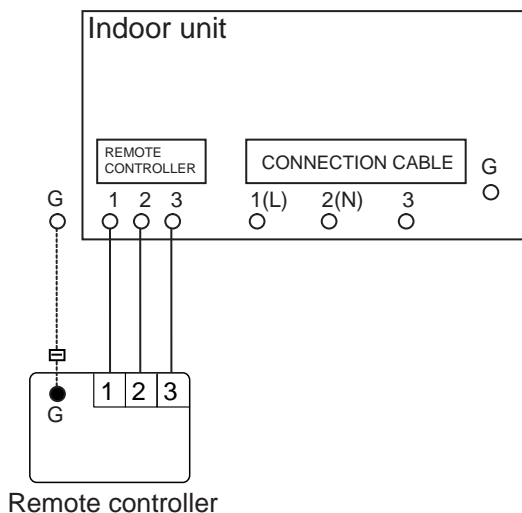

● 2 remote controllers

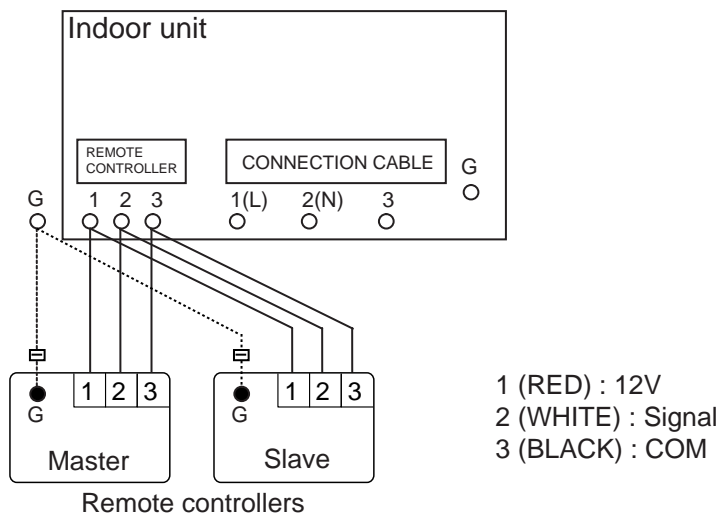

2-2-4.SIMPLE REMOTE CONTROLLER (Option)(Without MASTER control button)

Model : UTB - *RA (Market region Y or G or T)

A part of the function is limited. It is recommended to use it together with other type controller.

■ FEATURES



- * Easy operation.
- * Built-in Back Light function.
- * Easy installation with a slim shape with no bulge in the back.
- * Error indication.(A maximum of 16 error histories are memorizable.)
- * Can be installed onto SW-BOX. (applies to European and other country's standard)
- * Concentrates on the basic operations such as On/Off, Fan Control, and Temperature Setting.

● User-friendly operation

- * Provides access to basic operations, such as Start / Stop, Fan Control, and Temperature Setting.
- * A large Start / Stop button is provided in the centre of the remote controller unit for easy operation.
- * Following an error display, diagnostics can be carried out on the controller.

● Back ground light

- * Backlight enables easy operation in a darkened room.
- * Backlight activates during all button operations, and lasts 10 seconds in operating mode and 5 seconds in stop mode after a button is pressed.



● Simple installation

- * Can be mounted on the European mounting Box (installation dimension: 60mm) or the JIS Built-in Box (installation dimension: 83.5mm).

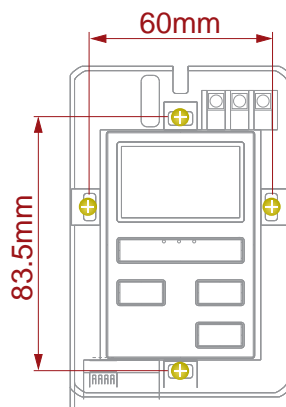
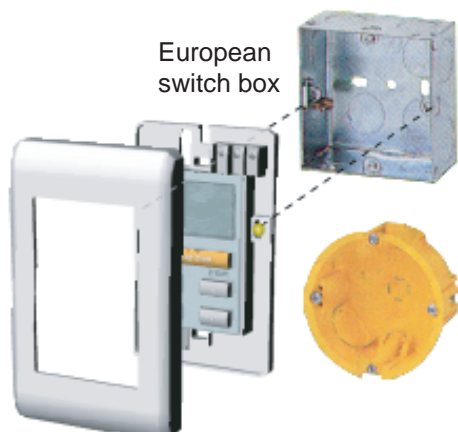

FUNCTIONS

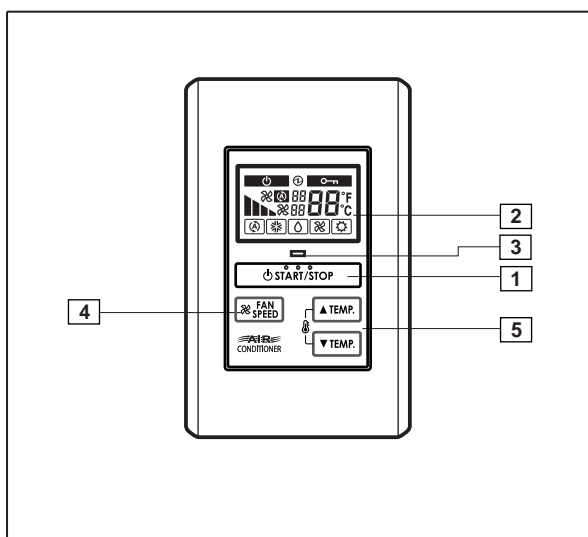

Display panel

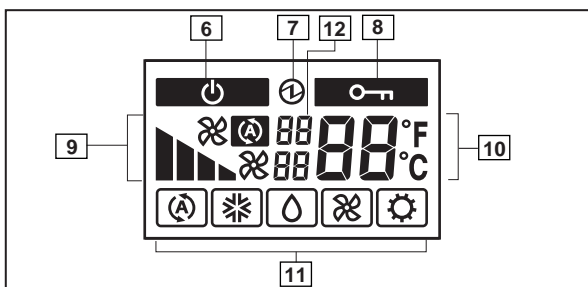

- 1 START/STOP button
Pressed to start and stop operation
- 2 Display background light
Lights during operation.
- 3 Operation lamp
Lights during operation.
- 4 Fan control button
Selects the fan speed (AUTO, HIGH, MED, LOW).
- 5 Set temperature button
Selects the setting temperature. (18-30°C[COOL], 16-30°C[HEAT])
- 6 Standby display
Indicates during the oil recovery and defrosting operation.
- 7 Power source display
Indicates the main power ON.
- 8 Central control display
Indicates when function is locked from central remote controller or PC controller.
- 9 Fan speed display
- 10 Set temperature
Indicates Error history number. *2)
Indicates Indoor unit address. *3)
- 11 Operation mode display
- 12 (Upper) Indicates the error code *1) *2) / the refrigerant system address. *3)
(Lower) Indicates the remote controller address. *1) *2) *3)

*1) during self Diagnosis mode.

*2) during Error code history display mode.

*3) during address display mode.

SPECIFICATIONS

Model name	UTB - *RA
Size [H x W x D (mm)]	120 x 75 x 14
Weight (g)	90

SYSTEM DIAGRAM

- 1 remote controller
- 2 remote controllers

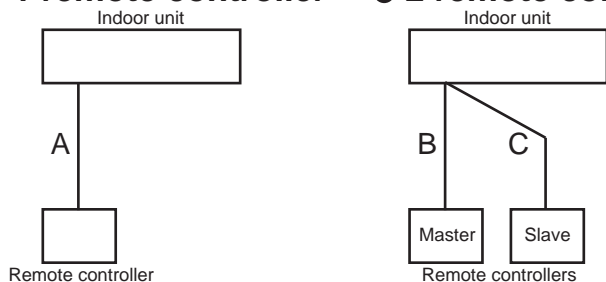

A, B, C : Remote controller cable. Refer to 5-2-1 for detail specifications.
A ≤ 500m ; B+C ≤ 500m

PACKING LIST

Name	Quantity	Application
Simple remote controller	1	
Remote controller cable *4)	10m	For connecting the remote controller (Exclude some models)
Tapping screw(M4x16mm)	2	For installing the remote controller
Binder	1	For remote controller and remote controller cable binding

*4) If necessary, use shielded cable (Field supply) in accordance with the standard of the country.

■ DIMENSION

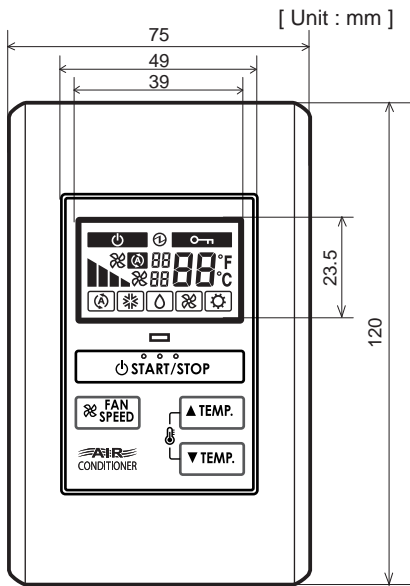

Front View

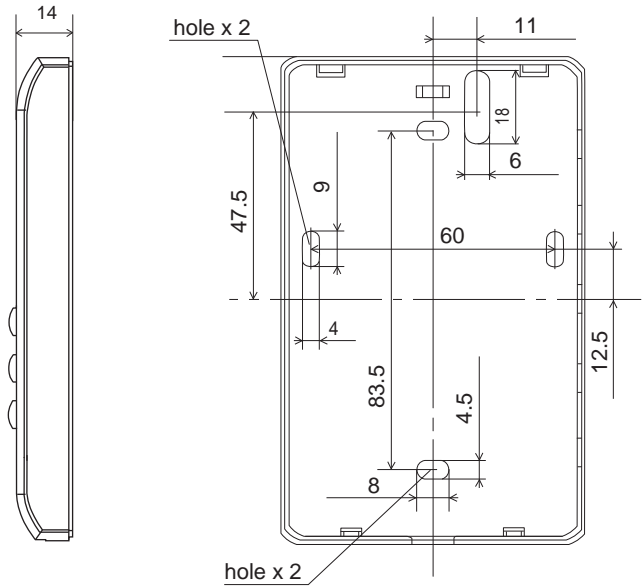

Rear View

■ ELECTRICAL WIRING

● 1 remote controller

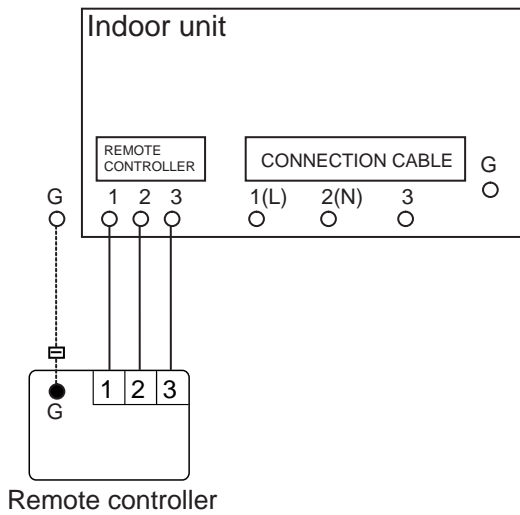

● 2 remote controllers

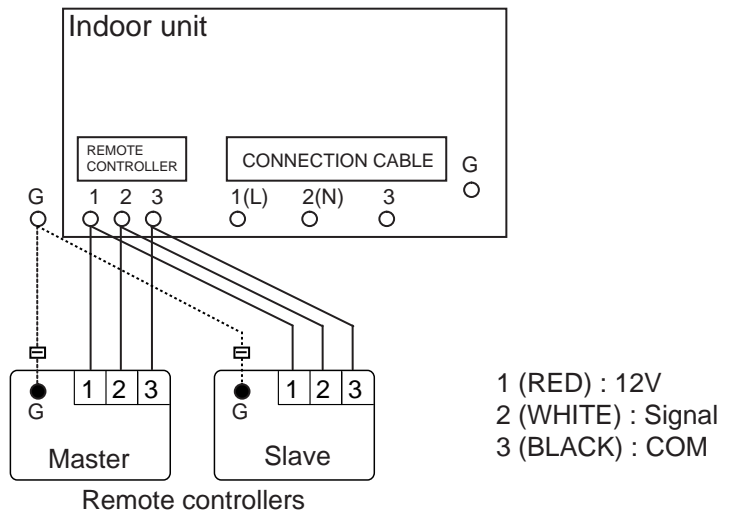

2-2-5.GROUP REMOTE CONTROLLER (Option)

Model : UTB - *DB [Market region Y or G] (GROUP REMOTE CONTROLLER)
UTR - YGCA (NETWORK CONVERTOR)

Only one group remote controller can be used in a system.
When it is used, network convertor (an optional parts UTR-YGCA) is necessary.

■ FEATURES

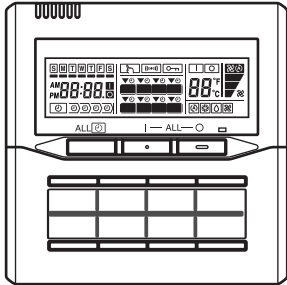

- * Up to 8 indoor units can be controlled with a single controller.
- * On/off, operation mode, set temperature, timer control and air flow can be controlled/monitored centrally or individually.
- * Easy installation with a slim shape with no bulge in the back.
- * One-touch ON/OFF operation of each indoor unit is possible. All the indoor units can also be easily operated by pressing an ALL ON, ALL OFF, or ALL TIMER ON/OFF button.

● High performance and compact size

ON/OFF, operation mode, set temperature and air flow can be controlled / monitored centrally or individually.

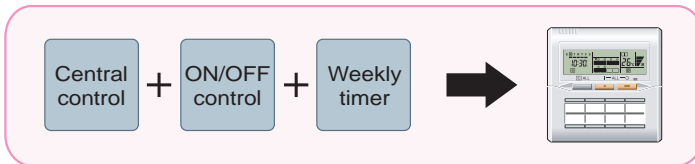

● Built-in weekly timers

The WEEKLY TIMER is provided as a standard function.

1. The timer can be set up for up to 4 times/day. (On/Off, set temperature)
2. Allows separate settings for each day of the week.

ON/OFF switching

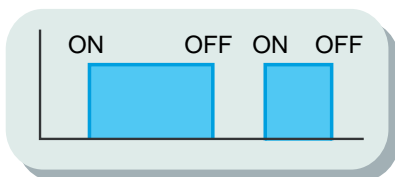

Temperature switching

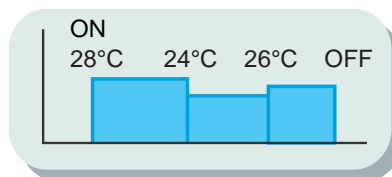

Stop setting

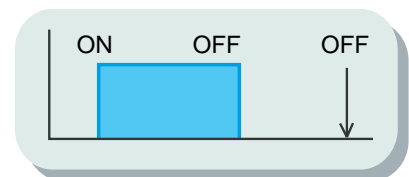

FUNCTIONS

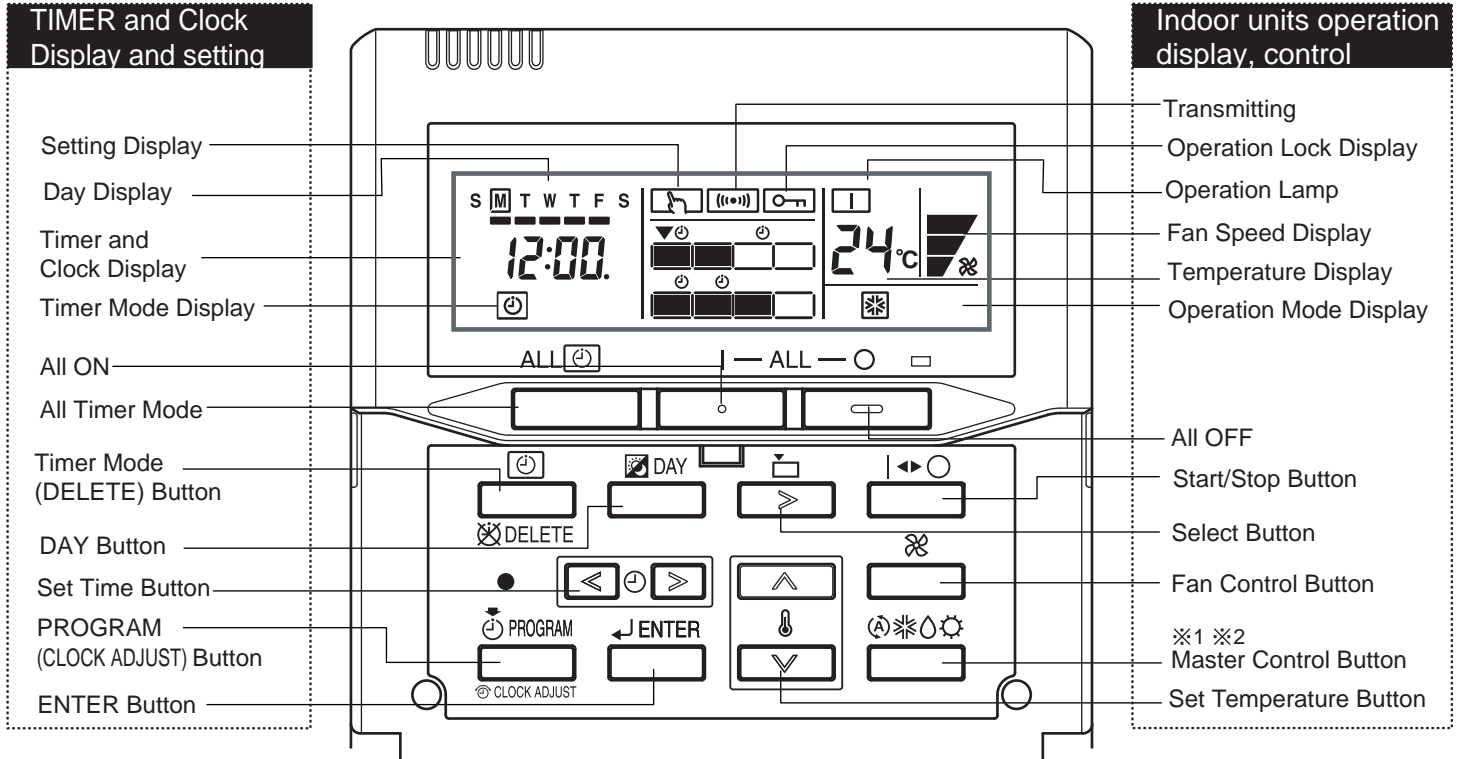

NOTE

- ※ 1 : "AUTO Ⓐ" and "FAN ⌘" cannot be selected for "HEAT PUMP TYPE"
- ※ 2 : "HEAT ⚙" cannot be selected for "COOLING ONLY TYPE"

SPECIFICATION

● Group remote controller (UTB - *DB)

Size [H x W x D (mm)]	120 x 120 x 17
Weight (g)	160

● Network convertor (UTR - YGCA)

Size [H x W x D (mm)]		85 x 216 x 313	
Weight (g)		1800	
Power source		AC 208V-240V 50/60Hz	
Power consumption		2.0W	
Environment	Operating	Temperature (°C)	0 - 46
		Humidity RH (%)	10 - 90
	Packaged	Temperature (°C)	-10 - 60
		Humidity RH (%)	10 - 90

Necessary if group remote controller is used.

PACKING LIST

● Group remote controller (UTB -*DB)

Name	Quantity	Application
Group remote controller	1	
Label	4	Use this for writing the names of the indoor units that have been registered.
Tapping screw(M4x16mm)	2	For installing the remote controller
Binder	1	For remote controller and remote controller cable binding

● Network convertor (UTR - YGCA)

Name	Quantity	Application
Network convertor	1	
Tapping screw(M4x16mm)	4	For installing the remote controller
Binder (Push mount)	4	For remote controller and remote controller cable binding
Cord bushing	2	

DIMENSION

● GROUP REMOTE CONTROLLER MODEL NAME : UTB -*DB

[Unit : mm]

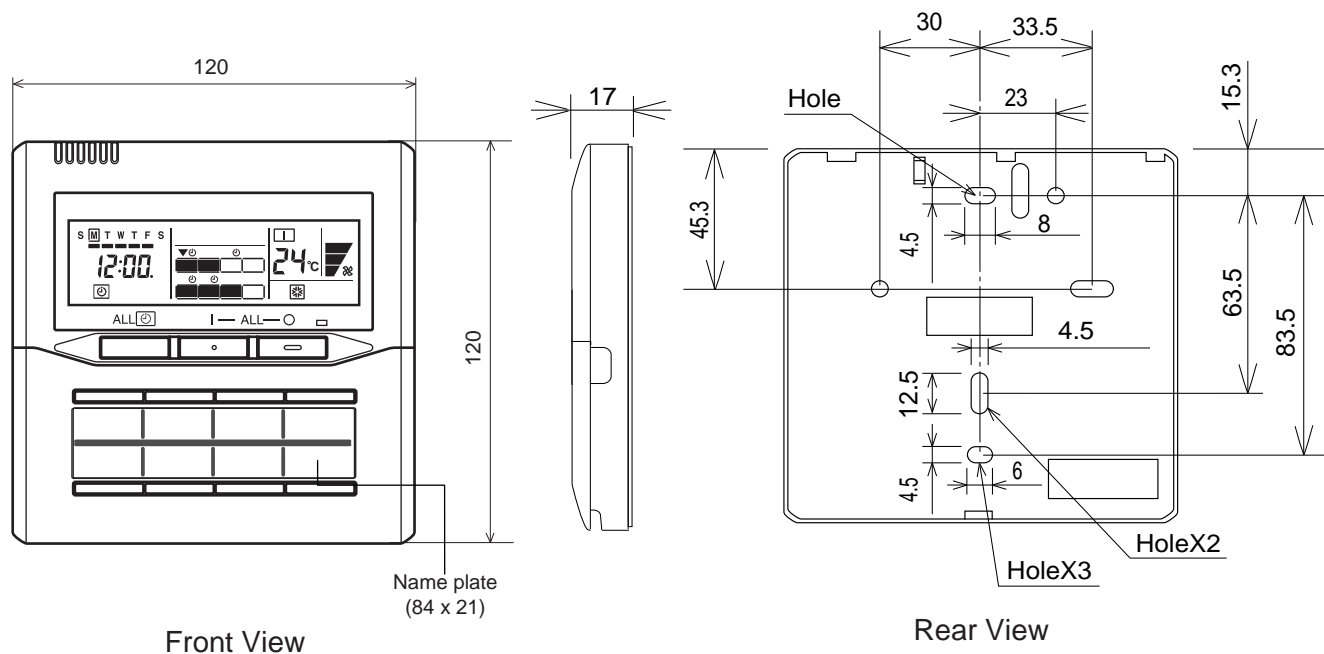

■ DIMENSION

● NETWORK CONVERTOR MODEL NAME : UTR - YGCA

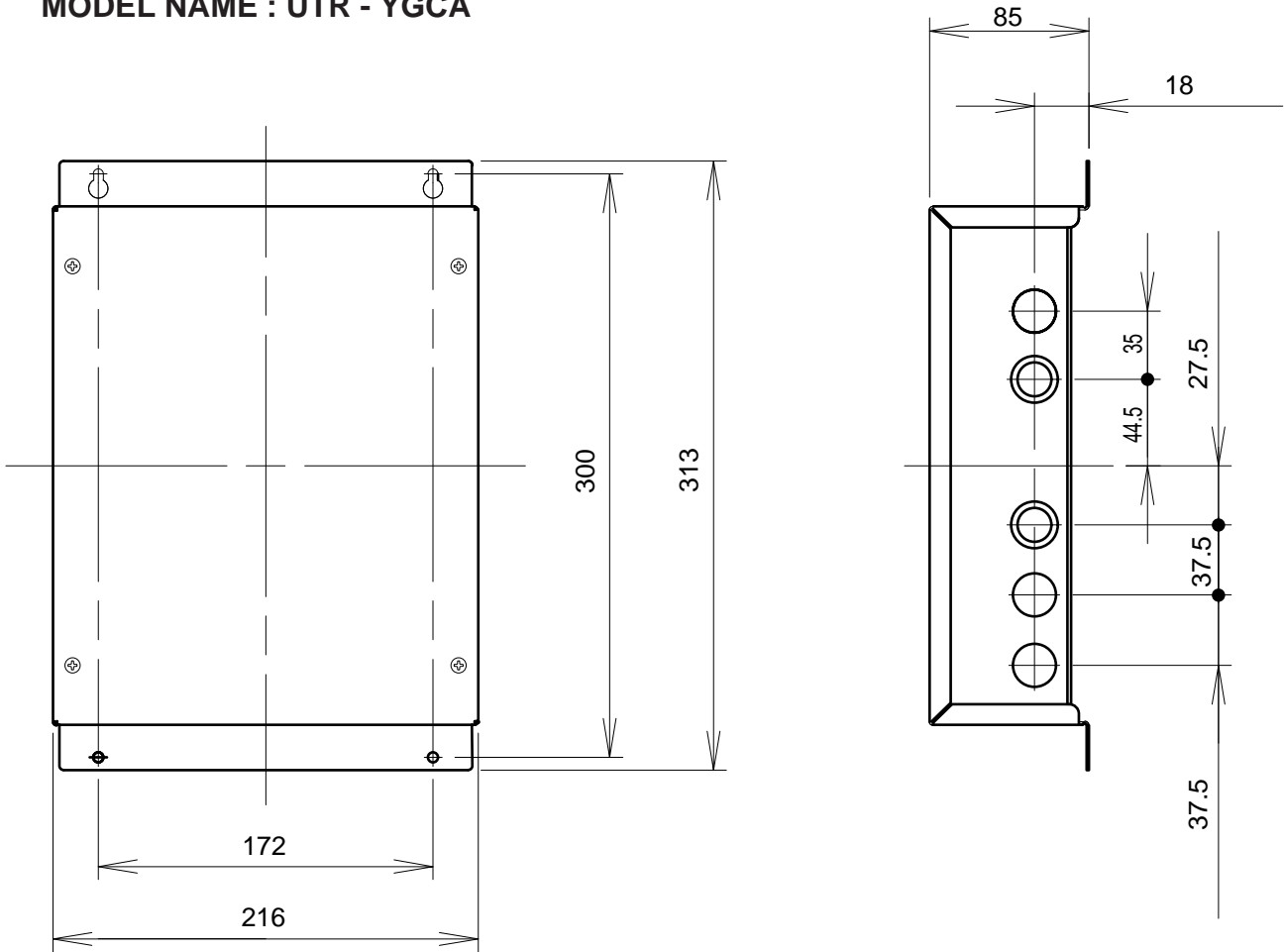

Refer the installation manual for mounting condition.

■ ELECTRICAL WIRING (UTB-***DB, UTR-YGCA)

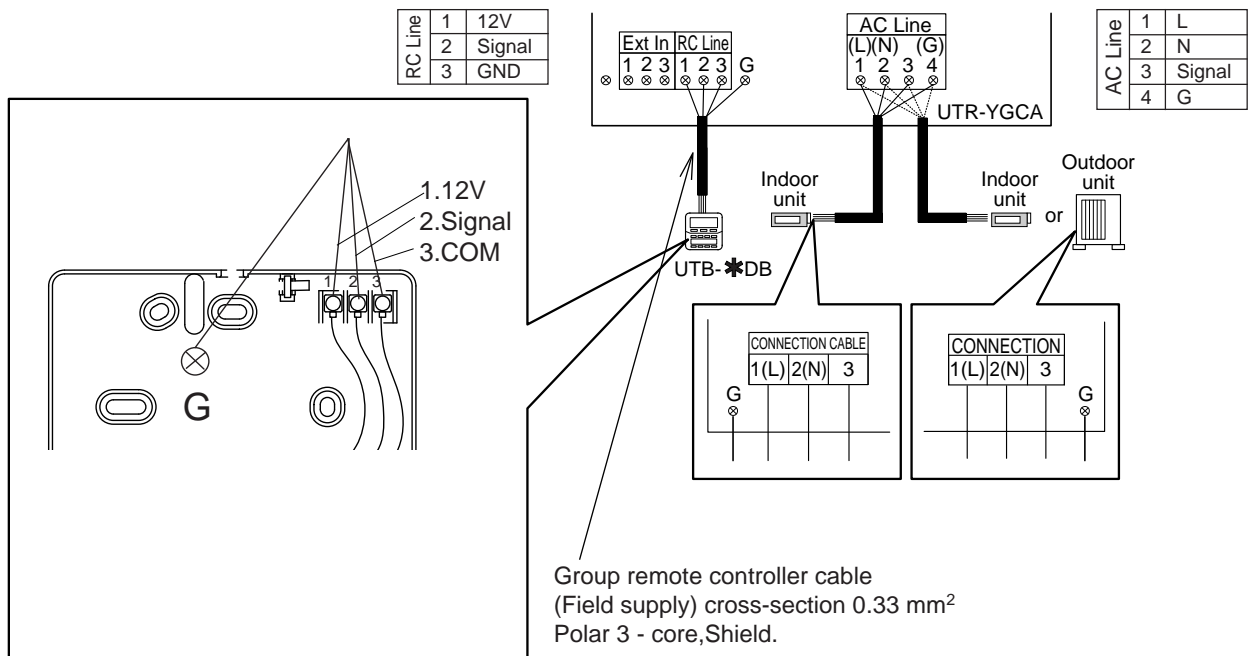

2-2-6. IR RECEIVER UNIT (Accessory)

IR receiver unit is an accessory of duct units.

■ FEATURES

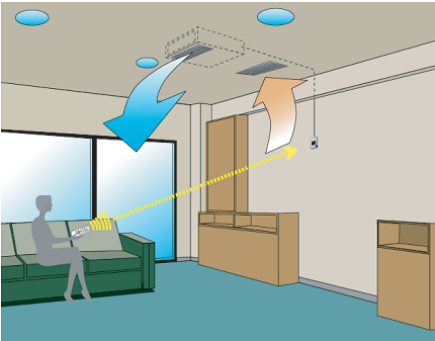

Duct type indoor unit can be controlled with wireless remote controller if the IR receiver unit is used.

■ FUNCTIONS

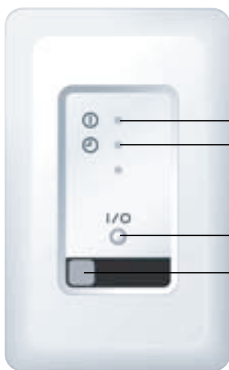

OPERATION LAMP
 TIMER LAMP
 MANUAL AUTO
 SIGNAL RECEIVER

■ DIMENSIONS

[Unit : mm]

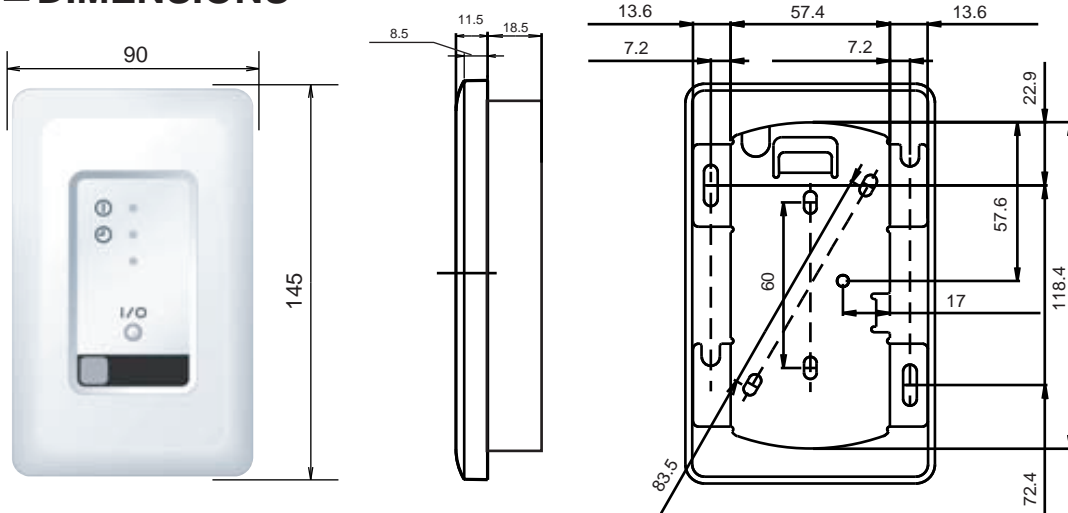

■ ATTACHMENT RANGE

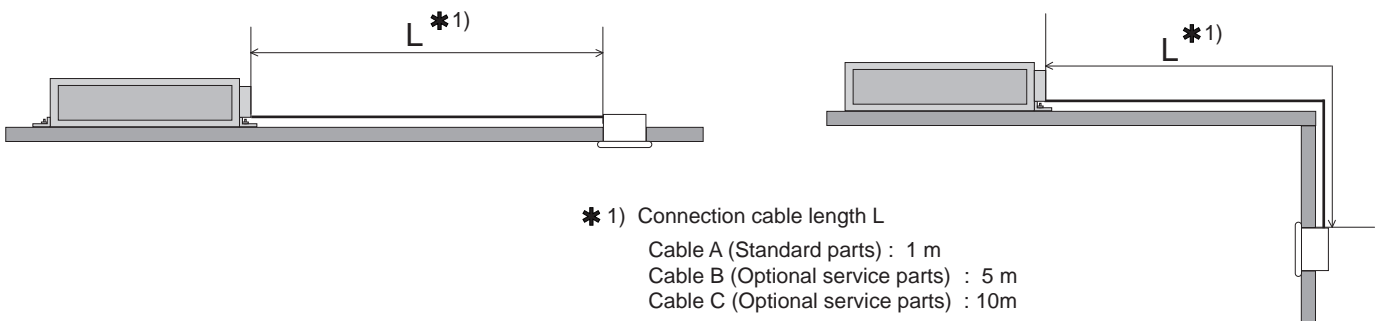

■ SIGNAL ANGLE

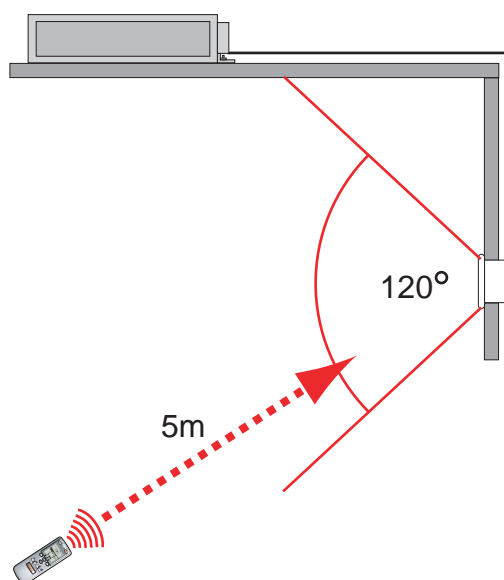
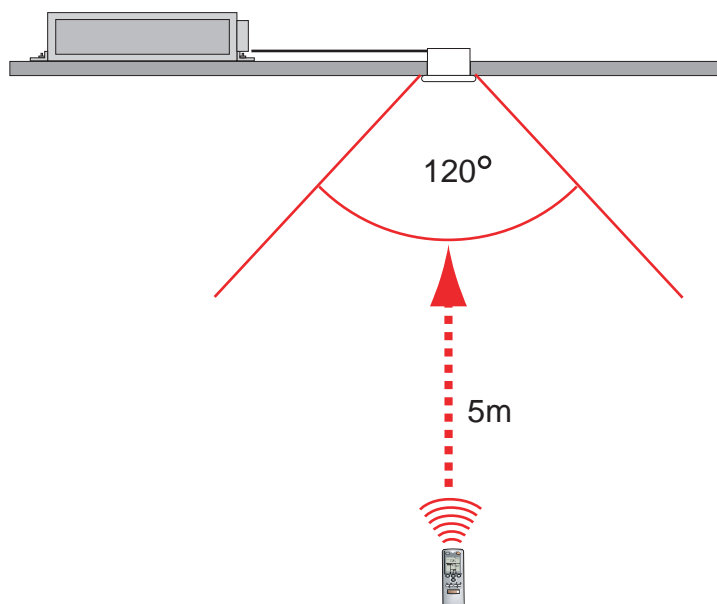

■ ELECTRICAL WIRING

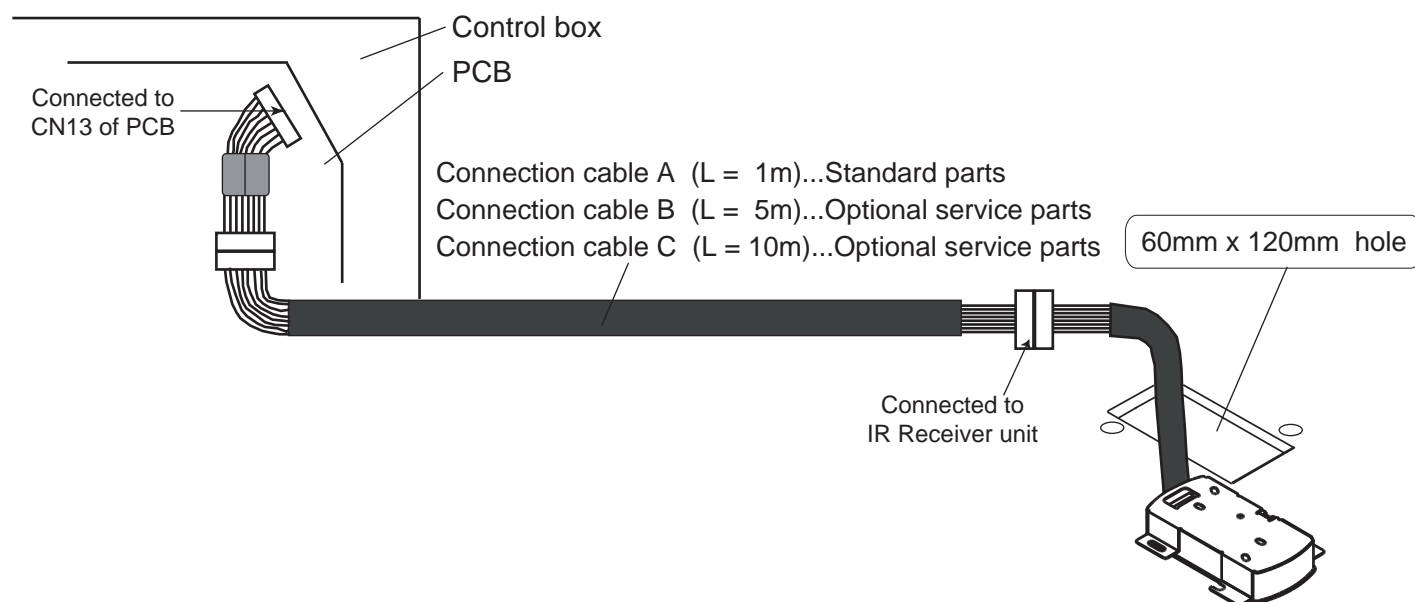

■ PACKING LIST

Name	Quantity
Holder (PCB)	1
PCB assy	1
Bracket (Holder)	1
Holder cover	1
Screw	4
Connection cable A (1m)	1

■ OPTIONAL SERVICE PARTS

Please use the parts number shown below to order the cable from your sales representative. Select shielded type connection cable in accordance with the standard of the country.

Parts name	Type	Parts No.
Connection cable B	Non-shielded	9378143005
	Shielded	9378143029
Connection cable C	Non-shielded	9378143012
	Shielded	9378143036

2-2-7.EXTERNAL SWITCH CONTROLLER [Option]

UTR-YESA

■ FEATURES



- Air conditioner switching can be controlled by connecting other sensor switches.
 - ON/OFF, Temperature, Fan speed and Operating mode can be switched by a combination with Card-key switch equipped in facilities such as hotel room.
- ※ Card-key or other sensor switches are available as a field supplied parts.

■ SYSTEM DIAGRAM

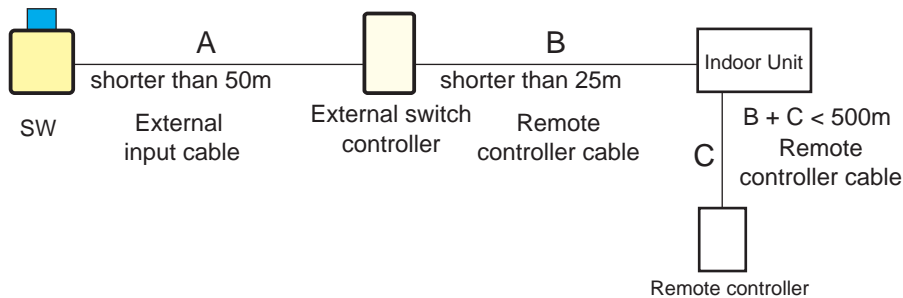

■ SPECIFICATIONS

Power supply	DC 12V
Size (H x W x D) (mm)	120 x 75 x 30
Weight (g)	90

■ PACKING LIST

Name	Quantity	Application
External switch controller	1	
Tapping screw(M4x16mm)	2	For installing the external switch controller
Binder	5	For external switch controller and cable binding

■ DIMENSIONS

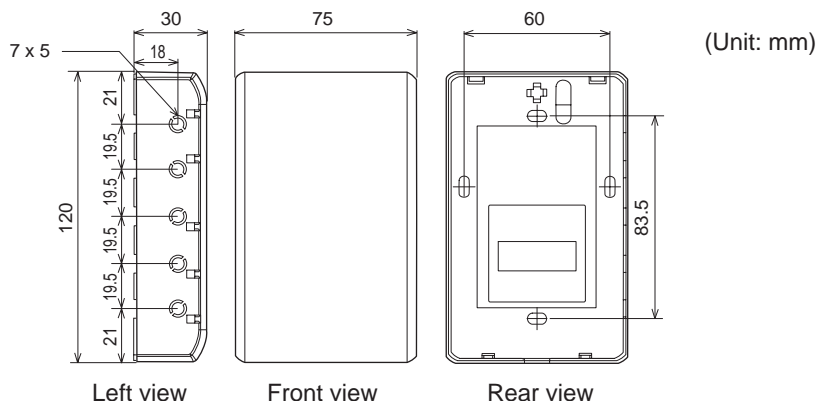

ELECTRICAL WIRING

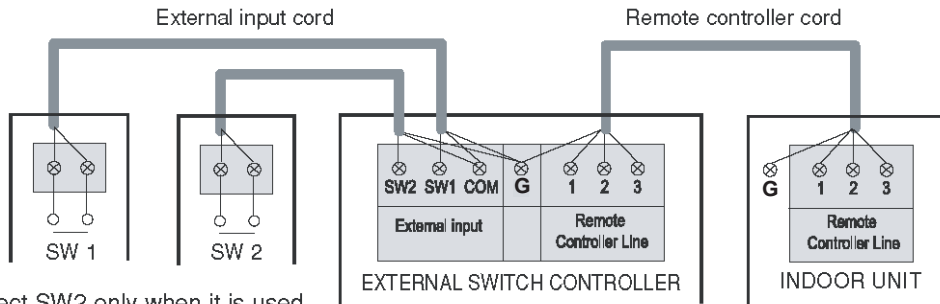

*Connect SW2 only when it is used.

Connection to external contacts

Non voltage

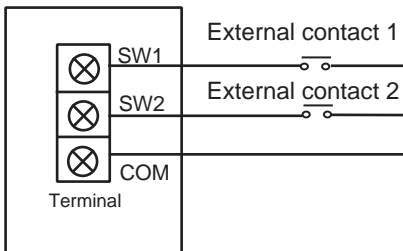

External switch controller

Open circuit voltage : 12 (V) ± 2 (V).
 Short circuit current : ≤ 2 (mA).
 Short circuit detection resistance (R_{ON}) : ≤ 1 (kilo-ohm).
 Open circuit detection resistance (R_{OFF}) : ≥ 50 (kilo-ohm).

WIRING SPECIFICATIONS

Use	Size	Wire type	Remarks
Remote controller cable (mm ²)	0.33 (22AWG)	Shielded	Polar 3 core Twisted pair
External input cable (mm ²)	0.33 (22AWG)	Shielded	Polar 2 core Twisted pair

EXAMPLE

Application	Setting	Wiring	Operation example
When controlling the individual operation states with two external contact	MODE0 P1: Arbitrary operation state Contact OFF ⇒ ON P2: Arbitrary operation state Contact OFF ⇒ ON Others setting are arbitrary.		<p>P1 : ON, COOL, 26°C P2 : OFF</p>

EXAMPLE

CONTROL SYSTEM

CONTROL SYSTEM

Application	Setting	Wiring	Operation example
When controlling operation by ON or OFF of an external contact switch	MODE1 P1 : Arbitrary operation state P2 : Arbitrary operation state Others setting are arbitrary.		P1 : OFF P2 : ON, COOL, 26°C SW1 ON OFF P2 P1 Operation state ON OFF COOL 26°C
When operating in the state set when an external contact switch was set to ON and returning to the original operation state when the switch was set to OFF	MODE1 or 0 P1 : SETBACK P2 : Arbitrary operation state Others setting are arbitrary.		MODE1, P1 : SETBACK P2 : ON, COOL, 26°C SW1 ON OFF P2 P1 Operation state ON OFF COOL 23°C COOL 26°C COOL 23°C
When operated in the state when an external contact switch was set to OFF and returned to original operation state	MODE1 or 0 P1 : Arbitrary operation state P2 : SETBACK Others setting are arbitrary.		MODE1, P1 : ON, COOL, 26°C P2 : When SETBACK SW1 ON P1 P2 OFF Operation state ON OFF COOL 23°C COOL 26°C COOL 23°C
When a temperature sensor switch is connected and cooling and heating and switching is performed.	MODE2 P1 : ON, COOL or HEAT P2 : ON, COOL or HEAT Operation conditions :Unit operating only Others setting are arbitrary.	<p>An external switch controller is connected to all the indoor units of the same refrigerant system and cooling and heating are switched by one temperature sensor.</p>	P1 : ON, COOL, 26°C P2 : ON, HEAT, 21°C SW1 ON P1 P2 OFF Operation state ON OFF COOL 23°C HEAT 21°C COOL 26°C
When preventing chattering noise within 1 minute of the external contact switch.	MODE1 Delay-time setting :Delay P1 : Arbitrary operation state P2 : Arbitrary operation state Others setting are arbitrary.		P1 : OFF P2 : ON, COOL, 26 °C SW1 ON OFF P2 P1 1min 1min Operation state ON OFF COOL 26°C

2-2-8.COMPARISON TABLE OF CONTROLLER

Table 1 List of Controller Functions

CONTROL SYSTEM		CONTROL SYSTEM					
		Wireless remote controller	Wired remote controller (UTB- *UB)	Simple remote controller (UTB- *PB)	Simple remote controller (UTB- *RA)	Group remote controller (UTB- *DB)	
Max. controllable indoor units		1	1	1	1	8	
Air conditioning control function	On / Off	○	○	○	○	○	
	Operation mode setting	○	○	○	-	○	
	Fan speed setting	○	○	○	○	○	
	Room temp. setting	○	○	○	○	○	
	Test operation	○	○	○	-	-	
	Up/down air direction flap setting	○	○	-	-	-	
	Right/left air direction flap setting	○	○	-	-	-	
Display	Address display	-	○	○	○	○	
	Failure	-	○	○	○	○	
	Defrosting	-	○	○	○	-	
	Current time	○	○	-	-	○	
	Day of week	-	○	-	-	○	
	Centrally controlling	-	○	○	○	-	
	Cooling/Heating priority	-	○	○	○	○	
	Error history	-	○	○	○	○	
Timer	On/Off timer	○	○	-	-	-	
	Weekly timer	-	○	-	-	○	
	Set back timer	-	○	-	-	-	
	Sleep timer	○	-	-	-	-	
	Program timer	○	-	-	-	-	
	On/Off per day	1	2	-	-	2	
	On/Off per week	-	14	-	-	14	
	Day off	-	○	-	-	-	
	Min. unit of timer setting	5	30	-	-	10	

AIRSTAGE™

J SERIES

3 . OUTDOOR UNITS

3-1. MODEL LINE UP

LINE UP

TYPE	CAPACITY	MODEL NAME	The number of connectable indoor unit
AIRSTAGE™ J Heat pump type	15.2 kW	AJ *A54LCLR AO*54UJBMR	1 to 8
AIRSTAGE™ J Cooling only type	15.2 kW	AJ *A54JCLR AO*54FJBMR	1 to 8

REFRIGERANT R410A

MODEL DESIGNATION

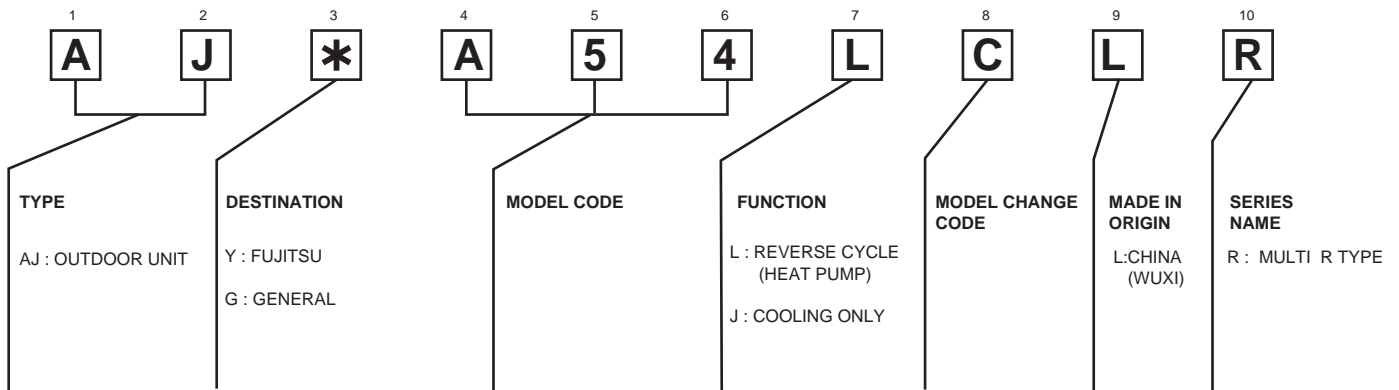
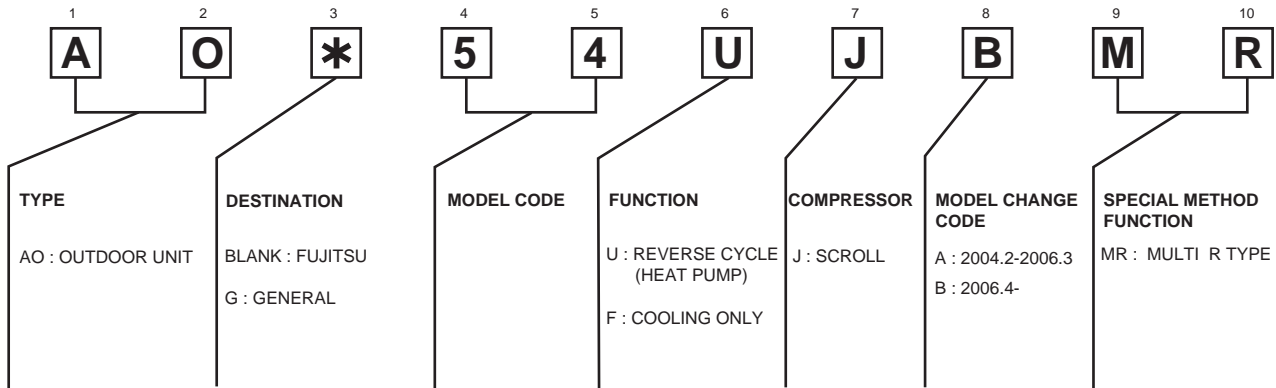

CAPACITY RANGE

CAPACITY	Indoor unit connectable capacity
15.2kW	7.60 to 22.8kW (50 to 150%)

OUTDOOR UNITS

OUTDOOR UNITS

3-2. SPECIFICATIONS

Model name			AJ * A54LCLR	AJ * A54JCLR	AO * 54UJBMR	AO * 54FJBMR
Power source			Single-phase, 220-240V, 50Hz		Single-phase, 220-240V, 50Hz	
Capacity	Cooling	[kW]	15.2		15.2	
	Heating		16.6	—	16.6	—
Input power	Cooling	[kW]	4.75		4.75	
	Heating		4.88	—	4.88	—
Current	Cooling	[A]	20.2		20.2	
	Heating		20.7	—	20.7	—
Starting current			18.5		18.5	
Maximum current			30, 25, 20, 15 ^{*1)}		30, 25, 20, 15 ^{*1)}	
COP	Cooling		3.20		3.20	
	Heating		3.40	—	3.40	—
Heat exchanger	Coil		Plate fin coil		Plate fin coil	
	Surface treatment		Corrosion resistance (Blue fin)		Hydrophilic coating	
	Rows x stages		3 x 40		3 x 40	
	Fin pitch	[mm]	1.45		1.45	
	Fin surface area	[m ²]	38.8		38.8	
Air circulation			5,250		5,250	
Fan type x number			Propeller x 1		Propeller x 1	
Fan motor output			150		150	
Noise level (sound pressure)	Normal operation mode	[dB(A)]	56		56	
	Silent operation mode		51	—	51	—
Compressor	Type		Scroll		Scroll	
	Driving method		DC inverter		DC inverter	
	Motor output	[W]	3,000		3,000	
Refrigerant	Type		R410A		R410A	
	Charge	[kg]	3.0		3.0	
Refrigerant oil	Type		Synthetic oil (POE oil)		Synthetic oil (POE oil)	
	Charge	[cc]	1,700		1,700	
Casing color			Beige (10YR7.5 / 1.0NN)		Beige (10YR7.5 / 1.0NN)	
Dimensions (H x W x D)	Net	[mm]	900 x 900 x 370 ^{*2)}		900 x 900 x 370 ^{*2)}	
	Gross		1,021 x 1,026 x 436		1,021 x 1,026 x 436	
Weight	Net	[kg]	97		97	
	Gross		112		112	
Safety devices			Fan motor thermal protector High pressure switch Low pressure switch Fuse		Fan motor thermal protector High pressure switch Low pressure switch Fuse	
Operation range	Cooling	[°C]	- 5 to 43		- 5 to 43	
	Heating		- 20 to 21	—	- 20 to 21	—
Pipe	Diameter	Liquid	φ9.52		φ9.52	
		Gas	φ19.05		φ19.05	
	Maximum Length		70		70	
	Maximum height difference		30		30	
Connection method			Flare		Flare	
Connectable indoor unit			1 to 8		1 to 8	
Connectable indoor unit capacity			50% to 150%		50% to 150%	

Note : Specifications are based on the following conditions.

Cooling : Indoor temperature of 27°CDB / 19°CWB, and outdoor temperature of 35°CDB / 24°CWB.

Heating : Indoor temperature of 20°CDB / (15°CWB), and outdoor temperature of 7°CDB / 6°CWB.

Voltage : 230 [V] ; Pipe length : 7.5[m] ; Height difference (Between outdoor unit and indoor unit) : 0[m]

*1): If capacity of the circuit breaker is smaller than 30[A] , preset of the DIP switch 2-3 and 2-4 is necessary(refer to 5-4-2 for the details).

Performance of the unit might be deteriorated if capacity of the circuit breaker is smaller than 30[A].

*2): When the valve cover is included,width becomes 979[mm].

3-3. DIMENSIONS

■ MODELS : AJ * A54L, AJ * A54J, AO * 54U , AO * 54F

(Unit : mm)

OUTDOOR
UNITS

OUTDOOR
UNITS

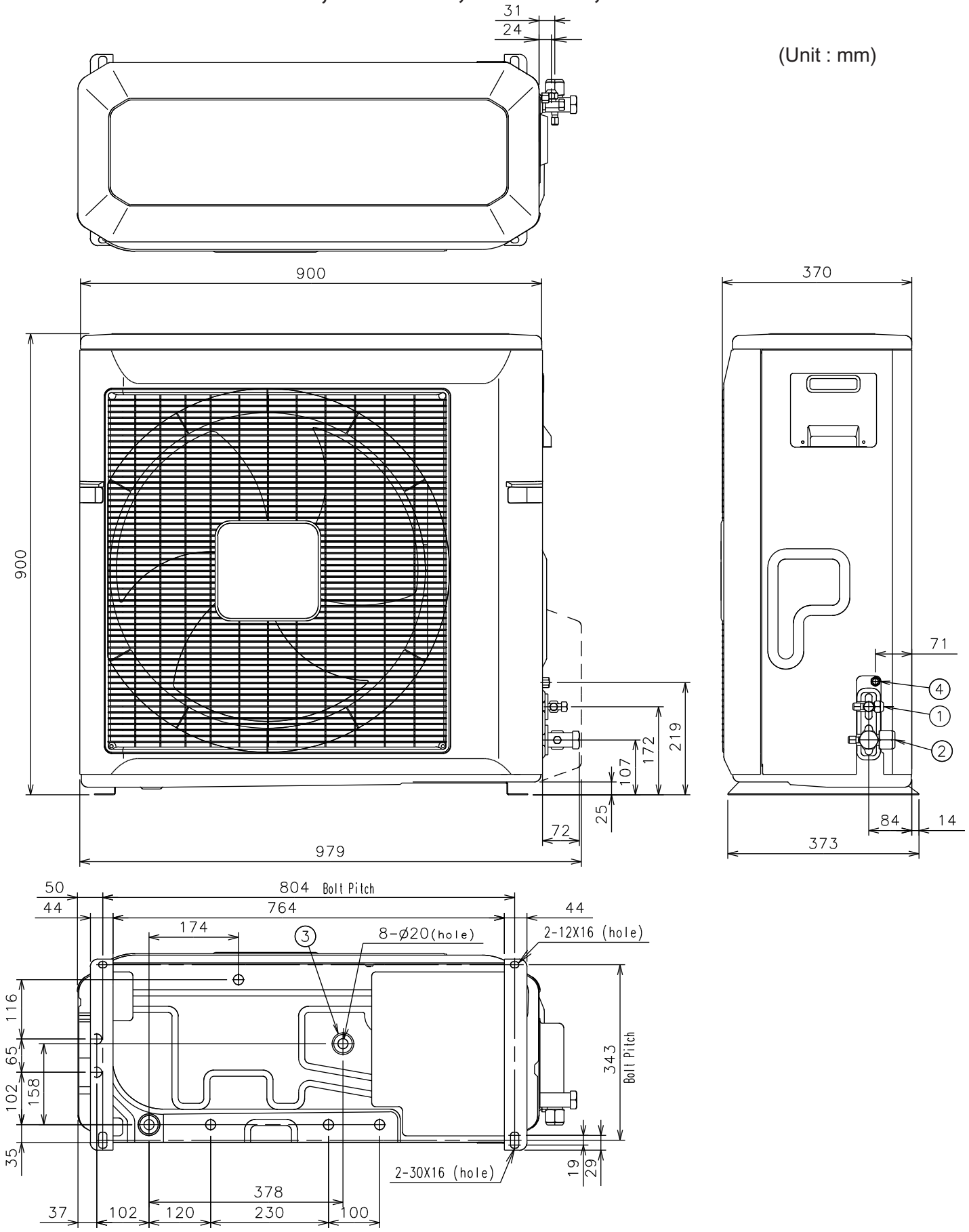

①	Refrigerant pipe flare connection	Liquid	ϕ 9.52mm
②		Gas	ϕ 19.05mm
③	Drain pipe mounting hole	Drain pipe	—
④	Check valve	—	—

3-4. INSTALLATION SPACE

- * Set the unit on a strong stand, such as one made of concrete blocks to minimize shock and vibration.
- * Do not set the unit directly on the ground because it will cause trouble.
- * Do not install the unit where a strong wind blows or where it is very dusty.
- * Install the unit so that it will not fall down or harm people.
- * If outdoor unit is not installed to specifications, capacity may drop because of a short-circuit. As a result, a high pressure error may occur.
- * Since specified values are minimum permissible measurements, install unit after duly considering the measurements required for installation location, piping work and maintenance.

■ FOR INDIVIDUALLY

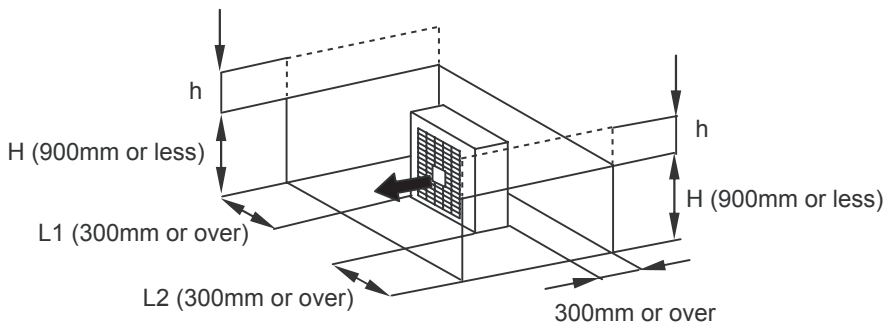

The height (H) of the side wall should be less than 900mm.
 If the height (H) of the side walls exceeds 900mm by h mm, and h mm to the space widths for L1 and L2.
 $H \leq 900 : L1 \geq 300, L2 \geq 300$
 $H > 900 : L1 > 300 + h, L2 > 300 + h$

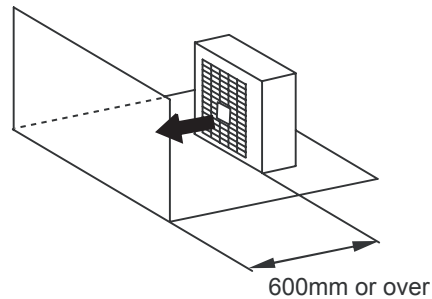
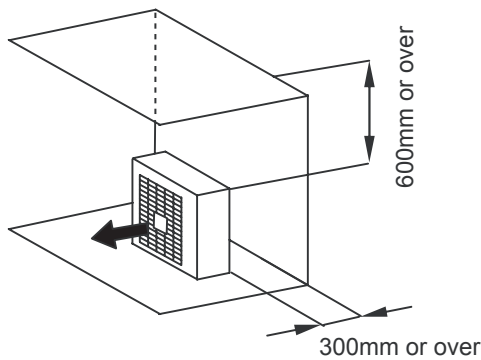

■ FOR CONTINUOUS

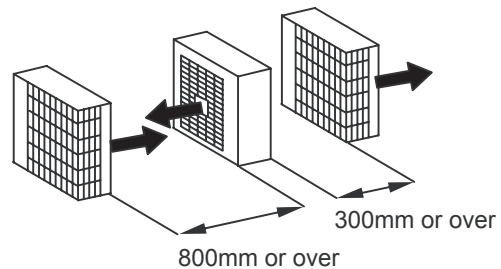
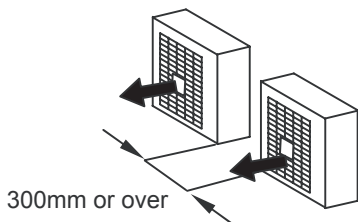

← : Air discharge

3-5. REFRIGERANT CIRCUIT

■ HEAT PUMP TYPE

- MODELS : AJ*A54L, AO*54U

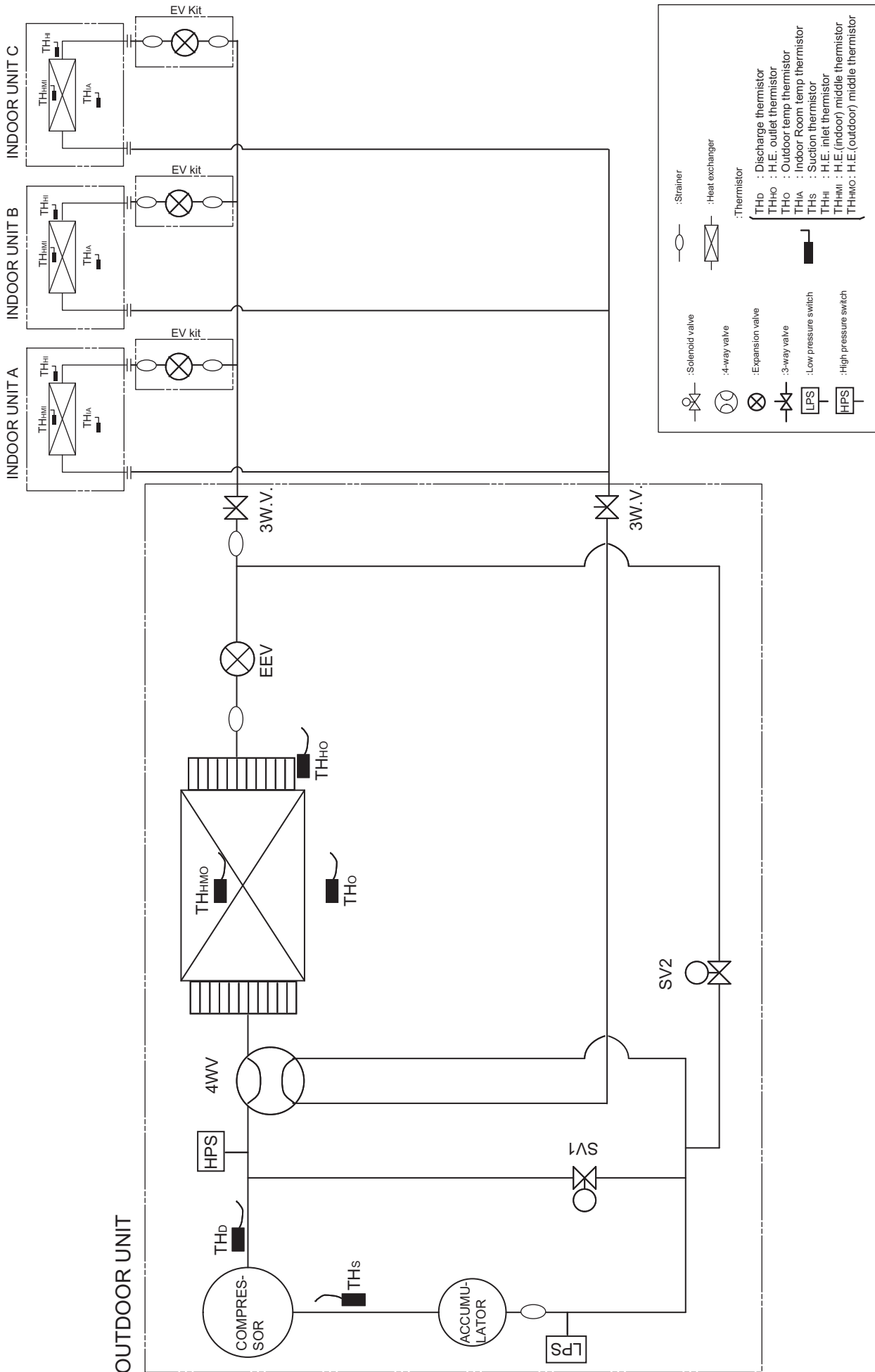

OUTDOOR
UNITS

OUTDOOR
UNITS

COOLING ONLY TYPE

MODELS : AJ*A54J, AO*54F

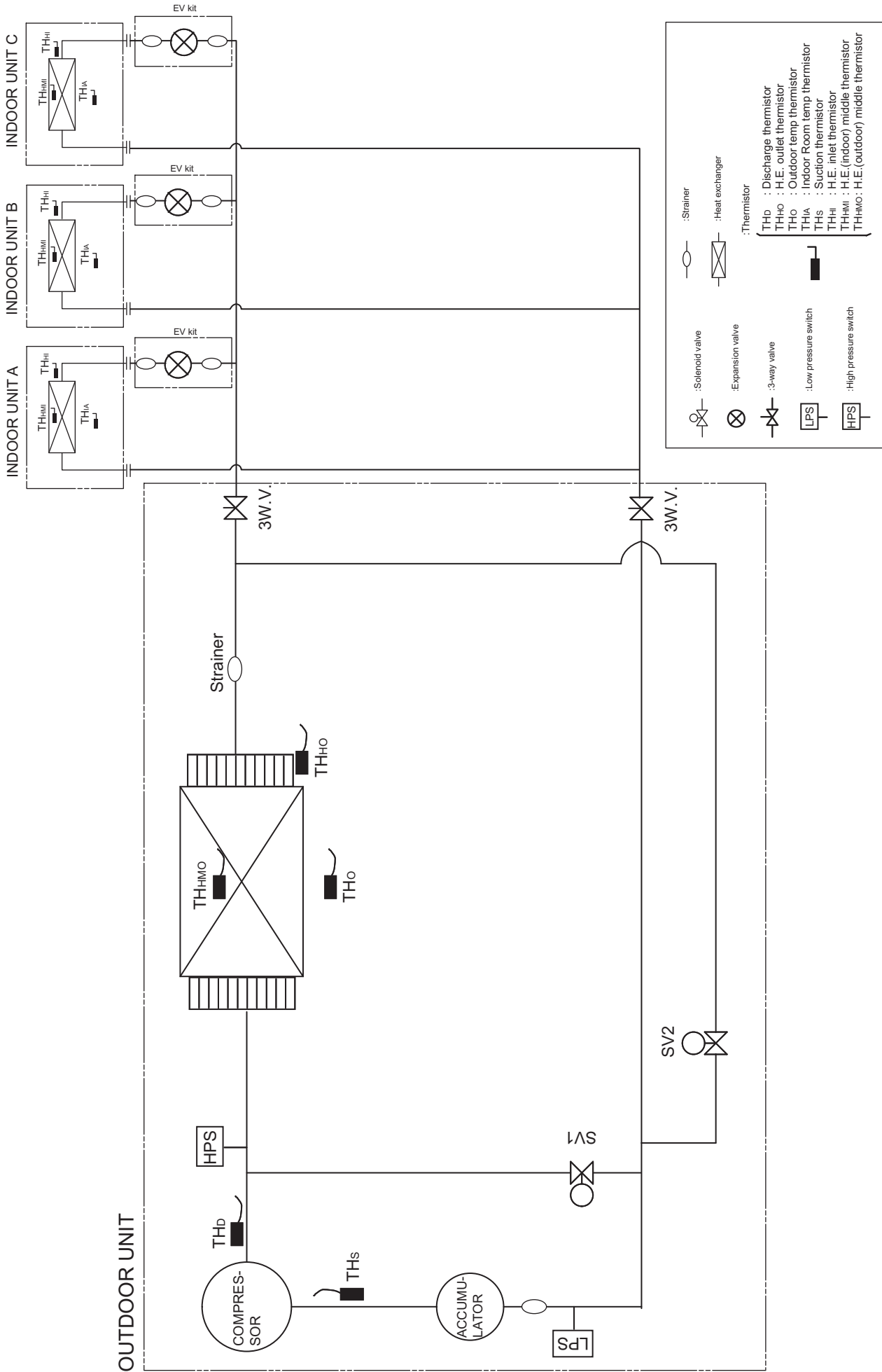

OUTDOOR UNITS

OUTDOOR UNITS

3-6. WIRING DIAGRAM

HEAT PUMP TYPE

- MODELS : AJ*A54L, AO*54U

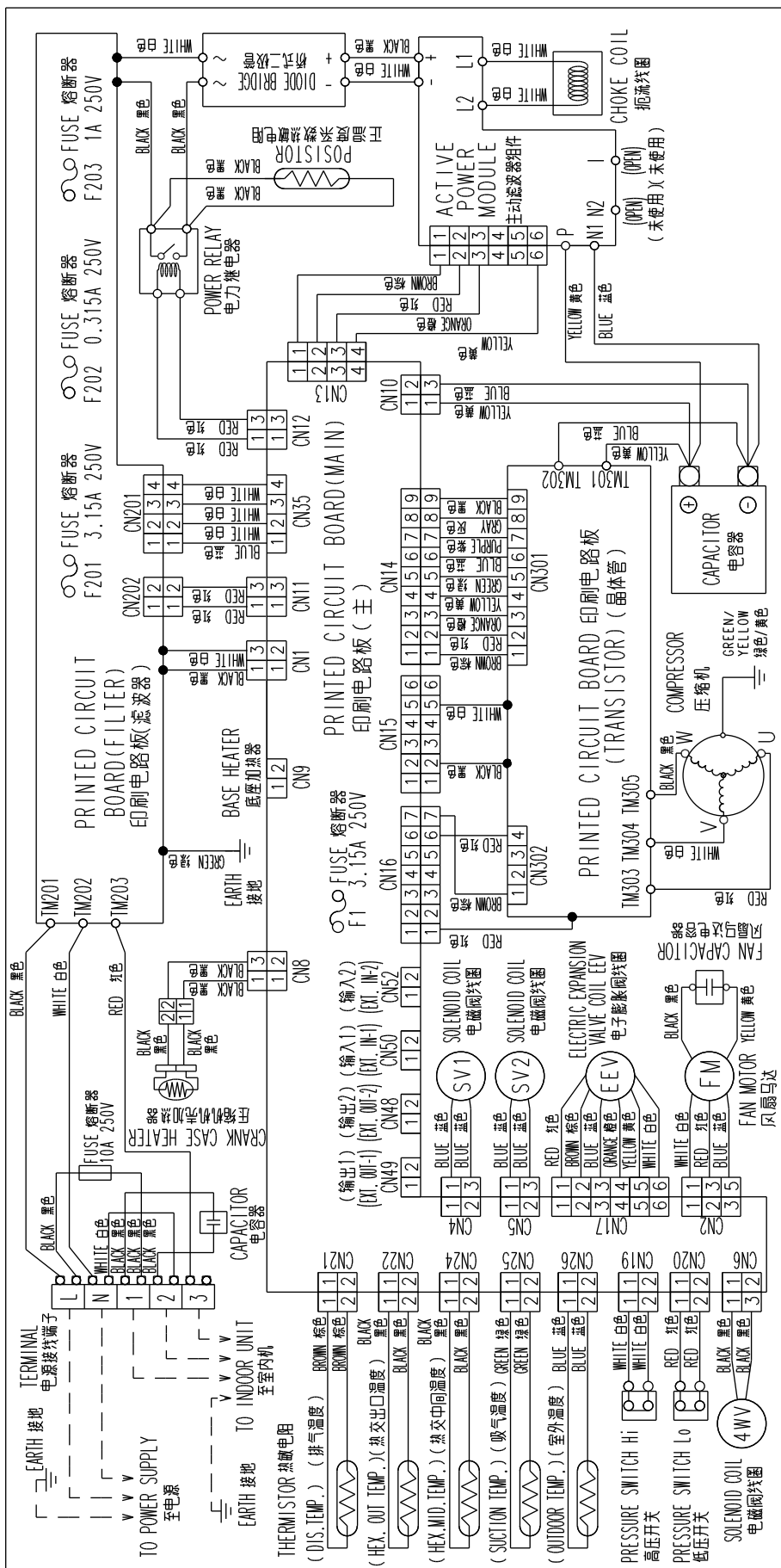

OUTDOOR
UNITS

OUTDOOR
UNITS

COOLING ONLY TYPE

MODELS : AJ*A54J, AO*54F

OUTDOOR
UNITS

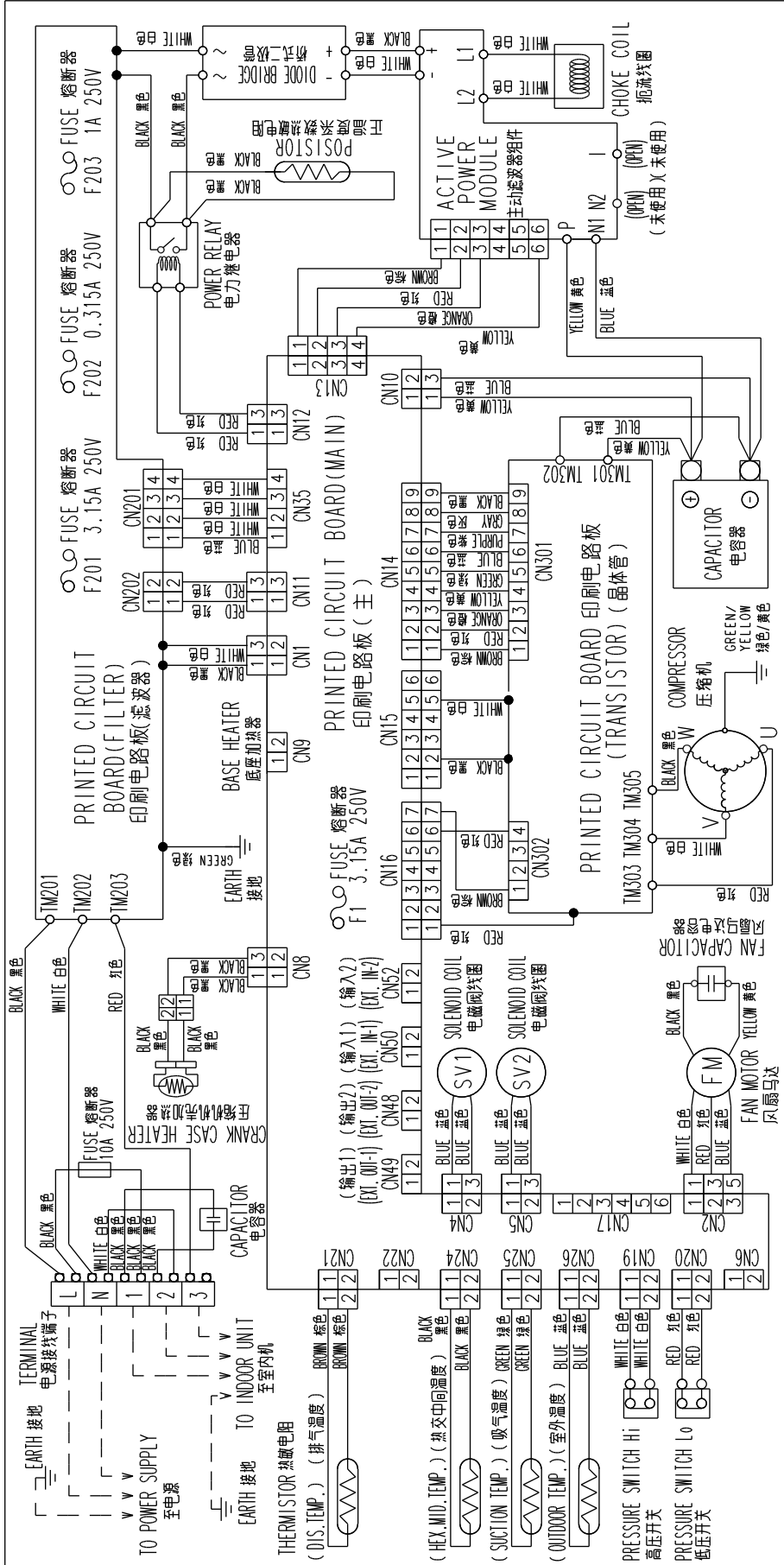

OUTDOOR
UNITS

3-7. CAPACITY TABLE

COOLING CAPACITY 30A

■ COOLING CAPACITY

• MODELS : AJ*A54L, AJ*A54J, AO*54U , AO*54F

Total Capacity of Indoor Unit (kW)	Outdoor Temperature		Indoor Temperature													
			20°CDB/15°CWB		23°CDB/16°CWB		26°CDB/18°CWB		27°CDB/19°CWB		28°CDB/20°CWB		30°CDB/22°CWB		32°CDB/23°CWB	
			68°FDB/59°FWB		73°FDB/61°FWB		79°FDB/64°FWB		81°FDB/66°FWB		82°FDB/68°FWB		86°FDB/72°FWB		90°FDB/73°FWB	
	(°CDB)	(°FDB)	TC	PI	TC	PI	TC	PI	TC	PI	TC	PI	TC	PI	TC	PI
22.8 (150%)	10	50	16.3	2.11	17.9	2.40	21.2	3.06	22.8	3.44	24.5	3.92	27.5	4.93	28.1	4.96
	15	59	16.3	2.59	17.9	2.96	21.2	3.79	22.8	4.30	24.5	4.87	26.5	5.53	27.1	5.55
	21	70	16.3	3.24	17.9	3.70	21.2	4.77	22.8	5.47	23.5	5.60	24.4	5.60	24.8	5.60
	23	73	16.3	3.49	17.9	3.96	21.2	5.15	22.3	5.60	22.8	5.60	23.6	5.60	24.0	5.60
	25	77	16.3	3.74	17.9	4.27	21.2	5.55	21.6	5.60	22.0	5.60	22.9	5.60	23.3	5.60
	27	81	16.3	3.98	17.9	4.59	20.5	5.60	20.9	5.60	21.3	5.60	22.2	5.60	22.6	5.60
	30	86	16.3	4.43	17.9	5.11	19.5	5.60	19.9	5.60	20.3	5.60	21.1	5.60	21.5	5.60
	33	91	16.3	4.92	17.8	5.60	18.6	5.60	18.9	5.60	19.3	5.60	20.1	5.60	20.4	5.60
	35	95	16.3	5.27	17.2	5.60	17.9	5.60	18.3	5.60	18.7	5.60	19.4	5.60	19.7	5.60
	37	99	16.3	5.61	16.6	5.60	17.3	5.60	17.6	5.60	17.9	5.60	18.6	5.60	19.0	5.60
	40	104	15.2	5.60	15.6	5.60	16.2	5.60	16.6	5.60	16.9	5.60	17.6	5.60	17.9	5.60
43	109	14.0	5.36	14.3	5.36	14.9	5.36	15.2	5.36	15.5	5.36	16.1	5.36	16.5	5.36	
21.3 (140%)	10	50	15.2	1.94	16.7	2.18	19.7	2.74	21.3	3.09	22.8	3.44	25.9	4.37	26.6	4.48
	15	59	15.2	2.39	16.7	2.68	19.7	3.37	21.3	3.81	22.8	4.28	25.1	5.01	25.6	5.03
	21	70	15.2	2.98	16.7	3.36	19.7	4.24	21.3	4.83	22.8	5.41	23.9	5.60	24.3	5.60
	23	73	15.2	3.18	16.7	3.60	19.7	4.58	21.3	5.21	22.3	5.60	23.2	5.60	23.6	5.60
	25	77	15.2	3.41	16.7	3.86	19.7	4.92	21.3	5.60	21.6	5.60	22.5	5.60	22.9	5.60
	27	81	15.2	3.65	16.7	4.13	19.7	5.34	20.6	5.60	21.0	5.60	21.8	5.60	22.2	5.60
	30	86	15.2	4.02	16.7	4.59	19.2	5.60	19.6	5.60	20.0	5.60	20.7	5.60	21.1	5.60
	33	91	15.2	4.45	16.7	5.08	18.3	5.60	18.6	5.60	19.0	5.60	19.7	5.60	20.1	5.60
	35	95	15.2	4.75	16.7	5.43	17.7	5.60	18.0	5.60	18.4	5.60	19.1	5.60	19.4	5.60
	37	99	15.2	5.08	16.3	5.60	17.0	5.60	17.3	5.60	17.7	5.60	18.4	5.60	18.7	5.60
	40	104	15.0	5.60	15.4	5.60	16.0	5.60	16.3	5.60	16.6	5.60	17.3	5.60	17.6	5.60
43	109	13.8	5.36	14.1	5.36	14.7	5.36	15.0	5.36	15.3	5.36	15.9	5.36	16.2	5.36	
19.8 (130%)	10	50	14.1	1.81	15.5	1.98	18.4	2.47	19.8	2.74	21.2	3.06	24.1	3.81	25.0	4.03
	15	59	14.1	2.18	15.5	2.44	18.4	3.06	19.8	3.38	21.2	3.78	23.7	4.53	24.1	4.55
	21	70	14.1	2.72	15.5	3.05	18.4	3.84	19.8	4.28	21.2	4.77	22.6	5.12	23.0	5.15
	23	73	14.1	2.92	15.5	3.27	18.4	4.11	19.8	4.60	21.2	5.18	22.2	5.32	22.7	5.34
	25	77	14.1	3.11	15.5	3.50	18.4	4.44	19.8	4.94	21.0	5.46	21.9	5.51	22.3	5.53
	27	81	14.1	3.33	15.5	3.76	18.4	4.76	19.8	5.35	20.6	5.60	21.3	5.60	21.7	5.60
	30	86	14.1	3.67	15.5	4.13	18.4	5.27	19.2	5.60	19.6	5.60	20.3	5.60	20.7	5.60
	33	91	14.1	4.02	15.5	4.56	17.9	5.60	18.3	5.60	18.7	5.60	19.4	5.60	19.7	5.60
	35	95	14.1	4.29	15.5	4.87	17.3	5.60	17.7	5.60	18.0	5.60	18.7	5.60	19.1	5.60
	37	99	14.1	4.58	15.5	5.23	16.7	5.60	17.1	5.60	17.4	5.60	18.0	5.60	18.4	5.60
	40	104	14.1	5.12	15.1	5.60	15.7	5.60	16.1	5.60	16.4	5.60	17.0	5.60	17.3	5.60
43	109	13.6	5.36	13.9	5.36	14.5	5.36	14.8	5.36	15.1	5.36	15.7	5.36	16.0	5.36	
18.2 (120%)	10	50	13.0	1.71	14.3	1.83	17.0	2.22	18.2	2.45	19.5	2.72	22.2	3.29	23.4	3.62
	15	59	13.0	2.00	14.3	2.22	17.0	2.73	18.2	3.00	19.5	3.34	22.2	4.08	22.6	4.10
	21	70	13.0	2.49	14.3	2.76	17.0	3.43	18.2	3.79	19.5	4.20	21.2	4.64	21.6	4.65
	23	73	13.0	2.66	14.3	2.97	17.0	3.69	18.2	4.08	19.5	4.51	20.9	4.82	21.3	4.84
	25	77	13.0	2.84	14.3	3.17	17.0	3.96	18.2	4.37	19.5	4.88	20.5	4.99	20.9	5.01
	27	81	13.0	3.04	14.3	3.39	17.0	4.24	18.2	4.68	19.4	5.13	20.2	5.17	20.6	5.19
	30	86	13.0	3.33	14.3	3.74	17.0	4.68	18.2	5.21	18.8	5.39	19.6	5.43	20.0	5.45
	33	91	13.0	3.67	14.3	4.10	17.0	5.20	17.9	5.60	18.3	5.60	19.0	5.60	19.3	5.60
	35	95	13.0	3.90	14.3	4.41	17.0	5.59	17.3	5.60	17.7	5.60	18.4	5.60	18.7	5.60
	37	99	13.0	4.13	14.3	4.69	16.4	5.60	16.7	5.60	17.1	5.60	17.7	5.60	18.0	5.60
	40	104	13.0	4.58	14.3	5.24	15.4	5.60	15.8	5.60	16.1	5.60	16.7	5.60	17.0	5.60
43	109	13.0	5.15	13.6	5.36	14.2	5.36	14.5	5.36	14.8	5.36	15.4	5.36	15.7	5.36	
16.7 (110%)	10	50	11.9	1.62	13.1	1.72	15.5	1.99	16.7	2.18	17.9	2.40	20.3	2.85	21.5	3.14
	15	59	11.9	1.83	13.1	2.02	15.5	2.44	16.7	2.69	17.9	2.95	20.3	3.51	21.1	3.68
	21	70	11.9	2.26	13.1	2.51	15.5	3.06	16.7	3.37	17.9	3.70	19.7	4.18	20.1	4.20
	23	73	11.9	2.43	13.1	2.69	15.5	3.28	16.7	3.62	17.9	3.97	19.4	4.35	19.8	4.37
	25	77	11.9	2.59	13.1	2.87	15.5	3.51	16.7	3.88	17.9	4.25	19.1	4.52	19.5	4.53
	27	81	11.9	2.76	13.1	3.06	15.5	3.75	16.7	4.14	17.9	4.58	18.8	4.68	19.2	4.70
	30	86	11.9	3.02	13.1	3.38	15.5	4.15	16.7	4.60	17.6	4.88	18.3	4.92	18.7	4.94
	33	91	11.9	3.32	13.1	3.69	15.5	4.56	16.7	5.10	17.1	5.12	17.8	5.15	18.2	5.17
	35	95	11.9	3.52	13.1	3.93	15.5	4.89	16.4	5.25	16.8	5.27	17.5	5.31	17.9	5.33
	37	99	11.9	3.73	13.1	4.20	15.5	5.23	16.1	5.40	16.4	5.43	17.1	5.48	17.5	5.51
	40	104	11.9	4.10	13.1	4.61	15.1	5.60	15.4	5.60	15.7	5.60	16.3	5.60	16.6	5.60
43	109	11.9	4.56	13.1	5.20	13.9	5.36	14.2	5.36	14.5	5.36	15.1	5.36	15.4	5.36	

TC : Total Capacity kW

PI : Power Input kW (Comp. + Outdoor fan motor)

The data is based on the following conditions. Pipe length : 7.5m ; Height difference : 0 m.

COOLING CAPACITY 30A

COOLING CAPACITY

• MODELS : AJ*A54L, AJ*A54J, AO*54U , AO*54F

Total Capacity of Indoor Unit (kW)	Outdoor Temperature (°CDB) (°FDB)		Indoor Temperature													
			20°CDB/15°CWB		23°CDB/16°CWB		26°CDB/18°CWB		27°CDB/19°CWB		28°CDB/20°CWB		30°CDB/22°CWB		32°CDB/23°CWB	
			TC	PI	TC	PI	TC	PI	TC	PI	TC	PI	TC	PI	TC	PI
15.2 (100%)	10	50	10.8	1.52	11.9	1.62	14.1	1.81	15.2	1.94	16.3	2.11	18.5	2.49	19.5	2.69
	15	59	10.8	1.67	11.9	1.83	14.1	2.18	15.2	2.38	16.3	2.60	18.5	3.07	19.5	3.30
	21	70	10.8	2.06	11.9	2.27	14.1	2.73	15.2	2.97	16.3	3.24	18.3	3.76	18.6	3.77
	23	73	10.8	2.20	11.9	2.43	14.1	2.90	15.2	3.18	16.3	3.49	18.0	3.92	18.3	3.93
	25	77	10.8	2.35	11.9	2.58	14.1	3.11	15.2	3.40	16.3	3.74	17.7	4.07	18.0	4.08
	27	81	10.8	2.50	11.9	2.76	14.1	3.32	15.2	3.66	16.3	3.99	17.4	4.22	17.7	4.23
	30	86	10.8	2.73	11.9	3.02	14.1	3.66	15.2	4.02	16.3	4.42	17.0	4.44	17.3	4.46
	33	91	10.8	3.00	11.9	3.31	14.1	4.04	15.2	4.44	15.8	4.63	16.5	4.66	16.8	4.67
	35	95	10.8	3.17	11.9	3.52	14.1	4.29	15.2	4.75	15.5	4.77	16.2	4.80	16.5	4.82
	37	99	10.8	3.36	11.9	3.73	14.1	4.58	14.9	4.89	15.2	4.91	15.9	4.94	16.2	4.96
13.7 (90%)	10	50	9.78	1.43	10.7	1.51	12.7	1.69	13.7	1.77	14.6	1.86	16.6	2.15	17.6	2.34
	15	59	9.78	1.52	10.7	1.65	12.7	1.95	13.7	2.11	14.6	2.28	16.6	2.65	17.6	2.87
	21	70	9.78	1.87	10.7	2.04	12.7	2.42	13.7	2.63	14.6	2.85	16.6	3.33	17.1	3.38
	23	73	9.78	2.00	10.7	2.18	12.7	2.59	13.7	2.82	14.6	3.05	16.5	3.51	16.8	3.52
	25	77	9.78	2.13	10.7	2.33	12.7	2.77	13.7	3.01	14.6	3.26	16.2	3.65	16.5	3.66
	27	81	9.78	2.26	10.7	2.47	12.7	2.96	13.7	3.21	14.6	3.47	15.9	3.79	16.3	3.80
	30	86	9.78	2.48	10.7	2.71	12.7	3.25	13.7	3.53	14.6	3.83	15.5	3.99	15.9	4.00
	33	91	9.78	2.70	10.7	2.97	12.7	3.56	13.7	3.88	14.5	4.17	15.1	4.19	15.5	4.20
	35	95	9.78	2.86	10.7	3.14	12.7	3.79	13.7	4.14	14.3	4.30	14.9	4.32	15.2	4.34
	37	99	9.78	3.03	10.7	3.34	12.7	4.02	13.7	4.41	14.0	4.42	14.6	4.45	14.9	4.47
12.2 (80%)	10	50	8.69	1.33	9.55	1.41	11.3	1.56	12.2	1.64	13.0	1.72	14.8	1.87	15.7	2.01
	15	59	8.69	1.38	9.55	1.49	11.3	1.73	12.2	1.87	13.0	2.00	14.8	2.30	15.7	2.47
	21	70	8.69	1.69	9.55	1.83	11.3	2.14	12.2	2.31	13.0	2.49	14.8	2.87	15.5	3.01
	23	73	8.69	1.80	9.55	1.95	11.3	2.29	12.2	2.48	13.0	2.67	14.8	3.07	15.2	3.14
	25	77	8.69	1.92	9.55	2.08	11.3	2.45	12.2	2.64	13.0	2.84	14.7	3.26	15.0	3.27
	27	81	8.69	2.03	9.55	2.21	11.3	2.60	12.2	2.82	13.0	3.03	14.5	3.39	14.8	3.40
	30	86	8.69	2.22	9.55	2.42	11.3	2.86	12.2	3.09	13.0	3.34	14.1	3.57	14.4	3.58
	33	91	8.69	2.42	9.55	2.64	11.3	3.12	12.2	3.39	13.0	3.66	13.7	3.75	14.0	3.76
	35	95	8.69	2.56	9.55	2.79	11.3	3.31	12.2	3.61	12.9	3.85	13.5	3.87	13.8	3.88
	37	99	8.69	2.70	9.55	2.95	11.3	3.51	12.2	3.83	12.7	3.97	13.3	3.99	13.5	4.00
10.6 (70%)	10	50	7.60	1.24	8.37	1.30	9.88	1.43	10.6	1.50	11.4	1.57	12.9	1.71	13.7	1.78
	15	59	7.60	1.25	8.37	1.34	9.88	1.53	10.6	1.64	11.4	1.74	12.9	1.98	13.7	2.11
	21	70	7.60	1.52	8.37	1.64	9.88	1.89	10.6	2.02	11.4	2.16	12.9	2.46	13.7	2.62
	23	73	7.60	1.62	8.37	1.74	9.88	2.02	10.6	2.16	11.4	2.31	12.9	2.63	13.6	2.79
	25	77	7.60	1.72	8.37	1.86	9.88	2.15	10.6	2.30	11.4	2.46	12.9	2.81	13.4	2.90
	27	81	7.60	1.82	8.37	1.97	9.88	2.29	10.6	2.45	11.4	2.62	12.9	3.01	13.2	3.02
	30	86	7.60	1.98	8.37	2.15	9.88	2.50	10.6	2.68	11.4	2.88	12.6	3.18	12.9	3.18
	33	91	7.60	2.15	8.37	2.34	9.88	2.72	10.6	2.93	11.4	3.15	12.3	3.34	12.6	3.35
	35	95	7.60	2.27	8.37	2.46	9.88	2.89	10.6	3.11	11.4	3.34	12.1	3.45	12.3	3.46
	37	99	7.60	2.39	8.37	2.61	9.88	3.05	10.6	3.30	11.4	3.54	11.9	3.55	12.1	3.56
9.1 (60%)	10	50	6.52	1.14	7.17	1.20	8.46	1.31	9.12	1.37	9.78	1.43	11.1	1.54	11.7	1.60
	15	59	6.52	1.24	7.17	1.32	8.46	1.47	9.12	1.55	9.78	1.63	11.1	1.79	11.7	1.88
	21	70	6.52	1.36	7.17	1.46	8.46	1.66	9.12	1.76	9.78	1.87	11.1	2.10	11.7	2.23
	23	73	6.52	1.45	7.17	1.55	8.46	1.76	9.12	1.88	9.78	2.00	11.1	2.25	11.7	2.37
	25	77	6.52	1.53	7.17	1.64	8.46	1.87	9.12	2.00	9.78	2.12	11.1	2.39	11.7	2.54
	27	81	6.52	1.62	7.17	1.74	8.46	1.99	9.12	2.12	9.78	2.26	11.1	2.55	11.6	2.66
	30	86	6.52	1.76	7.17	1.89	8.46	2.17	9.12	2.31	9.78	2.47	11.1	2.80	11.3	2.81
	33	91	6.52	1.90	7.17	2.05	8.46	2.36	9.12	2.52	9.78	2.70	10.8	2.95	11.1	2.96
	35	95	6.52	2.01	7.17	2.16	8.46	2.49	9.12	2.67	9.78	2.85	10.6	3.05	10.9	3.05
	37	99	6.52	2.11	7.17	2.28	8.46	2.63	9.12	2.83	9.78	3.03	10.4	3.14	10.7	3.15
7.6 (50%)	10	50	5.43	1.05	5.97	1.10	7.05	1.19	7.60	1.24	8.14	1.29	9.22	1.38	9.78	1.43
	15	59	5.43	1.13	5.97	1.18	7.05	1.30	7.60	1.37	8.14	1.43	9.22	1.56	9.78	1.63
	21	70	5.43	1.21	5.97	1.29	7.05	1.44	7.60	1.52	8.14	1.60	9.22	1.78	9.78	1.87
	23	73	5.43	1.28	5.97	1.36	7.05	1.53	7.60	1.62	8.14	1.71	9.22	1.90	9.78	2.00
	25	77	5.43	1.36	5.97	1.44	7.05	1.62	7.60	1.72	8.14	1.81	9.22	2.02	9.78	2.13
	27	81	5.43	1.43	5.97	1.52	7.05	1.71	7.60	1.82	8.14	1.92	9.22	2.15	9.78	2.26
	30	86	5.43	1.55	5.97	1.65	7.05	1.87	7.60	1.98	8.14	2.10	9.22	2.34	9.73	2.45
	33	91	5.43	1.67	5.97	1.78	7.05	2.02	7.60	2.15	8.14	2.28	9.22	2.55	9.49	2.58
	35	95	5.43	1.75	5.97	1.88	7.05	2.13	7.60	2.27	8.14	2.41	9.14	2.67	9.34	2.67
	37	99	5.43	1.84	5.97	1.97	7.05	2.25	7.60	2.40	8.14	2.54	8.98	2.75	9.18	2.75

TC : Total Capacity kW

PI : Power Input kW (Comp. + Outdoor fan motor)

The data is based on the following conditions. Pipe length : 7.5m ; Height difference : 0 m.

COOLING CAPACITY

COOLING CAPACITY 25A

• MODELS : AJ*A54L, AJ*A54J, AO*54U , AO*54F

Total Capacity of Indoor Unit (kW)	Outdoor Temperature (°CDB) (°FDB)		Indoor Temperature													
			20°CDB/15°CWB 68°FDB/59°FWB		23°CDB/16°CWB 73°FDB/61°FWB		26°CDB/18°CWB 79°FDB/64°FWB		27°CDB/19°CWB 81°FDB/66°FWB		28°CDB/20°CWB 82°FDB/68°FWB		30°CDB/22°CWB 86°FDB/72°FWB		32°CDB/23°CWB 90°FDB/73°FWB	
	TC	PI	TC	PI	TC	PI	TC	PI	TC	PI	TC	PI	TC	PI		
22.8 (150%)	10	50	16.3	2.11	17.9	2.40	21.2	3.06	22.8	3.44	24.5	3.92	27.5	4.93	28.1	4.96
	15	59	16.3	2.59	17.9	2.96	21.2	3.79	22.8	4.30	24.5	4.87	26.3	5.36	26.7	5.36
	21	70	16.3	3.24	17.9	3.70	21.2	4.77	22.7	5.36	23.1	5.36	23.9	5.36	24.4	5.36
	23	73	16.3	3.49	17.9	3.96	21.2	5.15	21.9	5.36	22.4	5.36	23.2	5.36	23.6	5.36
	25	77	16.3	3.74	17.9	4.27	20.8	5.36	21.2	5.36	21.6	5.36	22.5	5.36	22.9	5.36
	27	81	16.3	3.98	17.9	4.59	20.1	5.36	20.5	5.36	20.9	5.36	21.7	5.36	22.2	5.36
	30	86	16.3	4.43	17.9	5.11	19.1	5.36	19.5	5.36	19.9	5.36	20.7	5.36	21.1	5.36
	33	91	16.3	4.92	17.5	5.36	18.2	5.36	18.5	5.36	18.9	5.36	19.7	5.36	20.0	5.36
	35	95	16.3	5.27	16.8	5.36	17.5	5.36	17.9	5.36	18.3	5.36	19.0	5.36	19.3	5.36
	37	99	15.9	5.36	16.2	5.36	16.9	5.36	17.2	5.36	17.6	5.36	18.2	5.36	18.6	5.36
40	104	14.9	5.36	15.2	5.36	15.9	5.36	16.2	5.36	16.5	5.36	17.2	5.36	17.5	5.36	
43	109	13.6	5.13	13.9	5.13	14.5	5.13	14.8	5.13	15.1	5.13	15.7	5.13	16.1	5.13	
21.3 (140%)	10	50	15.2	1.94	16.7	2.18	19.7	2.74	21.3	3.09	22.8	3.44	25.9	4.37	26.6	4.48
	15	59	15.2	2.39	16.7	2.68	19.7	3.37	21.3	3.81	22.8	4.28	25.1	5.01	25.6	5.03
	21	70	15.2	2.98	16.7	3.36	19.7	4.24	21.3	4.83	22.7	5.36	23.5	5.36	23.9	5.36
	23	73	15.2	3.18	16.7	3.61	19.7	4.58	21.3	5.21	22.0	5.36	22.8	5.36	23.2	5.36
	25	77	15.2	3.41	16.7	3.86	19.7	4.92	20.9	5.36	21.3	5.36	22.1	5.36	22.5	5.36
	27	81	15.2	3.65	16.7	4.13	19.7	5.34	20.2	5.36	20.6	5.36	21.4	5.36	21.8	5.36
	30	86	15.2	4.02	16.7	4.59	18.8	5.36	19.2	5.36	19.6	5.36	20.3	5.36	20.7	5.36
	33	91	15.2	4.45	16.7	5.08	17.9	5.36	18.3	5.36	18.6	5.36	19.3	5.36	19.7	5.36
	35	95	15.2	4.75	16.6	5.36	17.3	5.36	17.6	5.36	18.0	5.36	18.7	5.36	19.0	5.36
	37	99	15.2	5.08	16.0	5.36	16.7	5.36	17.0	5.36	17.3	5.36	18.0	5.36	18.3	5.36
40	104	14.7	5.36	15.0	5.36	15.6	5.36	16.0	5.36	16.3	5.36	16.9	5.36	17.3	5.36	
43	109	13.4	5.13	13.7	5.13	14.3	5.13	14.6	5.13	14.9	5.13	15.5	5.13	15.8	5.13	
19.8 (130%)	10	50	14.1	1.81	15.5	1.98	18.4	2.47	19.8	2.74	21.2	3.06	24.1	3.81	25.0	4.03
	15	59	14.1	2.18	15.5	2.44	18.4	3.06	19.8	3.38	21.2	3.78	23.7	4.53	24.1	4.55
	21	70	14.1	2.72	15.5	3.05	18.4	3.84	19.8	4.28	21.2	4.77	22.6	5.12	23.0	5.15
	23	73	14.1	2.92	15.5	3.27	18.4	4.11	19.8	4.60	21.2	5.18	22.2	5.32	22.7	5.34
	25	77	14.1	3.11	15.5	3.50	18.4	4.44	19.8	4.94	20.8	5.36	21.6	5.36	22.0	5.36
	27	81	14.1	3.33	15.5	3.76	18.4	4.76	19.8	5.35	20.2	5.36	21.0	5.36	21.3	5.36
	30	86	14.1	3.67	15.5	4.13	18.4	5.27	18.9	5.36	19.2	5.36	20.0	5.36	20.3	5.36
	33	91	14.1	4.02	15.5	4.56	17.6	5.36	17.9	5.36	18.3	5.36	19.0	5.36	19.3	5.36
	35	95	14.1	4.29	15.5	4.87	17.0	5.36	17.3	5.36	17.7	5.36	18.4	5.36	18.7	5.36
	37	99	14.1	4.58	15.5	5.23	16.4	5.36	16.7	5.36	17.0	5.36	17.7	5.36	18.0	5.36
40	104	14.1	5.12	14.8	5.36	15.4	5.36	15.7	5.36	16.0	5.36	16.7	5.36	17.0	5.36	
43	109	14.1	5.36	13.5	5.13	14.1	5.13	14.4	5.13	14.7	5.13	15.3	5.13	15.6	5.13	
18.2 (120%)	10	50	13.0	1.71	14.3	1.83	17.0	2.22	18.2	2.45	19.5	2.72	22.2	3.29	23.4	3.62
	15	59	13.0	2.00	14.3	2.22	17.0	2.73	18.2	3.00	19.5	3.34	22.2	4.08	22.6	4.10
	21	70	13.0	2.49	14.3	2.76	17.0	3.43	18.2	3.79	19.5	4.20	21.2	4.64	21.6	4.65
	23	73	13.0	2.66	14.3	2.97	17.0	3.69	18.2	4.08	19.5	4.51	20.9	4.82	21.3	4.84
	25	77	13.0	2.84	14.3	3.17	17.0	3.96	18.2	4.37	19.5	4.88	20.5	4.99	20.9	5.01
	27	81	13.0	3.04	14.3	3.39	17.0	4.24	18.2	4.68	19.4	5.13	20.2	5.17	20.6	5.19
	30	86	13.0	3.33	14.3	3.74	17.0	4.68	18.2	5.21	18.8	5.36	19.5	5.36	19.9	5.36
	33	91	13.0	3.67	14.3	4.10	17.0	5.20	17.6	5.36	17.9	5.36	18.6	5.36	18.9	5.36
	35	95	13.0	3.90	14.3	4.41	16.6	5.36	17.0	5.36	17.3	5.36	18.0	5.36	18.3	5.36
	37	99	13.0	4.13	14.3	4.69	16.1	5.36	16.4	5.36	16.7	5.36	17.3	5.36	17.7	5.36
40	104	13.0	4.58	14.3	5.24	15.1	5.36	15.4	5.36	15.7	5.36	16.3	5.36	16.7	5.36	
43	109	13.0	5.13	13.3	5.13	13.9	5.13	14.1	5.13	14.4	5.13	15.0	5.13	15.3	5.13	
16.7 (110%)	10	50	11.9	1.62	13.1	1.72	15.5	1.99	16.7	2.18	17.9	2.40	20.3	2.85	21.5	3.14
	15	59	11.9	1.83	13.1	2.02	15.5	2.44	16.7	2.69	17.9	2.95	20.3	3.51	21.1	3.68
	21	70	11.9	2.26	13.1	2.51	15.5	3.06	16.7	3.37	17.9	3.70	19.7	4.18	20.1	4.20
	23	73	11.9	2.43	13.1	2.69	15.5	3.28	16.7	3.62	17.9	3.97	19.4	4.35	19.8	4.37
	25	77	11.9	2.59	13.1	2.87	15.5	3.51	16.7	3.88	17.9	4.25	19.1	4.52	19.5	4.53
	27	81	11.9	2.76	13.1	3.06	15.5	3.75	16.7	4.14	17.9	4.58	18.8	4.68	19.2	4.70
	30	86	11.9	3.02	13.1	3.38	15.5	4.15	16.7	4.60	17.6	4.88	18.3	4.92	18.7	4.94
	33	91	11.9	3.32	13.1	3.69	15.5	4.56	16.7	5.10	17.1	5.12	17.8	5.15	18.2	5.17
	35	95	11.9	3.52	13.1	3.93	15.5	4.89	16.4	5.25	16.8	5.27	17.5	5.31	17.9	5.33
	37	99	11.9	3.73	13.1	4.20	15.5	5.23	16.0	5.36	16.4	5.36	17.0	5.36	17.3	5.36
40	104	11.9	4.10	13.1	4.61	14.8	5.36	15.1	5.36	15.4	5.36	16.0	5.36	16.3	5.36	
43	109	11.9	4.56	13.0	5.13	13.6	5.13	13.9	5.13	14.2	5.13	14.7	5.13	15.0	5.13	

TC : Total Capacity kW

PI : Power Input kW (Comp. + Outdoor fan motor)

The data is based on the following conditions. Pipe length : 7.5m ; Height difference : 0 m.

COOLING CAPACITY

COOLING CAPACITY 20A

- MODELS : AJ*A54L, AJ*A54J, AO*54U , AO*54F

Total Capacity of Indoor Unit (kW)	Outdoor Temperature (°CDB) (°FDB)		Indoor Temperature													
			20°CDB/15°CWB		23°CDB/16°CWB		26°CDB/18°CWB		27°CDB/19°CWB		28°CDB/20°CWB		30°CDB/22°CWB		32°CDB/23°CWB	
			TC	PI	TC	PI	TC	PI	TC	PI	TC	PI	TC	PI	TC	PI
22.8 (150%)	10	50	16.3	2.11	17.9	2.40	21.2	3.06	22.8	3.44	24.5	3.92	26.0	4.19	26.5	4.19
	15	59	16.3	2.59	17.9	2.96	21.2	3.79	22.6	4.19	23.0	4.19	23.9	4.19	24.4	4.19
	21	70	16.3	3.24	17.9	3.70	19.9	4.19	20.3	4.19	20.7	4.19	21.5	4.19	21.9	4.19
	23	73	16.3	3.49	17.9	3.96	19.2	4.19	19.6	4.19	20.0	4.19	20.8	4.19	21.2	4.19
	25	77	16.3	3.74	17.7	4.19	18.5	4.19	18.9	4.19	19.3	4.19	20.0	4.19	20.4	4.19
	27	81	16.3	3.98	17.1	4.19	17.8	4.19	18.2	4.19	18.5	4.19	19.3	4.19	19.7	4.19
	30	86	15.8	4.19	16.1	4.19	16.8	4.19	17.2	4.19	17.5	4.19	18.2	4.19	18.6	4.19
	33	91	14.9	4.19	15.2	4.19	15.9	4.19	16.2	4.19	16.5	4.19	17.2	4.19	17.6	4.19
	35	95	14.3	4.19	14.6	4.19	15.2	4.19	15.6	4.19	15.9	4.19	16.6	4.19	16.9	4.19
	37	99	13.7	4.19	14.0	4.19	14.6	4.19	15.0	4.19	15.3	4.19	15.9	4.19	16.2	4.19
40	104	12.9	4.19	13.2	4.19	13.7	4.19	14.0	4.19	14.3	4.19	14.9	4.19	15.2	4.19	
43	109	12.0	4.19	12.2	4.19	12.8	4.19	13.1	4.19	13.3	4.19	13.9	4.19	14.2	4.19	
21.3 (140%)	10	50	15.2	1.94	16.7	2.18	19.7	2.74	21.3	3.09	22.8	3.44	25.5	4.19	26.0	4.19
	15	59	15.2	2.39	16.7	2.68	19.7	3.37	21.3	3.81	22.6	4.19	23.5	4.19	23.9	4.19
	21	70	15.2	2.98	16.7	3.36	19.6	4.19	20.0	4.19	20.4	4.19	21.1	4.19	21.5	4.19
	23	73	15.2	3.18	16.7	3.60	18.9	4.19	19.3	4.19	19.6	4.19	20.4	4.19	20.8	4.19
	25	77	15.2	3.41	16.7	3.86	18.2	4.19	18.6	4.19	18.9	4.19	19.7	4.19	20.1	4.19
	27	81	15.2	3.65	16.7	4.13	17.5	4.19	17.9	4.19	18.3	4.19	19.0	4.19	19.3	4.19
	30	86	15.2	4.02	15.9	4.19	16.6	4.19	16.9	4.19	17.3	4.19	18.0	4.19	18.3	4.19
	33	91	14.7	4.19	15.0	4.19	15.6	4.19	16.0	4.19	16.3	4.19	17.0	4.19	17.3	4.19
	35	95	14.1	4.19	14.4	4.19	15.0	4.19	15.4	4.19	15.7	4.19	16.3	4.19	16.6	4.19
	37	99	13.5	4.19	13.8	4.19	14.5	4.19	14.8	4.19	15.1	4.19	15.7	4.19	16.0	4.19
40	104	12.7	4.19	13.0	4.19	13.6	4.19	13.8	4.19	14.1	4.19	14.7	4.19	15.0	4.19	
43	109	11.8	4.19	12.1	4.19	12.6	4.19	12.9	4.19	13.2	4.19	13.7	4.19	14.0	4.19	
19.8 (130%)	10	50	14.1	1.81	15.5	1.98	18.4	2.47	19.8	2.74	21.2	3.06	24.1	3.81	25.0	4.03
	15	59	14.1	2.18	15.5	2.44	18.4	3.06	19.8	3.38	21.2	3.78	23.0	4.19	23.4	4.19
	21	70	14.1	2.72	15.5	3.05	18.4	3.84	19.6	4.19	20.0	4.19	20.7	4.19	21.1	4.19
	23	73	14.1	2.92	15.5	3.27	18.4	4.11	18.9	4.19	19.3	4.19	20.0	4.19	20.4	4.19
	25	77	14.1	3.11	15.5	3.50	17.9	4.19	18.2	4.19	18.6	4.19	19.3	4.19	19.7	4.19
	27	81	14.1	3.33	15.5	3.76	17.2	4.19	17.6	4.19	17.9	4.19	18.6	4.19	19.0	4.19
	30	86	14.1	3.67	15.5	4.13	16.3	4.19	16.6	4.19	17.0	4.19	17.6	4.19	18.0	4.19
	33	91	14.1	4.02	14.7	4.19	15.4	4.19	15.7	4.19	16.0	4.19	16.7	4.19	17.0	4.19
	35	95	13.9	4.19	14.2	4.19	14.8	4.19	15.1	4.19	15.4	4.19	16.1	4.19	16.4	4.19
	37	99	13.3	4.19	13.6	4.19	14.2	4.19	14.5	4.19	14.8	4.19	15.4	4.19	15.8	4.19
40	104	12.6	4.19	12.8	4.19	13.4	4.19	13.7	4.19	13.9	4.19	14.5	4.19	14.8	4.19	
43	109	11.7	4.19	11.9	4.19	12.5	4.19	12.7	4.19	13.0	4.19	13.5	4.19	13.8	4.19	
18.2 (120%)	10	50	13.0	1.71	14.3	1.83	17.0	2.22	18.2	2.45	19.5	2.72	22.2	3.29	23.4	3.62
	15	59	13.0	2.00	14.3	2.22	17.0	2.73	18.2	3.00	19.5	3.34	22.2	4.08	22.6	4.10
	21	70	13.0	2.49	14.3	2.76	17.0	3.43	18.2	3.79	19.5	4.19	20.3	4.19	20.6	4.19
	23	73	13.0	2.66	14.3	2.97	17.0	3.69	18.2	4.08	18.8	4.19	19.6	4.19	19.9	4.19
	25	77	13.0	2.84	14.3	3.17	17.0	3.95	17.8	4.19	18.2	4.19	18.9	4.19	19.3	4.19
	27	81	13.0	3.04	14.3	3.39	17.0	4.19	17.2	4.19	17.6	4.19	18.3	4.19	18.6	4.19
	30	86	13.0	3.33	14.3	3.74	16.0	4.19	16.3	4.19	16.6	4.19	17.3	4.19	17.6	4.19
	33	91	13.0	3.67	14.3	4.10	15.1	4.19	15.4	4.19	15.7	4.19	16.4	4.19	16.7	4.19
	35	95	13.0	3.90	13.9	4.19	14.5	4.19	14.8	4.19	15.1	4.19	15.8	4.19	16.1	4.19
	37	99	13.0	4.13	13.4	4.19	14.0	4.19	14.3	4.19	14.6	4.19	15.2	4.19	15.5	4.19
40	104	12.4	4.19	12.6	4.19	13.2	4.19	13.4	4.19	13.7	4.19	14.3	4.19	14.5	4.19	
43	109	11.5	4.19	11.8	4.19	12.3	4.19	12.5	4.19	12.8	4.19	13.3	4.19	13.6	4.19	
16.7 (110%)	10	50	11.9	1.62	13.1	1.72	15.5	1.99	16.7	2.18	17.9	2.40	20.3	2.85	21.5	3.14
	15	59	11.9	1.83	13.1	2.02	15.5	2.44	16.7	2.69	17.9	2.95	20.3	3.51	21.1	3.68
	21	70	11.9	2.26	13.1	2.51	15.5	3.06	16.7	3.37	17.9	3.70	19.7	4.18	20.1	4.19
	23	73	11.9	2.43	13.1	2.69	15.5	3.28	16.7	3.62	17.9	3.97	19.1	4.19	19.4	4.19
	25	77	11.9	2.59	13.1	2.87	15.5	3.51	16.7	3.88	17.8	4.19	18.4	4.19	18.8	4.19
	27	81	11.9	2.76	13.1	3.06	15.5	3.75	16.7	4.14	17.1	4.19	17.8	4.19	18.2	4.19
	30	86	11.9	3.02	13.1	3.38	15.5	4.15	15.9	4.19	16.3	4.19	16.9	4.19	17.2	4.19
	33	91	11.9	3.32	13.1	3.69	14.8	4.19	15.1	4.19	15.4	4.19	16.0	4.19	16.3	4.19
	35	95	11.9	3.52	13.1	3.93	14.2	4.19	14.5	4.19	14.8	4.19	15.4	4.19	15.7	4.19
	37	99	11.9	3.73	13.1	4.19	13.7	4.19	14.0	4.19	14.3	4.19	14.9	4.19	15.2	4.19
40	104	11.9	4.10	12.4	4.19	12.9	4.19	13.2	4.19	13.4	4.19	14.0	4.19	14.3	4.19	
43	109	11.3	4.19	11.6	4.19	12.1	4.19	12.3	4.19	12.6	4.19	13.1	4.19	13.3	4.19	

TC : Total Capacity kW

PI : Power Input kW (Comp. + Outdoor fan motor)

The data is based on the following conditions. Pipe length : 7.5m ; Height difference : 0 m.

COOLING CAPACITY 15A

■ COOLING CAPACITY

- MODELS : AJ*A54L, AJ*A54J, AO*54U , AO*54F

Total Capacity of Indoor Unit (kW)	Outdoor Temperature		Indoor Temperature													
			20°CDB/15°CWB		23°CDB/16°CWB		26°CDB/18°CWB		27°CDB/19°CWB		28°CDB/20°CWB		30°CDB/22°CWB		32°CDB/23°CWB	
	(°CDB)	(°FDB)	TC	PI	TC	PI	TC	PI	TC	PI	TC	PI	TC	PI	TC	PI
22.8 (150%)	10	50	16.3	2.11	17.9	2.40	21.0	3.01	21.5	3.01	21.9	3.01	22.8	3.01	23.2	3.01
	15	59	16.3	2.59	17.9	2.96	18.9	3.01	19.3	3.01	19.7	3.01	20.6	3.01	21.0	3.01
	21	70	15.6	3.01	15.9	3.01	16.6	3.01	17.0	3.01	17.4	3.01	18.1	3.01	18.5	3.01
	23	73	14.9	3.01	15.2	3.01	15.9	3.01	16.3	3.01	16.6	3.01	17.3	3.01	17.7	3.01
	25	77	14.2	3.01	14.5	3.01	15.2	3.01	15.6	3.01	15.9	3.01	16.6	3.01	16.9	3.01
	27	81	13.6	3.01	13.9	3.01	14.5	3.01	14.9	3.01	15.2	3.01	15.9	3.01	16.2	3.01
	30	86	12.7	3.01	13.0	3.01	13.6	3.01	13.9	3.01	14.2	3.01	14.8	3.01	15.2	3.01
	33	91	11.8	3.01	12.1	3.01	12.7	3.01	13.0	3.01	13.3	3.01	13.8	3.01	14.1	3.01
	35	95	11.3	3.01	11.5	3.01	12.1	3.01	12.4	3.01	12.7	3.01	13.2	3.01	13.5	3.01
	37	99	10.8	3.01	11.0	3.01	11.5	3.01	11.8	3.01	12.1	3.01	12.6	3.01	12.9	3.01
	40	104	10.0	3.01	10.2	3.01	10.7	3.01	11.0	3.01	11.2	3.01	11.7	3.01	12.0	3.01
43	109	9.29	3.01	9.51	3.01	9.95	3.01	10.2	3.01	10.4	3.01	10.9	3.01	11.1	3.01	
21.3 (140%)	10	50	15.2	1.95	16.7	2.18	19.7	2.74	21.1	3.01	21.5	3.01	22.3	3.01	22.8	3.01
	15	59	15.2	2.39	16.7	2.68	18.6	3.01	19.0	3.01	19.4	3.01	20.2	3.01	20.6	3.01
	21	70	15.2	2.98	15.7	3.01	16.4	3.01	16.7	3.01	17.1	3.01	17.8	3.01	18.2	3.01
	23	73	14.7	3.01	15.0	3.01	15.7	3.01	16.0	3.01	16.4	3.01	17.1	3.01	17.4	3.01
	25	77	14.0	3.01	14.3	3.01	15.0	3.01	15.3	3.01	15.7	3.01	16.3	3.01	16.7	3.01
	27	81	13.4	3.01	13.7	3.01	14.3	3.01	14.7	3.01	15.0	3.01	15.6	3.01	16.0	3.01
	30	86	12.5	3.01	12.8	3.01	13.4	3.01	13.7	3.01	14.0	3.01	14.6	3.01	14.9	3.01
	33	91	11.7	3.01	12.0	3.01	12.5	3.01	12.8	3.01	13.1	3.01	13.7	3.01	14.0	3.01
	35	95	11.1	3.01	11.4	3.01	12.0	3.01	12.2	3.01	12.5	3.01	13.1	3.01	13.3	3.01
	37	99	10.6	3.01	10.9	3.01	11.4	3.01	11.7	3.01	11.9	3.01	12.5	3.01	12.7	3.01
	40	104	9.90	3.01	10.1	3.01	10.6	3.01	10.9	3.01	11.1	3.01	11.6	3.01	11.9	3.01
43	109	9.20	3.01	9.42	3.01	9.85	3.01	10.1	3.01	10.3	3.01	10.8	3.01	11.0	3.01	
19.8 (130%)	10	50	14.1	1.81	15.5	1.98	18.4	2.47	19.8	2.74	21.0	3.01	21.9	3.01	22.3	3.01
	15	59	14.1	2.18	15.5	2.44	18.3	3.01	18.6	3.01	19.0	3.01	19.8	3.01	20.2	3.01
	21	70	14.1	2.72	15.4	3.01	16.1	3.01	16.4	3.01	16.8	3.01	17.5	3.01	17.9	3.01
	23	73	14.1	2.92	14.7	3.01	15.4	3.01	15.7	3.01	16.1	3.01	16.8	3.01	17.1	3.01
	25	77	13.8	3.01	14.1	3.01	14.7	3.01	15.1	3.01	15.4	3.01	16.1	3.01	16.4	3.01
	27	81	13.2	3.01	13.5	3.01	14.1	3.01	14.4	3.01	14.7	3.01	15.4	3.01	15.7	3.01
	30	86	12.3	3.01	12.6	3.01	13.2	3.01	13.5	3.01	13.8	3.01	14.4	3.01	14.7	3.01
	33	91	11.5	3.01	11.8	3.01	12.3	3.01	12.6	3.01	12.9	3.01	13.5	3.01	13.8	3.01
	35	95	11.0	3.01	11.3	3.01	11.8	3.01	12.1	3.01	12.3	3.01	12.9	3.01	13.1	3.01
	37	99	10.5	3.01	10.8	3.01	11.3	3.01	11.5	3.01	11.8	3.01	12.3	3.01	12.6	3.01
	40	104	9.79	3.01	10.0	3.01	10.5	3.01	10.7	3.01	11.0	3.01	11.5	3.01	11.7	3.01
43	109	9.10	3.01	9.31	3.01	9.74	3.01	9.96	3.01	10.2	3.01	10.6	3.01	10.9	3.01	
18.2 (120%)	10	50	13.0	1.71	14.3	1.83	17.0	2.22	18.2	2.45	19.5	2.72	21.3	3.01	21.7	3.01
	15	59	13.0	2.00	14.3	2.22	17.0	2.73	18.2	3.00	18.6	3.01	19.3	3.01	19.7	3.01
	21	70	13.0	2.49	14.3	2.76	15.8	3.01	16.1	3.01	16.4	3.01	17.1	3.01	17.5	3.01
	23	73	13.0	2.66	14.3	2.97	15.1	3.01	15.4	3.01	15.8	3.01	16.4	3.01	16.8	3.01
	25	77	13.0	2.84	13.9	3.01	14.5	3.01	14.8	3.01	15.1	3.01	15.8	3.01	16.1	3.01
	27	81	13.0	3.01	13.3	3.01	13.9	3.01	14.2	3.01	14.5	3.01	15.1	3.01	15.4	3.01
	30	86	12.1	3.01	12.4	3.01	13.0	3.01	13.3	3.01	13.6	3.01	14.2	3.01	14.4	3.01
	33	91	11.3	3.01	11.6	3.01	12.1	3.01	12.4	3.01	12.7	3.01	13.2	3.01	13.5	3.01
	35	95	10.8	3.01	11.1	3.01	11.6	3.01	11.9	3.01	12.1	3.01	12.7	3.01	12.9	3.01
	37	99	10.4	3.01	10.6	3.01	11.1	3.01	11.3	3.01	11.6	3.01	12.1	3.01	12.4	3.01
	40	104	9.65	3.01	9.88	3.01	10.3	3.01	10.6	3.01	10.8	3.01	11.3	3.01	11.5	3.01
43	109	8.99	3.01	9.20	3.01	9.62	3.01	9.84	3.01	10.1	3.01	10.5	3.01	10.7	3.01	
16.7 (110%)	10	50	11.9	1.62	13.1	1.72	15.5	1.99	16.7	2.18	17.9	2.40	20.3	2.85	21.1	3.01
	15	59	11.9	1.83	13.1	2.02	15.5	2.44	16.7	2.69	17.9	2.95	18.8	3.01	19.2	3.01
	21	70	11.9	2.26	13.1	2.51	15.4	3.01	15.7	3.01	16.1	3.01	16.7	3.01	17.1	3.01
	23	73	11.9	2.43	13.1	2.69	14.8	3.01	15.1	3.01	15.4	3.01	16.1	3.01	16.4	3.01
	25	77	11.9	2.59	13.1	2.87	14.2	3.01	14.5	3.01	14.8	3.01	15.4	3.01	15.7	3.01
	27	81	11.9	2.76	13.0	3.01	13.6	3.01	13.9	3.01	14.2	3.01	14.8	3.01	15.1	3.01
	30	86	11.9	3.01	12.2	3.01	12.7	3.01	13.0	3.01	13.3	3.01	13.9	3.01	14.2	3.01
	33	91	11.1	3.01	11.4	3.01	11.9	3.01	12.2	3.01	12.5	3.01	13.0	3.01	13.3	3.01
	35	95	10.6	3.01	10.9	3.01	11.4	3.01	11.7	3.01	11.9	3.01	12.4	3.01	12.7	3.01
	37	99	10.2	3.01	10.4	3.01	10.9	3.01	11.1	3.01	11.4	3.01	11.9	3.01	12.1	3.01
	40	104	9.50	3.01	9.73	3.01	10.2	3.01	10.4	3.01	10.6	3.01	11.1	3.01	11.3	3.01
43	109	8.86	3.01	9.06	3.01	9.48	3.01	9.69	3.01	9.90	3.01	10.3	3.01	10.6	3.01	

TC : Total Capacity kW

PI : Power Input kW (Comp. + Outdoor fan motor)

The data is based on the following conditions. Pipe length : 7.5m ; Height difference : 0 m.

COOLING CAPACITY 15A

■ COOLING CAPACITY

• MODELS : AJ*A54L, AJ*A54J, AO*54U , AO*54F

Total Capacity of Indoor Unit (kW)	Outdoor Temperature (°CDB) (°FDB)		Indoor Temperature													
			20°CDB/15°CWB		23°CDB/16°CWB		26°CDB/18°CWB		27°CDB/19°CWB		28°CDB/20°CWB		30°CDB/22°CWB		32°CDB/23°CWB	
			68°FDB/59°FWB	PI	73°FDB/61°FWB	PI	79°FDB/64°FWB	PI	81°FDB/66°FWB	PI	82°FDB/68°FWB	PI	86°FDB/72°FWB	PI	90°FDB/73°FWB	PI
15.2 (100%)	10	50	10.8	1.52	11.9	1.62	14.1	1.81	15.2	1.94	16.3	2.11	18.5	2.49	19.5	2.69
	15	59	10.8	1.67	11.9	1.83	14.1	2.18	15.2	2.38	16.3	2.60	18.3	3.01	18.6	3.01
	21	70	10.8	2.06	11.9	2.27	14.1	2.73	15.2	2.97	16.3	3.01	16.3	3.01	16.6	3.01
	23	73	10.8	2.20	11.9	2.43	14.1	2.90	14.7	3.01	15.0	3.01	15.6	3.01	15.9	3.01
	25	77	10.8	2.35	11.9	2.58	13.8	3.01	14.1	3.01	14.4	3.01	15.0	3.01	15.3	3.01
	27	81	10.8	2.50	11.9	2.76	13.3	3.01	13.5	3.01	13.8	3.01	14.4	3.01	14.7	3.01
	30	86	10.8	2.73	11.9	3.01	12.4	3.01	12.7	3.01	13.0	3.01	13.5	3.01	13.8	3.01
	33	91	10.8	3.00	11.2	3.01	11.7	3.01	11.9	3.01	12.2	3.01	12.7	3.01	13.0	3.01
	35	95	10.4	3.01	10.7	3.01	11.2	3.01	11.4	3.01	11.7	3.01	12.2	3.01	12.4	3.01
	37	99	9.98	3.01	10.2	3.01	10.7	3.01	10.9	3.01	11.2	3.01	11.6	3.01	11.9	3.01
40	104	9.33	3.01	9.55	3.01	9.99	3.01	10.2	3.01	10.4	3.01	10.9	3.01	11.1	3.01	
43	109	8.71	3.01	8.91	3.01	9.32	3.01	9.52	3.01	9.73	3.01	10.1	3.01	10.4	3.01	
13.7 (90%)	10	50	9.78	1.43	10.7	1.51	12.7	1.69	13.7	1.77	14.6	1.86	16.6	2.15	17.6	2.34
	15	59	9.78	1.52	10.7	1.65	12.7	1.95	13.7	2.11	14.6	2.28	16.6	2.65	17.6	2.87
	21	70	9.78	1.87	10.7	2.04	12.7	2.42	13.7	2.63	14.6	2.85	15.8	3.01	16.1	3.01
	23	73	9.78	2.00	10.7	2.18	12.7	2.59	13.7	2.82	14.6	3.01	15.1	3.01	15.5	3.01
	25	77	9.78	2.13	10.7	2.33	12.7	2.77	13.7	3.01	14.0	3.01	14.6	3.01	14.9	3.01
	27	81	9.78	2.26	10.7	2.47	12.7	2.96	13.2	3.01	13.4	3.01	14.0	3.01	14.3	3.01
	30	86	9.78	2.48	10.7	2.71	12.1	3.01	12.4	3.01	12.6	3.01	13.2	3.01	13.4	3.01
	33	91	9.78	2.70	10.7	2.97	11.4	3.01	11.6	3.01	11.9	3.01	12.4	3.01	12.6	3.01
	35	95	9.78	2.86	10.4	3.01	10.9	3.01	11.1	3.01	11.4	3.01	11.9	3.01	12.1	3.01
	37	99	9.78	3.01	9.98	3.01	10.4	3.01	10.7	3.01	10.9	3.01	11.4	3.01	11.6	3.01
40	104	9.13	3.01	9.34	3.01	9.77	3.01	9.99	3.01	10.2	3.01	10.6	3.01	10.9	3.01	
43	109	8.53	3.01	8.73	3.01	9.13	3.01	9.33	3.01	9.53	3.01	9.94	3.01	10.1	3.01	
12.2 (80%)	10	50	8.69	1.33	9.55	1.41	11.3	1.56	12.2	1.64	13.0	1.72	14.8	1.87	15.7	2.01
	15	59	8.69	1.38	9.55	1.49	11.3	1.73	12.2	1.87	13.0	2.00	14.8	2.30	15.7	2.47
	21	70	8.69	1.69	9.55	1.83	11.3	2.14	12.2	2.31	13.0	2.49	14.8	2.87	15.5	3.01
	23	73	8.69	1.80	9.55	1.95	11.3	2.30	12.2	2.48	13.0	2.67	14.6	3.01	14.9	3.01
	25	77	8.69	1.92	9.55	2.08	11.3	2.45	12.2	2.64	13.0	2.84	14.0	3.01	14.3	3.01
	27	81	8.69	2.03	9.55	2.21	11.3	2.60	12.2	2.82	13.0	3.01	13.5	3.01	13.8	3.01
	30	86	8.69	2.22	9.55	2.42	11.3	2.86	12.0	3.01	12.2	3.01	12.7	3.01	13.0	3.01
	33	91	8.69	2.42	9.55	2.64	11.0	3.01	11.3	3.01	11.5	3.01	12.0	3.01	12.2	3.01
	35	95	8.69	2.56	9.55	2.79	10.6	3.01	10.8	3.01	11.0	3.01	11.5	3.01	11.7	3.01
	37	99	8.69	2.70	9.55	2.95	10.1	3.01	10.4	3.01	10.6	3.01	11.0	3.01	11.3	3.01
40	104	8.69	2.92	9.09	3.01	9.51	3.01	9.72	3.01	9.93	3.01	10.4	3.01	10.6	3.01	
43	109	8.32	3.01	8.51	3.01	8.90	3.01	9.09	3.01	9.29	3.01	9.68	3.01	9.88	3.01	
10.6 (70%)	10	50	7.60	1.24	8.37	1.30	9.88	1.43	10.6	1.50	11.4	1.57	12.9	1.71	13.7	1.78
	15	59	7.60	1.25	8.37	1.34	9.88	1.53	10.6	1.64	11.4	1.74	12.9	1.98	13.7	2.11
	21	70	7.60	1.52	8.37	1.64	9.88	1.89	10.6	2.02	11.4	2.16	12.9	2.46	13.7	2.62
	23	73	7.60	1.62	8.37	1.74	9.88	2.02	10.6	2.16	11.4	2.31	12.9	2.63	13.6	2.79
	25	77	7.60	1.72	8.37	1.86	9.88	2.15	10.6	2.30	11.4	2.46	12.9	2.81	13.4	2.90
	27	81	7.60	1.82	8.37	1.97	9.88	2.29	10.6	2.45	11.4	2.62	12.9	3.01	13.2	3.01
	30	86	7.60	1.98	8.37	2.15	9.88	2.50	10.6	2.68	11.4	2.88	12.2	3.01	12.5	3.01
	33	91	7.60	2.15	8.37	2.34	9.88	2.72	10.6	2.93	11.1	3.01	11.5	3.01	11.8	3.01
	35	95	7.60	2.27	8.37	2.46	9.88	2.89	10.4	3.01	10.6	3.01	11.1	3.01	11.3	3.01
	37	99	7.60	2.39	8.37	2.61	9.78	3.01	9.99	3.01	10.2	3.01	10.6	3.01	10.9	3.01
40	104	7.60	2.59	8.37	2.83	9.19	3.01	9.39	3.01	9.59	3.01	10.0	3.01	10.2	3.01	
43	109	7.60	2.81	8.25	3.01	8.63	3.01	8.81	3.01	9.00	3.01	9.38	3.01	9.57	3.01	
9.1 (60%)	10	50	6.52	1.14	7.17	1.20	8.46	1.31	9.12	1.37	9.78	1.43	11.1	1.54	11.7	1.60
	15	59	6.52	1.24	7.17	1.32	8.46	1.47	9.12	1.55	9.78	1.63	11.1	1.79	11.7	1.88
	21	70	6.52	1.36	7.17	1.46	8.46	1.66	9.12	1.76	9.78	1.87	11.1	2.10	11.7	2.23
	23	73	6.52	1.45	7.17	1.55	8.46	1.76	9.12	1.88	9.78	2.00	11.1	2.25	11.7	2.37
	25	77	6.52	1.53	7.17	1.64	8.46	1.87	9.12	2.00	9.78	2.12	11.1	2.39	11.7	2.54
	27	81	6.52	1.62	7.17	1.74	8.46	1.99	9.12	2.12	9.78	2.26	11.1	2.55	11.6	2.66
	30	86	6.52	1.76	7.17	1.89	8.46	2.17	9.12	2.31	9.78	2.47	11.1	2.80	11.3	2.81
	33	91	6.52	1.90	7.17	2.05	8.46	2.36	9.12	2.52	9.78	2.70	10.8	2.95	11.1	2.96
	35	95	6.52	2.01	7.17	2.16	8.46	2.49	9.12	2.67	9.78	2.85	10.6	3.01	10.8	3.01
	37	99	6.52	2.11	7.17	2.28	8.46	2.63	9.12	2.83	9.78	3.01	10.2	3.01	10.4	3.01
40	104	6.52	2.28	7.17	2.47	8.46	2.85	9.00	3.01	9.19	3.01	9.57	3.01	9.77	3.01	
43	109	6.52	2.45	7.17	2.66	8.29	3.01	8.47	3.01	8.65	3.01	9.01	3.01	9.19	3.01	
7.6 (50%)	10	50	5.43	1.05	5.97	1.10	7.05	1.19	7.60	1.24	8.14	1.29	9.22	1.38	9.78	1.43
	15	59	5.43	1.13	5.97	1.18	7.05	1.30	7.60	1.37	8.14	1.43	9.22	1.56	9.78	1.63
	21	70	5.43	1.21	5.97	1.29	7.05	1.44	7.60	1.52	8.14	1.60	9.22	1.78	9.78	1.87
	23	73	5.43	1.28	5.97	1.36	7.05	1.53	7.60	1.62	8.14	1.71	9.22	1.90	9.78	2.00
	25	77	5.43	1.36	5.97	1.44	7.05	1.62	7.60	1.72	8.14	1.81	9.22	2.02	9.78	2.13
	27	81	5.43	1.43	5.97	1.52	7.05	1.71	7.60	1.82	8.14	1.92	9.22	2.15	9.78	2.26
	30	86	5.43	1.55	5.97	1.65	7.05	1.87	7.60	1.98	8.14	2.10	9.22	2.34	9.73	2.45
	33	91	5.43	1.67	5.97	1.78	7.05	2.02	7.60	2.15	8.14	2.28	9.22	2.55	9.49	2.58
	35	95	5.43	1.75	5.97	1.88	7.05	2.13	7.60	2.27	8.14	2.41	9.14	2.67	9.34	2.67
	37	99	5.43	1.84	5.97	1.97	7.05	2.25	7.60	2.40	8.14	2.54	8.98	2.75	9.18	2.75
40	104	5.43	1.98	5.97	2.12	7.05	2.43	7.60	2.59	8.14	2.75	8.74	2.87	8.93	2.88	
43	109	5.43	2.13	5.97	2.28	7.05	2.62	7.60	2.80	8.14	2.98	8.49	2.99	8.68	3.00	

TC : Total Capacity kW

PI : Power Input kW (Comp. + Outdoor fan motor)

The data is based on the following conditions. Pipe length : 7.5m ; Height difference : 0 m.

HEATING CAPACITY 30A

■ HEATING CAPACITY

• MODELS : AJ*A54L, AO*54U

Total Capacity of Indoor Unit (kW)	Outdoor Temperature			Indoor Temperature											
				15°CDB 59°FDB		18°CDB 64°FDB		20°CDB 68°FDB		23°CDB 73°FDB		25°CDB 77°FDB		27°CDB 81°FDB	
	(°CDB)	(°FDB)	RH	TC	PI	TC	PI	TC	PI	TC	PI	TC	PI	TC	PI
22.8 (150%)	-20	-4	RH85%	11.7	3.89	11.3	4.29	10.8	4.52	10.2	4.85	9.79	5.06	9.42	5.24
	-15	5		13.4	4.45	13.1	4.83	12.7	5.03	12.1	5.33	11.7	5.39	11.3	5.39
	-10	14		15.2	4.91	14.7	5.24	14.3	5.42	13.7	5.48	13.3	5.48	12.9	5.48
	-5	23		16.9	5.27	16.5	5.53	16.1	5.56	15.4	5.56	15.0	5.56	14.6	5.56
	0	32		18.2	5.44	17.7	5.49	17.5	5.52	17.0	5.57	16.7	5.60	16.4	5.62
	5	41		19.1	5.34	18.6	5.39	18.4	5.42	17.9	5.47	17.7	5.50	17.4	5.53
	7	45		19.5	5.30	19.0	5.35	18.7	5.38	18.3	5.42	18.0	5.45	17.4	5.26
	10	50		19.5	4.85	19.0	4.90	18.7	4.92	18.3	4.97	18.0	5.00	17.4	4.87
15	59	20.3	4.77	19.9	4.81	19.6	4.84	19.2	4.88	18.6	4.76	17.4	4.29		
21.3 (140%)	-20	-4	RH85%	11.7	4.03	11.1	4.39	10.7	4.61	10.0	4.94	9.66	5.15	9.30	5.24
	-15	5		13.4	4.58	12.9	4.93	12.5	5.13	11.9	5.39	11.5	5.40	11.1	5.39
	-10	14		15.2	5.05	14.5	5.34	14.1	5.48	13.5	5.48	13.1	5.48	12.7	5.48
	-5	23		16.9	5.40	16.3	5.55	15.8	5.56	15.2	5.56	14.8	5.56	14.4	5.56
	0	32		18.1	5.48	17.7	5.52	17.3	5.55	16.9	5.59	16.6	5.62	16.2	5.62
	5	41		19.1	5.39	18.7	5.43	18.3	5.46	17.9	5.50	17.6	5.53	16.7	5.22
	7	45		19.6	5.35	19.1	5.40	18.8	5.42	18.3	5.46	18.0	5.49	16.7	4.93
	10	50		19.6	4.90	19.1	4.94	18.8	4.96	18.3	5.00	18.0	5.03	16.7	4.56
15	59	20.6	4.82	20.1	4.86	19.7	4.89	19.2	4.92	18.0	4.47	16.7	4.04		
19.8 (130%)	-20	-4	RH85%	11.6	4.16	10.9	4.50	10.5	4.72	9.88	5.04	9.52	5.24	9.17	5.24
	-15	5		13.4	4.73	12.7	5.04	12.3	5.24	11.7	5.39	11.3	5.39	11.0	5.39
	-10	14		14.9	5.17	14.2	5.45	13.8	5.48	13.2	5.48	12.9	5.48	12.5	5.48
	-5	23		16.6	5.54	16.0	5.56	15.6	5.56	15.0	5.56	14.6	5.56	14.2	5.56
	0	32		18.0	5.52	17.5	5.55	17.2	5.58	16.7	5.61	16.3	5.62	15.5	5.38
	5	41		19.1	5.45	18.6	5.48	18.3	5.50	17.8	5.54	17.1	5.39	15.5	4.77
	7	45		19.6	5.42	19.0	5.45	18.7	5.47	18.2	5.51	17.1	5.07	15.5	4.53
	10	50		19.6	4.96	19.0	4.99	18.7	5.01	18.2	5.04	17.1	4.74	15.5	4.20
15	59	20.7	4.89	20.1	4.92	19.8	4.94	18.5	4.59	17.1	4.16	15.5	3.74		
18.2 (120%)	-20	-4	RH85%	11.3	4.29	10.7	4.62	10.3	4.84	9.71	5.16	9.36	5.24	9.03	5.24
	-15	5		13.1	4.87	12.4	5.17	12.1	5.36	11.5	5.39	11.1	5.39	10.8	5.40
	-10	14		14.6	5.31	14.0	5.48	13.6	5.48	13.0	5.48	12.6	5.48	12.3	5.48
	-5	23		16.3	5.55	15.7	5.56	15.3	5.56	14.7	5.56	14.3	5.56	13.9	5.56
	0	32		17.8	5.56	17.3	5.59	16.9	5.60	16.4	5.62	15.9	5.61	14.3	4.95
	5	41		19.0	5.51	18.5	5.53	18.1	5.55	17.4	5.49	15.9	4.90	14.3	4.35
	7	45		19.5	5.48	18.9	5.51	18.5	5.53	17.4	5.17	15.9	4.65	14.3	4.13
	10	50		19.5	5.02	18.9	5.04	18.5	5.06	17.4	4.82	15.9	4.33	14.3	3.85
15	59	20.7	4.97	20.1	4.99	19.4	4.85	17.4	4.24	15.9	3.84	14.3	3.42		
16.7 (110%)	-20	-4	RH85%	11.1	4.44	10.4	4.77	10.1	4.99	9.52	5.24	9.18	5.24	8.87	5.24
	-15	5		12.8	5.02	12.2	5.32	11.8	5.39	11.3	5.39	10.9	5.39	10.6	5.39
	-10	14		14.2	5.47	13.7	5.48	13.3	5.48	12.7	5.48	12.4	5.48	12.1	5.48
	-5	23		15.9	5.56	15.3	5.56	14.9	5.56	14.4	5.56	14.0	5.56	13.1	5.05
	0	32		17.5	5.60	17.0	5.61	16.6	5.62	16.1	5.62	14.6	5.04	13.1	4.47
	5	41		18.8	5.57	18.2	5.58	17.8	5.59	16.1	4.98	14.6	4.44	13.1	3.96
	7	45		19.3	5.55	18.7	5.57	18.2	5.44	16.1	4.69	14.6	4.20	13.1	3.76
	10	50		19.3	5.08	18.7	5.09	18.2	5.06	16.1	4.36	14.6	3.94	13.1	3.52
15	59	20.6	5.05	19.5	4.86	18.2	4.46	16.1	3.87	14.6	3.49	13.1	3.14		

TC : Total Capacity kW

PI : Power Input kW (Comp. + Outdoor fan motor)

The data is based on the following conditions. Pipe length : 7.5m ; Height difference : 0 m.

HEATING CAPACITY 30A

■ HEATING CAPACITY

• MODELS : AJ*A54L, AO*54U

Total Capacity of Indoor Unit (kW)	Outdoor Temperature			Indoor Temperature											
				15°CDB		18°CDB		20°CDB		23°CDB		25°CDB		27°CDB	
	59°FDB		64°FDB		68°FDB		73°FDB		77°FDB		81°FDB				
	(°CDB)	(°FDB)	RH	TC	PI	TC	PI	TC	PI	TC	PI	TC	PI	TC	PI
15.2 (100%)	-20	-4	RH85%	10.7	4.62	10.2	4.95	9.81	5.16	9.30	5.24	8.99	5.24	8.69	5.24
	-15	5		12.4	5.20	11.9	5.39	11.5	5.39	11.0	5.39	10.7	5.39	10.4	5.39
	-10	14		13.9	5.48	13.3	5.48	13.0	5.48	12.5	5.48	12.1	5.48	11.8	5.11
	-5	23		15.5	5.56	14.9	5.56	14.6	5.56	14.0	5.56	13.3	5.11	11.9	4.54
	0	32		17.1	5.62	16.5	5.62	16.2	5.62	14.6	5.04	13.3	4.52	11.9	4.02
	5	41		18.4	5.62	17.9	5.62	16.6	5.16	14.6	4.45	13.3	3.99	11.9	3.57
	7	45		19.0	5.62	17.9	5.35	16.6	4.88	14.6	4.21	13.3	3.80	11.9	3.40
	10	50		19.0	5.14	17.9	4.98	16.6	4.55	14.6	3.92	13.3	3.56	11.9	3.21
	15	59		19.9	4.98	17.9	4.38	16.6	4.00	14.6	3.49	13.3	3.18	11.9	2.87
13.7 (90%)	-20	-4	RH85%	10.4	4.84	9.87	5.16	9.53	5.24	9.06	5.24	8.77	5.24	8.49	5.24
	-15	5		12.0	5.39	11.5	5.39	11.2	5.39	10.7	5.39	10.4	5.39	10.1	5.03
	-10	14		13.5	5.48	12.9	5.48	12.6	5.48	12.1	5.48	11.8	5.13	10.8	4.56
	-5	23		15.0	5.56	14.5	5.56	14.1	5.56	13.1	5.08	12.0	4.56	10.8	4.06
	0	32		16.6	5.62	16.0	5.62	14.9	5.16	13.1	4.46	12.0	4.03	10.8	3.62
	5	41		17.9	5.62	16.1	4.98	14.9	4.56	13.1	3.96	12.0	3.59	10.8	3.23
	7	45		17.9	5.35	16.1	4.72	14.9	4.32	13.1	3.75	12.0	3.42	10.8	3.08
	10	50		17.9	4.98	16.1	4.40	14.9	4.03	13.1	3.52	12.0	3.19	10.8	2.89
	15	59		17.9	4.37	16.1	3.89	14.9	3.57	13.1	3.14	12.0	2.86	10.8	2.60
12.2 (80%)	-20	-4	RH85%	10.0	5.10	9.54	5.24	9.23	5.24	8.79	5.24	8.52	5.24	8.26	4.79
	-15	5		11.6	5.39	11.1	5.39	10.8	5.39	10.4	5.39	10.1	4.99	9.56	4.53
	-10	14		13.0	5.48	12.5	5.48	12.2	5.48	11.7	5.01	10.6	4.53	9.56	4.04
	-5	23		14.5	5.56	14.0	5.54	13.3	5.12	11.7	4.45	10.6	4.02	9.56	3.61
	0	32		15.9	5.59	14.3	4.94	13.3	4.50	11.7	3.94	10.6	3.58	9.56	3.23
	5	41		15.9	4.90	14.3	4.35	13.3	4.00	11.7	3.50	10.6	3.19	9.56	2.89
	7	45		15.9	4.64	14.3	4.12	13.3	3.80	11.7	3.33	10.6	3.04	9.56	2.76
	10	50		15.9	4.33	14.3	3.84	13.3	3.55	11.7	3.13	10.6	2.85	9.56	2.60
	15	59		15.9	3.82	14.3	3.43	13.3	3.18	11.7	2.80	10.6	2.57	9.56	2.34
10.6 (70%)	-20	-4	RH85%	9.60	5.24	9.16	5.24	8.88	5.24	8.48	5.07	8.23	4.67	7.99	4.30
	-15	5		11.1	5.39	10.7	5.39	10.4	5.37	10.0	4.82	9.31	4.40	8.37	3.94
	-10	14		12.4	5.48	12.0	5.34	11.6	4.99	10.2	4.34	9.31	3.94	8.37	3.55
	-5	23		13.9	5.42	12.5	4.82	11.6	4.42	10.2	3.86	9.31	3.51	8.37	3.17
	0	32		13.9	4.78	12.5	4.25	11.6	3.92	10.2	3.44	9.31	3.15	8.37	2.84
	5	41		13.9	4.22	12.5	3.76	11.6	3.49	10.2	3.08	9.31	2.83	8.37	2.57
	7	45		13.9	4.01	12.5	3.58	11.6	3.31	10.2	2.94	9.31	2.69	8.37	2.46
	10	50		13.9	3.74	12.5	3.35	11.6	3.11	10.2	2.77	9.31	2.54	8.37	2.32
	15	59		13.9	3.33	12.5	3.00	11.6	2.79	10.2	2.49	9.31	2.29	8.37	2.10
9.1 (60%)	-20	-4	RH85%	9.12	5.24	8.72	5.24	8.47	4.97	8.12	4.46	7.89	4.15	7.17	3.74
	-15	5		10.6	5.39	10.2	5.04	9.96	4.72	8.76	4.14	7.97	3.78	7.17	3.40
	-10	14		11.8	5.11	10.8	4.58	9.96	4.22	8.76	3.72	7.97	3.38	7.17	3.06
	-5	23		12.0	4.55	10.8	4.07	9.96	3.76	8.76	3.32	7.97	3.03	7.17	2.76
	0	32		12.0	4.03	10.8	3.63	9.96	3.36	8.76	2.97	7.97	2.73	7.17	2.50
	5	41		12.0	3.58	10.8	3.24	9.96	3.01	8.76	2.68	7.97	2.46	7.17	2.26
	7	45		12.0	3.42	10.8	3.08	9.96	2.87	8.76	2.56	7.97	2.35	7.17	2.16
	10	50		12.0	3.20	10.8	2.89	9.96	2.70	8.76	2.41	7.97	2.23	7.17	2.04
	15	59		12.0	2.86	10.8	2.60	9.96	2.43	8.76	2.18	7.97	2.03	7.17	1.87
7.6 (50%)	-20	-4	RH85%	8.56	4.97	8.22	4.54	8.00	4.27	7.31	3.81	6.64	3.49	5.98	3.16
	-15	5		9.96	4.73	8.97	4.24	8.30	3.93	7.31	3.46	6.64	3.18	5.98	2.89
	-10	14		9.96	4.23	8.97	3.80	8.30	3.52	7.31	3.13	6.64	2.87	5.98	2.61
	-5	23		9.96	3.76	8.97	3.38	8.30	3.15	7.31	2.81	6.64	2.59	5.98	2.37
	0	32		9.96	3.35	8.97	3.03	8.30	2.83	7.31	2.54	6.64	2.33	5.98	2.15
	5	41		9.96	3.01	8.97	2.73	8.30	2.55	7.31	2.29	6.64	2.12	5.98	1.96
	7	45		9.96	2.87	8.97	2.61	8.30	2.43	7.31	2.20	6.64	2.04	5.98	1.89
	10	50		9.96	2.69	8.97	2.46	8.30	2.30	7.31	2.08	6.64	1.94	5.98	1.79
	15	59		9.96	2.43	8.97	2.23	8.30	2.10	7.31	1.89	6.64	1.77	5.98	1.64

TC : Total Capacity kW

PI : Power Input kW (Comp. + Outdoor fan motor)

The data is based on the following conditions. Pipe length : 7.5m ; Height difference : 0 m.

HEATING CAPACITY 25A

■ HEATING CAPACITY

• MODELS : AJ*A54L, AO*54U

Total Capacity of Indoor Unit (kW)	Outdoor Temperature			Indoor Temperature											
				15°CDB		18°CDB		20°CDB		23°CDB		25°CDB		27°CDB	
	°CDB)	°FDB)	RH	59°FDB		64°FDB		68°FDB		73°FDB		77°FDB		81°FDB	
				TC	PI	TC	PI	TC	PI	TC	PI	TC	PI	TC	PI
22.8 (150%)	-20	-4	RH85%	11.7	3.89	11.0	4.25	10.5	4.48	9.88	4.80	9.49	5.02	9.12	5.02
	-15	5		13.4	4.45	12.8	4.78	12.3	4.98	11.7	5.17	11.3	5.17	10.9	5.17
	-10	14		15.1	4.89	14.4	5.18	13.9	5.24	13.3	5.24	12.9	5.24	12.5	5.24
	-5	23		16.8	5.23	16.1	5.32	15.7	5.32	15.0	5.32	14.6	5.32	14.2	5.32
	0	32		17.9	5.24	17.5	5.28	17.2	5.31	16.7	5.36	16.4	5.38	15.9	5.38
	5	41		18.8	5.14	18.4	5.19	18.1	5.22	17.6	5.26	17.4	5.29	17.1	5.32
	7	45		19.2	5.10	18.8	5.15	18.5	5.18	18.0	5.22	17.8	5.25	17.4	5.26
	15	59		19.4	4.85	19.0	4.90	18.7	4.92	18.3	4.97	18.0	5.00	17.4	4.87
			20.3	4.77	19.9	4.81	19.6	4.84	19.2	4.88	18.6	4.76	17.4	4.29	
21.3 (140%)	-20	-4	RH85%	11.5	4.00	10.8	4.35	10.4	4.57	9.74	4.89	9.36	5.02	9.00	5.02
	-15	5		13.3	4.57	12.6	4.88	12.2	5.08	11.5	5.17	11.2	5.17	10.8	5.17
	-10	14		14.8	5.00	14.1	5.24	13.7	5.24	13.1	5.24	12.7	5.24	12.3	5.24
	-5	23		16.5	5.30	15.9	5.32	15.4	5.32	14.8	5.32	14.4	5.32	14.0	5.32
	0	32		17.8	5.27	17.4	5.31	17.0	5.34	16.5	5.38	16.1	5.38	15.7	5.38
	5	41		18.8	5.19	18.4	5.23	18.0	5.25	17.6	5.29	17.2	5.32	16.7	5.22
	7	45		19.3	5.15	18.8	5.19	18.5	5.22	18.0	5.26	17.7	5.28	16.7	4.93
	10	50		19.5	4.90	19.0	4.94	18.7	4.96	18.2	5.00	17.9	5.03	16.7	4.56
			20.6	4.82	20.1	4.86	19.7	4.89	19.2	4.92	18.0	4.47	16.7	4.04	
19.8 (130%)	-20	-4	RH85%	11.3	4.11	10.6	4.46	10.2	4.68	9.59	5.00	9.22	5.02	8.88	5.02
	-15	5		13.0	4.68	12.4	4.99	11.9	5.17	11.4	5.17	11.0	5.17	10.6	5.17
	-10	14		14.5	5.12	13.9	5.24	13.5	5.24	12.9	5.24	12.5	5.24	12.1	5.24
	-5	23		16.2	5.32	15.6	5.32	15.2	5.32	14.5	5.32	14.2	5.32	13.8	5.32
	0	32		17.7	5.31	17.2	5.34	16.8	5.36	16.3	5.38	15.9	5.38	15.5	5.38
	5	41		18.8	5.24	18.3	5.27	17.9	5.29	17.4	5.32	17.1	5.35	15.5	4.77
	7	45		19.3	5.21	18.7	5.24	18.4	5.26	17.9	5.29	17.1	5.07	15.5	4.53
	10	50		19.6	4.96	19.0	4.99	18.7	5.01	18.1	5.04	17.1	4.74	15.5	4.20
			20.7	4.89	20.1	4.92	19.8	4.94	18.5	4.59	17.1	4.16	15.5	3.74	
18.2 (120%)	-20	-4	RH85%	11.0	4.25	10.4	4.58	9.98	4.80	9.42	5.02	9.07	5.02	8.74	5.02
	-15	5		12.7	4.82	12.1	5.12	11.7	5.17	11.2	5.17	10.8	5.17	10.5	5.17
	-10	14		14.2	5.24	13.6	5.24	13.2	5.24	12.6	5.24	12.3	5.24	11.9	5.24
	-5	23		15.9	5.32	15.3	5.32	14.9	5.32	14.3	5.32	13.9	5.32	13.5	5.32
	0	32		17.5	5.34	16.9	5.36	16.5	5.38	15.9	5.38	15.6	5.38	14.3	4.95
	5	41		18.6	5.29	18.1	5.31	17.7	5.33	17.2	5.35	15.9	4.90	14.3	4.35
	7	45		19.2	5.27	18.6	5.29	18.2	5.31	17.4	5.17	15.9	4.65	14.3	4.13
	10	50		19.5	5.02	18.9	5.04	18.5	5.06	17.4	4.82	15.9	4.33	14.3	3.85
			20.7	4.97	20.1	4.99	19.4	4.85	17.4	4.24	15.9	3.84	14.3	3.42	
16.7 (110%)	-20	-4	RH85%	10.8	4.40	10.2	4.73	9.77	4.94	9.23	5.02	8.90	5.02	8.58	5.02
	-15	5		12.4	4.97	11.8	5.17	11.5	5.17	10.9	5.17	10.6	5.17	10.3	5.17
	-10	14		13.9	5.24	13.3	5.24	12.9	5.24	12.4	5.24	12.0	5.24	11.7	5.24
	-5	23		15.5	5.32	14.9	5.32	14.5	5.32	14.0	5.32	13.6	5.32	13.1	5.05
	0	32		17.1	5.36	16.6	5.38	16.2	5.38	15.6	5.38	14.6	5.04	13.1	4.47
	5	41		18.4	5.34	17.8	5.35	17.4	5.36	16.1	4.98	14.6	4.44	13.1	3.96
	7	45		18.9	5.33	18.3	5.34	17.9	5.35	16.1	4.69	14.6	4.20	13.1	3.76
	10	50		19.3	5.08	18.6	5.09	18.2	5.06	16.1	4.36	14.6	3.94	13.1	3.52
			20.6	5.05	19.5	4.86	18.2	4.46	16.1	3.87	14.6	3.49	13.1	3.14	

TC : Total Capacity kW

PI : Power Input kW (Comp. + Outdoor fan motor)

The data is based on the following conditions. Pipe length : 7.5m ; Height difference : 0 m.

OUTDOOR
UNITS

OUTDOOR
UNITS

HEATING CAPACITY 25A

■ HEATING CAPACITY

• MODELS : AJ*A54L, AO*54U

OUTDOOR UNITS

OUTDOOR UNITS

Total Capacity of Indoor Unit (kW)	Outdoor Temperature			Indoor Temperature											
				15°CDB 59°FDB		18°CDB 64°FDB		20°CDB 68°FDB		23°CDB 73°FDB		25°CDB 77°FDB		27°CDB 81°FDB	
	(°CDB)	(°FDB)	RH	TC	PI	TC	PI	TC	PI	TC	PI	TC	PI	TC	PI
15.2 (100%)	-20	-4	RH85%	10.5	4.58	9.89	4.90	9.53	5.02	9.02	5.02	8.71	5.02	8.41	5.02
	-15	5		12.1	5.15	11.5	5.17	11.2	5.17	10.7	5.17	10.4	5.17	10.1	5.17
	-10	14		13.5	5.24	13.0	5.24	12.6	5.24	12.1	5.24	11.8	5.24	11.5	5.06
	-5	23		15.1	5.32	14.5	5.32	14.2	5.32	13.7	5.32	13.3	5.11	11.9	4.54
	0	32		16.7	5.38	16.1	5.38	15.8	5.38	14.6	5.04	13.3	4.52	11.9	4.02
	5	41		18.0	5.38	17.4	5.38	16.6	5.16	14.6	4.45	13.3	3.99	11.9	3.57
	7	45		18.6	5.38	17.9	5.35	16.6	4.88	14.6	4.21	13.3	3.80	11.9	3.40
	10	50		18.9	5.14	17.9	4.98	16.6	4.55	14.6	3.92	13.3	3.56	11.9	3.21
13.7 (90%)	-20	-4	RH85%	10.1	4.79	9.60	5.02	9.26	5.02	8.79	5.02	8.50	5.02	8.22	5.02
	-15	5		11.7	5.17	11.2	5.17	10.9	5.17	10.4	5.17	10.1	5.17	9.84	4.98
	-10	14		13.1	5.24	12.6	5.24	12.3	5.24	11.8	5.24	11.5	5.08	10.8	4.56
	-5	23		14.6	5.32	14.1	5.32	13.8	5.32	13.1	5.08	12.0	4.56	10.8	4.06
	0	32		16.2	5.38	15.6	5.38	14.9	5.16	13.1	4.46	12.0	4.03	10.8	3.62
	5	41		17.4	5.38	16.1	4.98	14.9	4.56	13.1	3.96	12.0	3.59	10.8	3.23
	7	45		17.9	5.35	16.1	4.72	14.9	4.32	13.1	3.75	12.0	3.42	10.8	3.08
	10	50		17.9	4.98	16.1	4.40	14.9	4.03	13.1	3.52	12.0	3.19	10.8	2.89
12.2 (80%)	-20	-4	RH85%	9.76	5.02	9.27	5.02	8.96	5.02	8.53	5.02	8.25	5.02	7.99	4.75
	-15	5		11.3	5.17	10.8	5.17	10.5	5.17	10.1	5.17	9.83	4.94	9.56	4.53
	-10	14		12.7	5.24	12.2	5.24	11.9	5.24	11.4	4.97	10.6	4.53	9.56	4.04
	-5	23		14.1	5.32	13.6	5.32	13.3	5.12	11.7	4.45	10.6	4.02	9.56	3.61
	0	32		15.6	5.38	14.3	4.94	13.3	4.50	11.7	3.94	10.6	3.58	9.56	3.23
	5	41		15.9	4.90	14.3	4.35	13.3	4.00	11.7	3.50	10.6	3.19	9.56	2.89
	7	45		15.9	4.64	14.3	4.12	13.3	3.80	11.7	3.33	10.6	3.04	9.56	2.76
	10	50		15.9	4.33	14.3	3.84	13.3	3.55	11.7	3.13	10.6	2.85	9.56	2.60
10.6 (70%)	-20	-4	RH85%	9.35	5.02	8.90	5.02	8.62	5.02	8.23	5.02	7.98	4.63	7.74	4.26
	-15	5		10.9	5.16	10.4	5.17	10.1	5.17	9.75	4.77	9.31	4.40	8.37	3.94
	-10	14		12.1	5.24	11.7	5.24	11.4	4.95	10.2	4.34	9.31	3.94	8.37	3.55
	-5	23		13.5	5.32	12.5	4.82	11.6	4.42	10.2	3.86	9.31	3.51	8.37	3.17
	0	32		13.9	4.78	12.5	4.25	11.6	3.92	10.2	3.44	9.31	3.15	8.37	2.84
	5	41		13.9	4.22	12.5	3.76	11.6	3.49	10.2	3.08	9.31	2.83	8.37	2.57
	7	45		13.9	4.01	12.5	3.58	11.6	3.31	10.2	2.94	9.31	2.69	8.37	2.46
	10	50		13.9	3.74	12.5	3.35	11.6	3.11	10.2	2.77	9.31	2.54	8.37	2.32
9.1 (60%)	-20	-4	RH85%	8.88	5.02	8.48	5.02	8.23	4.93	7.88	4.42	7.65	4.10	7.17	3.74
	-15	5		10.3	5.17	9.94	4.99	9.69	4.67	8.76	4.14	7.97	3.78	7.17	3.40
	-10	14		11.5	5.06	10.8	4.58	9.96	4.22	8.76	3.72	7.97	3.38	7.17	3.06
	-5	23		12.0	4.55	10.8	4.07	9.96	3.76	8.76	3.32	7.97	3.03	7.17	2.76
	0	32		12.0	4.03	10.8	3.63	9.96	3.36	8.76	2.97	7.97	2.73	7.17	2.50
	5	41		12.0	3.58	10.8	3.24	9.96	3.01	8.76	2.68	7.97	2.46	7.17	2.26
	7	45		12.0	3.42	10.8	3.08	9.96	2.87	8.76	2.56	7.97	2.35	7.17	2.16
	10	50		12.0	3.20	10.8	2.89	9.96	2.70	8.76	2.41	7.97	2.23	7.17	2.04
7.6 (50%)	-20	-4	RH85%	8.33	4.92	7.99	4.49	7.77	4.23	7.31	3.81	6.64	3.49	5.98	3.16
	-15	5		9.70	4.68	8.97	4.24	8.30	3.93	7.31	3.46	6.64	3.18	5.98	2.89
	-10	14		9.96	4.23	8.97	3.80	8.30	3.52	7.31	3.13	6.64	2.87	5.98	2.61
	-5	23		9.96	3.76	8.97	3.38	8.30	3.15	7.31	2.81	6.64	2.59	5.98	2.37
	0	32		9.96	3.35	8.97	3.03	8.30	2.83	7.31	2.54	6.64	2.33	5.98	2.15
	5	41		9.96	3.01	8.97	2.73	8.30	2.55	7.31	2.29	6.64	2.12	5.98	1.96
	7	45		9.96	2.87	8.97	2.61	8.30	2.43	7.31	2.20	6.64	2.04	5.98	1.89
	10	50		9.96	2.69	8.97	2.46	8.30	2.30	7.31	2.08	6.64	1.94	5.98	1.79
15	59	9.96	2.43	8.97	2.23	8.30	2.10	7.31	1.89	6.64	1.77	5.98	1.64		

TC : Total Capacity kW

PI : Power Input kW (Comp. + Outdoor fan motor)

The data is based on the following conditions. Pipe length : 7.5m ; Height difference : 0 m.

HEATING CAPACITY 20A

■ HEATING CAPACITY

• MODELS : AJ*A54L, AO*54U

Total Capacity of Indoor Unit (kW)	Outdoor Temperature			Indoor Temperature											
				15°CDB 59°FDB		18°CDB 64°FDB		20°CDB 68°FDB		23°CDB 73°FDB		25°CDB 77°FDB		27°CDB 81°FDB	
	(°CDB)	(°FDB)	RH	TC	PI	TC	PI	TC	PI	TC	PI	TC	PI	TC	PI
22.8 (150%)	-20	-4	RH85%	10.0	3.69	9.27	3.90	8.81	3.90	8.18	3.90	7.80	3.90	7.45	3.90
	-15	5		11.6	4.02	10.8	4.02	10.4	4.02	9.77	4.02	9.39	4.02	9.03	4.02
	-10	14		12.9	4.07	12.2	4.07	11.8	4.07	11.1	4.07	10.7	4.07	10.4	4.07
	-5	23		14.5	4.13	13.8	4.13	13.3	4.13	12.7	4.13	12.3	4.13	11.9	4.13
	0	32		16.2	4.18	15.4	4.18	15.0	4.18	14.3	4.18	13.9	4.18	13.4	4.18
	5	41		17.2	4.12	16.7	4.17	16.3	4.18	15.6	4.18	15.1	4.18	14.7	4.18
	7	45		17.6	4.09	17.1	4.13	16.8	4.16	16.2	4.18	15.7	4.18	15.2	4.18
	10	50		18.1	4.05	17.7	4.09	17.3	4.12	16.8	4.16	16.5	4.18	16.0	4.18
15	59	19.1	3.98	18.6	4.01	18.2	4.04	17.8	4.08	17.4	4.11	17.1	4.13		
21.3 (140%)	-20	-4	RH85%	9.85	3.79	9.12	3.90	8.67	3.90	8.07	3.90	7.70	3.90	7.36	3.90
	-15	5		11.4	4.02	10.7	4.02	10.2	4.02	9.64	4.02	9.27	4.02	8.92	4.02
	-10	14		12.7	4.07	12.0	4.07	11.6	4.07	11.0	4.07	10.6	4.07	10.2	4.07
	-5	23		14.3	4.13	13.6	4.13	13.1	4.13	12.5	4.13	12.1	4.13	11.7	4.13
	0	32		15.9	4.18	15.2	4.18	14.7	4.18	14.1	4.18	13.7	4.18	13.2	4.18
	5	41		17.1	4.15	16.5	4.18	16.0	4.18	15.3	4.18	14.9	4.18	14.5	4.18
	7	45		17.5	4.12	17.0	4.15	16.6	4.18	15.9	4.18	15.4	4.18	15.0	4.18
	10	50		18.1	4.08	17.5	4.11	17.2	4.14	16.7	4.17	16.2	4.18	15.8	4.18
15	59	19.1	4.01	18.6	4.05	18.2	4.07	17.7	4.11	17.3	4.13	16.7	4.04		
19.8 (130%)	-20	-4	RH85%	9.65	3.90	8.95	3.90	8.52	3.90	7.94	3.90	7.59	3.90	7.26	3.90
	-15	5		11.1	4.02	10.5	4.02	10.1	4.02	9.49	4.02	9.14	4.02	8.80	4.02
	-10	14		12.5	4.07	11.8	4.07	11.4	4.07	10.8	4.07	10.4	4.07	10.1	4.07
	-5	23		14.0	4.13	13.3	4.13	12.9	4.13	12.3	4.13	11.9	4.13	11.6	4.13
	0	32		15.6	4.18	14.9	4.18	14.5	4.18	13.8	4.18	13.4	4.18	13.0	4.18
	5	41		16.8	4.17	16.2	4.18	15.7	4.18	15.1	4.18	14.6	4.18	14.2	4.18
	7	45		17.3	4.14	16.7	4.17	16.3	4.18	15.6	4.18	15.2	4.18	14.7	4.18
	10	50		17.9	4.11	17.3	4.14	17.0	4.16	16.4	4.18	15.9	4.18	15.5	4.18
15	59	19.0	4.06	18.4	4.08	18.1	4.10	17.5	4.13	17.1	4.15	15.5	3.74		
18.2 (120%)	-20	-4	RH85%	9.43	3.90	8.77	3.90	8.36	3.90	7.81	3.90	7.47	3.90	7.16	3.90
	-15	5		10.9	4.02	10.3	4.02	9.88	4.02	9.33	4.02	8.99	4.02	8.66	4.02
	-10	14		12.2	4.07	11.6	4.07	11.2	4.07	10.6	4.07	10.3	4.07	9.94	4.07
	-5	23		13.7	4.13	13.1	4.13	12.7	4.13	12.1	4.13	11.7	4.13	11.4	4.13
	0	32		15.2	4.18	14.6	4.18	14.2	4.18	13.6	4.18	13.2	4.18	12.8	4.18
	5	41		16.5	4.18	15.8	4.18	15.4	4.18	14.7	4.18	14.3	4.18	13.9	4.18
	7	45		17.0	4.16	16.4	4.18	15.9	4.18	15.3	4.18	14.9	4.18	14.3	4.13
	10	50		17.7	4.14	17.1	4.16	16.7	4.17	16.0	4.18	15.6	4.18	14.3	3.85
15	59	18.9	4.10	18.2	4.12	17.8	4.14	17.2	4.16	16.0	3.84	14.3	3.42		
16.7 (110%)	-20	-4	RH85%	9.19	3.90	8.56	3.90	8.18	3.90	7.66	3.90	7.34	3.90	7.04	3.90
	-15	5		10.6	4.02	10.0	4.02	9.67	4.02	9.15	4.02	8.82	4.02	8.51	4.02
	-10	14		11.9	4.07	11.3	4.07	10.9	4.07	10.4	4.07	10.1	4.07	9.76	4.07
	-5	23		13.4	4.13	12.8	4.13	12.4	4.13	11.8	4.13	11.5	4.13	11.1	4.13
	0	32		14.9	4.18	14.2	4.18	13.8	4.18	13.3	4.18	12.9	4.18	12.5	4.18
	5	41		16.1	4.18	15.4	4.18	15.0	4.18	14.4	4.18	14.0	4.18	13.1	3.96
	7	45		16.6	4.18	16.0	4.18	15.5	4.18	14.9	4.18	14.6	4.18	13.1	3.76
	10	50		17.3	4.16	16.7	4.18	16.3	4.18	15.6	4.18	14.6	3.94	13.1	3.52
15	59	18.6	4.14	17.9	4.15	17.5	4.16	16.1	3.87	14.6	3.49	13.1	3.14		

TC : Total Capacity kW

PI : Power Input kW (Comp. + Outdoor fan motor)

The data is based on the following conditions. Pipe length : 7.5m ; Height difference : 0 m.

OUTDOOR UNITS

OUTDOOR UNITS

HEATING CAPACITY

HEATING CAPACITY 20A

- MODELS : AJ*A54L, AO*54U

Total Capacity of Indoor Unit (kW)	Outdoor Temperature			Indoor Temperature											
				15°CDB		18°CDB		20°CDB		23°CDB		25°CDB		27°CDB	
	(°CDB)	(°FDB)	RH	59°FDB		64°FDB		68°FDB		73°FDB		77°FDB		81°FDB	
			TC	PI	TC	PI	TC	PI	TC	PI	TC	PI	TC	PI	
15.2 (100%)	-20	-4	RH85%	8.93	3.90	8.34	3.90	7.99	3.90	7.49	3.90	7.19	3.90	6.90	3.90
	-15	5		10.4	4.02	9.79	4.02	9.44	4.02	8.95	4.02	8.64	4.02	8.34	4.02
	-10	14		11.6	4.07	11.0	4.07	10.7	4.07	10.2	4.07	9.86	4.07	9.56	4.07
	-5	23		13.0	4.13	12.4	4.13	12.1	4.13	11.6	4.13	11.2	4.13	10.9	4.13
	0	32		14.5	4.18	13.9	4.18	13.5	4.18	12.9	4.18	12.6	4.18	11.9	4.02
	5	41		15.6	4.18	15.0	4.18	14.6	4.18	14.0	4.18	13.3	3.99	11.9	3.57
	7	45		16.1	4.18	15.5	4.18	15.1	4.18	14.6	4.18	13.3	3.80	11.9	3.40
	10	50		16.9	4.18	16.2	4.18	15.8	4.18	14.6	3.92	13.3	3.56	11.9	3.21
15	59	18.1	4.18	17.5	4.18	16.6	4.00	14.6	3.49	13.3	3.18	11.9	2.87		
13.7 (90%)	-20	-4	RH85%	8.64	3.90	8.10	3.90	7.77	3.90	7.30	3.90	7.02	3.90	6.75	3.90
	-15	5		10.0	4.02	9.51	4.02	9.18	4.02	8.72	4.02	8.43	4.02	8.15	4.02
	-10	14		11.2	4.07	10.7	4.07	10.4	4.07	9.91	4.07	9.61	4.07	9.33	4.07
	-5	23		12.6	4.13	12.1	4.13	11.7	4.13	11.2	4.13	10.9	4.13	10.6	4.04
	0	32		14.0	4.18	13.4	4.18	13.1	4.18	12.6	4.18	12.0	4.03	10.8	3.62
	5	41		15.1	4.18	14.5	4.18	14.2	4.18	13.1	3.96	12.0	3.59	10.8	3.23
	7	45		15.6	4.18	15.0	4.18	14.6	4.18	13.1	3.75	12.0	3.42	10.8	3.08
	10	50		16.3	4.18	15.7	4.18	14.9	4.03	13.1	3.52	12.0	3.19	10.8	2.89
15	59	17.5	4.18	16.1	3.89	14.9	3.57	13.1	3.14	12.0	2.86	10.8	2.60		
12.2 (80%)	-20	-4	RH85%	8.32	3.90	7.82	3.90	7.52	3.90	7.09	3.90	6.82	3.90	6.57	3.90
	-15	5		9.68	4.02	9.20	4.02	8.89	4.02	8.46	4.02	8.19	4.02	7.93	4.02
	-10	14		10.8	4.07	10.4	4.07	10.1	4.07	9.61	4.07	9.33	4.07	9.07	3.97
	-5	23		12.1	4.13	11.7	4.13	11.3	4.13	10.9	4.13	10.6	4.01	9.56	3.61
	0	32		13.5	4.18	13.0	4.18	12.6	4.18	11.7	3.94	10.6	3.58	9.56	3.23
	5	41		14.5	4.18	14.0	4.18	13.3	4.00	11.7	3.50	10.6	3.19	9.56	2.89
	7	45		15.0	4.18	14.3	4.12	13.3	3.80	11.7	3.33	10.6	3.04	9.56	2.76
	10	50		15.6	4.18	14.3	3.84	13.3	3.55	11.7	3.13	10.6	2.85	9.56	2.60
15	59	15.9	3.82	14.3	3.43	13.3	3.18	11.7	2.80	10.6	2.57	9.56	2.34		
10.6 (70%)	-20	-4	RH85%	7.96	3.90	7.51	3.90	7.24	3.90	6.85	3.90	6.60	3.90	6.37	3.90
	-15	5		9.27	4.02	8.84	4.02	8.56	4.02	8.17	4.02	7.92	4.02	7.68	3.84
	-10	14		10.4	4.07	9.95	4.07	9.67	4.08	9.27	4.07	9.01	3.90	8.37	3.55
	-5	23		11.6	4.13	11.2	4.13	10.9	4.13	10.2	3.86	9.31	3.51	8.37	3.17
	0	32		12.9	4.18	12.4	4.18	11.6	3.92	10.2	3.44	9.31	3.15	8.37	2.84
	5	41		13.9	4.18	12.5	3.76	11.6	3.49	10.2	3.08	9.31	2.83	8.37	2.57
	7	45		13.9	4.01	12.5	3.58	11.6	3.31	10.2	2.94	9.31	2.69	8.37	2.46
	10	50		13.9	3.74	12.5	3.35	11.6	3.11	10.2	2.77	9.31	2.54	8.37	2.32
15	59	13.9	3.33	12.5	3.00	11.6	2.79	10.2	2.49	9.31	2.29	8.37	2.10		
9.1 (60%)	-20	-4	RH85%	7.56	3.90	7.16	3.90	6.91	3.90	6.56	3.90	6.34	3.89	6.13	3.57
	-15	5		8.81	4.02	8.42	4.02	8.18	4.02	7.82	3.99	7.60	3.71	7.17	3.40
	-10	14		9.87	4.07	9.48	4.07	9.23	4.07	8.76	3.72	7.97	3.38	7.17	3.06
	-5	23		11.0	4.13	10.6	4.05	9.96	3.76	8.76	3.32	7.97	3.03	7.17	2.76
	0	32		12.0	4.03	10.8	3.63	9.96	3.36	8.76	2.97	7.97	2.73	7.17	2.50
	5	41		12.0	3.58	10.8	3.24	9.96	3.01	8.76	2.68	7.97	2.46	7.17	2.26
	7	45		12.0	3.42	10.8	3.08	9.96	2.87	8.76	2.56	7.97	2.35	7.17	2.16
	10	50		12.0	3.20	10.8	2.89	9.96	2.70	8.76	2.41	7.97	2.23	7.17	2.04
15	59	12.0	2.86	10.8	2.60	9.96	2.43	8.76	2.18	7.97	2.03	7.17	1.87		
7.6 (50%)	-20	-4	RH85%	7.09	3.90	6.74	3.90	6.53	3.90	6.22	3.63	6.03	3.39	5.84	3.14
	-15	5		8.28	4.02	7.94	4.02	7.72	3.83	7.31	3.46	6.64	3.18	5.98	2.89
	-10	14		9.27	4.07	8.93	3.79	8.30	3.52	7.31	3.13	6.64	2.87	5.98	2.61
	-5	23		9.96	3.76	8.97	3.38	8.30	3.15	7.31	2.81	6.64	2.59	5.98	2.37
	0	32		9.96	3.35	8.97	3.03	8.30	2.83	7.31	2.54	6.64	2.33	5.98	2.15
	5	41		9.96	3.01	8.97	2.73	8.30	2.55	7.31	2.29	6.64	2.12	5.98	1.96
	7	45		9.96	2.87	8.97	2.61	8.30	2.43	7.31	2.20	6.64	2.04	5.98	1.89
	10	50		9.96	2.69	8.97	2.46	8.30	2.30	7.31	2.08	6.64	1.94	5.98	1.79
15	59	9.96	2.43	8.97	2.23	8.30	2.10	7.31	1.89	6.64	1.77	5.98	1.64		

TC : Total Capacity kW
PI : Power Input kW (Comp. + Outdoor fan motor)

The data is based on the following conditions. Pipe length : 7.5m ; Height difference : 0 m.

HEATING CAPACITY 15A

■ HEATING CAPACITY

• MODELS : AJ*A54L, AO*54U

Total Capacity of Indoor Unit (kW)	Outdoor Temperature (°CDB) (°FDB) RH			Indoor Temperature											
				15°CDB 59°FDB		18°CDB 64°FDB		20°CDB 68°FDB		23°CDB 73°FDB		25°CDB 77°FDB		27°CDB 81°FDB	
				TC	PI	TC	PI	TC	PI	TC	PI	TC	PI	TC	PI
22.8 (150%)	-20	-4	RH85%	7.89	2.79	7.15	2.79	6.71	2.79	6.13	2.79	5.79	2.79	5.48	2.79
	-15	5		9.13	2.87	8.43	2.87	8.00	2.87	7.42	2.87	7.07	2.87	6.74	2.87
	-10	14		10.2	2.91	9.55	2.91	9.12	2.91	8.53	2.91	8.16	2.91	7.82	2.91
	-5	23		11.6	2.95	10.9	2.95	10.4	2.95	9.81	2.95	9.42	2.95	9.06	2.95
	0	32		13.0	2.98	12.3	2.98	11.8	2.98	11.2	2.98	10.7	2.98	10.4	2.98
	5	41		14.2	2.98	13.4	2.98	12.9	2.98	12.3	2.98	11.8	2.98	11.4	2.98
	7	45		14.8	2.98	14.0	2.98	13.5	2.98	12.8	2.98	12.3	2.98	11.9	2.98
	10	50		15.5	2.98	14.7	2.98	14.2	2.98	13.5	2.98	13.0	2.98	12.5	2.98
15	59	16.8	2.96	16.1	2.98	15.5	2.98	14.7	2.98	14.2	2.98	13.7	2.98		
21.3 (140%)	-20	-4	RH85%	7.75	2.79	7.03	2.79	6.61	2.79	6.05	2.79	5.72	2.79	5.42	2.79
	-15	5		8.98	2.87	8.30	2.87	7.88	2.87	7.32	2.87	6.98	2.87	6.67	2.87
	-10	14		10.1	2.91	9.40	2.91	8.99	2.91	8.41	2.91	8.06	2.91	7.73	2.91
	-5	23		11.4	2.95	10.7	2.95	10.3	2.95	9.67	2.95	9.30	2.95	8.95	2.95
	0	32		12.8	2.98	12.1	2.98	11.6	2.98	11.0	2.98	10.6	2.98	10.2	2.98
	5	41		13.9	2.98	13.2	2.98	12.7	2.98	12.1	2.98	11.6	2.98	11.2	2.98
	7	45		14.5	2.98	13.7	2.98	13.2	2.98	12.6	2.98	12.1	2.98	11.7	2.98
	10	50		15.2	2.98	14.4	2.98	13.9	2.98	13.2	2.98	12.8	2.98	12.3	2.98
15	59	16.6	2.98	15.8	2.98	15.2	2.98	14.5	2.98	14.0	2.98	13.5	2.98		
19.8 (130%)	-20	-4	RH85%	7.59	2.79	6.91	2.79	6.51	2.79	5.97	2.79	5.65	2.79	5.36	2.79
	-15	5		8.80	2.87	8.15	2.87	7.76	2.87	7.22	2.87	6.89	2.87	6.59	2.87
	-10	14		9.88	2.91	9.24	2.91	8.84	2.91	8.29	2.91	7.95	2.91	7.63	2.91
	-5	23		11.2	2.95	10.5	2.95	10.1	2.95	9.52	2.95	9.16	2.95	8.82	2.95
	0	32		12.5	2.98	11.8	2.98	11.4	2.98	10.8	2.98	10.4	2.98	10.1	2.98
	5	41		13.7	2.98	12.9	2.98	12.5	2.98	11.9	2.98	11.4	2.98	11.0	2.98
	7	45		14.2	2.98	13.5	2.98	13.0	2.98	12.3	2.98	11.9	2.98	11.5	2.98
	10	50		14.9	2.98	14.2	2.98	13.7	2.98	13.0	2.98	12.5	2.98	12.1	2.98
15	59	16.2	2.98	15.4	2.98	14.9	2.98	14.2	2.98	13.7	2.98	13.2	2.98		
18.2 (120%)	-20	-4	RH85%	7.42	2.79	6.77	2.79	6.39	2.79	5.88	2.79	5.57	2.79	5.29	2.79
	-15	5		8.62	2.87	8.00	2.87	7.62	2.87	7.10	2.87	6.79	2.87	6.49	2.87
	-10	14		9.67	2.91	9.06	2.91	8.68	2.91	8.15	2.91	7.83	2.91	7.52	2.91
	-5	23		10.9	2.95	10.3	2.95	9.91	2.95	9.36	2.95	9.01	2.95	8.69	2.95
	0	32		12.3	2.98	11.6	2.98	11.2	2.98	10.6	2.98	10.2	2.98	9.89	2.98
	5	41		13.3	2.98	12.7	2.98	12.2	2.98	11.6	2.98	11.2	2.98	10.8	2.98
	7	45		13.9	2.98	13.2	2.98	12.7	2.98	12.1	2.98	11.7	2.98	11.3	2.98
	10	50		14.5	2.98	13.8	2.98	13.4	2.98	12.7	2.98	12.3	2.98	11.9	2.98
15	59	15.8	2.98	15.1	2.98	14.6	2.98	13.9	2.98	13.4	2.98	13.0	2.98		
16.7 (110%)	-20	-4	RH85%	7.23	2.79	6.62	2.79	6.26	2.79	5.77	2.79	5.48	2.79	5.21	2.79
	-15	5		8.41	2.87	7.83	2.87	7.47	2.87	6.98	2.87	6.67	2.87	6.39	2.87
	-10	14		9.45	2.91	8.87	2.91	8.51	2.91	8.00	2.91	7.69	2.91	7.39	2.91
	-5	23		10.7	2.95	10.1	2.95	9.70	2.95	9.18	2.95	8.85	2.95	8.53	2.95
	0	32		12.0	2.98	11.3	2.98	10.9	2.98	10.4	2.98	10.0	2.98	9.70	2.98
	5	41		13.0	2.98	12.4	2.98	12.0	2.98	11.4	2.98	11.0	2.98	10.6	2.98
	7	45		13.5	2.98	12.8	2.98	12.4	2.98	11.8	2.98	11.4	2.98	11.0	2.98
	10	50		14.2	2.98	13.5	2.98	13.0	2.98	12.4	2.98	12.0	2.98	11.6	2.98
15	59	15.4	2.98	14.6	2.98	14.2	2.98	13.5	2.98	13.1	2.98	12.6	2.98		

TC : Total Capacity kW

PI : Power Input kW (Comp. + Outdoor fan motor)

The data is based on the following conditions. Pipe length : 7.5m ; Height difference : 0 m.

HEATING CAPACITY

HEATING CAPACITY 15A

• MODELS : AJ*A54L, AO*54U

Total Capacity of Indoor Unit (kW)	Outdoor Temperature (°CDB) (°FDB) RH			Indoor Temperature											
				15°CDB		18°CDB		20°CDB		23°CDB		25°CDB		27°CDB	
				59°FDB		64°FDB		68°FDB		73°FDB		77°FDB		81°FDB	
			TC	PI	TC	PI	TC	PI	TC	PI	TC	PI	TC	PI	
15.2 (100%)	-20	-4	RH85%	7.03	2.79	6.46	2.79	6.12	2.79	5.66	2.79	5.38	2.79	5.12	2.79
	-15	5		8.19	2.87	7.64	2.87	7.30	2.87	6.83	2.87	6.54	2.87	6.28	2.87
	-10	14		9.20	2.91	8.65	2.91	8.31	2.91	7.83	2.91	7.54	2.91	7.25	2.91
	-5	23		10.4	2.95	9.82	2.95	9.47	2.95	8.97	2.95	8.66	2.95	8.36	2.95
	0	32		11.6	2.98	11.0	2.98	10.7	2.98	10.1	2.98	9.81	2.98	9.49	2.98
	5	41		12.6	2.98	12.0	2.98	11.6	2.98	11.1	2.98	10.7	2.98	10.4	2.98
	7	45		13.1	2.98	12.5	2.98	12.1	2.98	11.5	2.98	11.1	2.98	10.8	2.98
	10	50		13.7	2.98	13.1	2.98	12.7	2.98	12.1	2.98	11.7	2.98	11.3	2.98
15	59	14.9	2.98	14.2	2.98	13.7	2.98	13.1	2.98	12.7	2.98	12.0	2.87		
13.7 (90%)	-20	-4	RH85%	6.80	2.79	6.28	2.79	5.96	2.79	5.52	2.79	5.26	2.79	5.02	2.79
	-15	5		7.94	2.87	7.42	2.87	7.11	2.87	6.67	2.87	6.40	2.87	6.14	2.87
	-10	14		8.92	2.91	8.41	2.91	8.09	2.91	7.64	2.91	7.36	2.91	7.09	2.91
	-5	23		10.1	2.95	9.54	2.95	9.21	2.95	8.74	2.95	8.44	2.95	8.16	2.95
	0	32		11.3	2.98	10.7	2.98	10.4	2.98	9.87	2.98	9.56	2.98	9.25	2.98
	5	41		12.2	2.98	11.6	2.98	11.3	2.98	10.8	2.98	10.4	2.98	10.1	2.98
	7	45		12.7	2.98	12.1	2.98	11.7	2.98	11.2	2.98	10.8	2.98	10.5	2.98
	10	50		13.2	2.98	12.6	2.98	12.3	2.98	11.7	2.98	11.3	2.98	10.8	2.89
15	59	14.3	2.98	13.7	2.98	13.3	2.98	12.7	2.98	11.9	2.86	10.8	2.60		
12.2 (80%)	-20	-4	RH85%	6.56	2.79	6.07	2.79	5.78	2.79	5.37	2.79	5.13	2.79	4.90	2.79
	-15	5		7.66	2.87	7.18	2.87	6.89	2.87	6.48	2.87	6.23	2.87	5.99	2.87
	-10	14		8.61	2.91	8.14	2.91	7.84	2.91	7.42	2.91	7.16	2.91	6.91	2.91
	-5	23		9.70	2.95	9.22	2.95	8.91	2.95	8.48	2.95	8.20	2.95	7.94	2.95
	0	32		10.8	2.98	10.3	2.98	10.0	2.98	9.56	2.98	9.26	2.98	8.98	2.98
	5	41		11.7	2.98	11.2	2.98	10.9	2.98	10.4	2.98	10.1	2.98	9.56	2.89
	7	45		12.2	2.98	11.6	2.98	11.3	2.98	10.8	2.98	10.4	2.98	9.56	2.76
	10	50		12.7	2.98	12.2	2.98	11.8	2.98	11.3	2.98	10.6	2.85	9.56	2.60
15	59	13.7	2.98	13.1	2.98	12.7	2.98	11.7	2.80	10.6	2.57	9.56	2.34		
10.6 (70%)	-20	-4	RH85%	6.28	2.79	5.84	2.79	5.57	2.79	5.20	2.79	4.97	2.79	4.76	2.79
	-15	5		7.34	2.87	6.91	2.87	6.64	2.87	6.27	2.87	6.04	2.87	5.82	2.87
	-10	14		8.26	2.91	7.83	2.91	7.55	2.91	7.17	2.91	6.93	2.91	6.70	2.91
	-5	23		9.30	2.95	8.86	2.95	8.58	2.95	8.17	2.95	7.92	2.95	7.67	2.95
	0	32		10.4	2.98	9.91	2.98	9.62	2.98	9.19	2.98	8.92	2.98	8.37	2.84
	5	41		11.2	2.98	10.7	2.98	10.4	2.98	9.98	2.98	9.31	2.83	8.37	2.57
	7	45		11.6	2.98	11.1	2.98	10.8	2.98	10.2	2.94	9.31	2.69	8.37	2.46
	10	50		12.1	2.98	11.6	2.98	11.3	2.98	10.2	2.77	9.31	2.54	8.37	2.32
15	59	13.0	2.98	12.5	2.98	11.6	2.79	10.2	2.49	9.31	2.29	8.37	2.10		
9.1 (60%)	-20	-4	RH85%	5.96	2.79	5.57	2.79	5.33	2.79	5.00	2.79	4.79	2.79	4.60	2.79
	-15	5		6.98	2.87	6.60	2.87	6.36	2.87	6.02	2.87	5.81	2.87	5.61	2.87
	-10	14		7.85	2.91	7.46	2.91	7.22	2.91	6.87	2.91	6.65	2.91	6.44	2.91
	-5	23		8.83	2.95	8.44	2.95	8.18	2.95	7.82	2.95	7.59	2.95	7.17	2.76
	0	32		9.83	2.98	9.42	2.98	9.15	2.98	8.76	2.97	7.97	2.73	7.17	2.50
	5	41		10.6	2.98	10.2	2.98	9.90	2.98	8.76	2.68	7.97	2.46	7.17	2.26
	7	45		11.0	2.98	10.5	2.98	9.96	2.87	8.76	2.56	7.97	2.35	7.17	2.16
	10	50		11.4	2.98	10.8	2.89	9.96	2.70	8.76	2.41	7.97	2.23	7.17	2.04
15	59	12.0	2.86	10.8	2.60	9.96	2.43	8.76	2.18	7.97	2.03	7.17	1.87		
7.6 (50%)	-20	-4	RH85%	5.59	2.79	5.26	2.79	5.05	2.79	4.75	2.79	4.57	2.79	4.40	2.79
	-15	5		6.56	2.87	6.23	2.87	6.02	2.87	5.72	2.87	5.53	2.87	5.35	2.80
	-10	14		7.38	2.91	7.04	2.91	6.82	2.91	6.52	2.91	6.32	2.83	5.98	2.61
	-5	23		8.29	2.95	7.94	2.95	7.72	2.95	7.31	2.81	6.64	2.59	5.98	2.37
	0	32		9.20	2.98	8.84	2.98	8.30	2.83	7.31	2.54	6.64	2.33	5.98	2.15
	5	41		9.90	2.98	8.97	2.73	8.30	2.55	7.31	2.29	6.64	2.12	5.98	1.96
	7	45		9.96	2.87	8.97	2.61	8.30	2.43	7.31	2.20	6.64	2.04	5.98	1.89
	10	50		9.96	2.69	8.97	2.46	8.30	2.30	7.31	2.08	6.64	1.94	5.98	1.79
15	59	9.96	2.43	8.97	2.23	8.30	2.10	7.31	1.89	6.64	1.77	5.98	1.64		

TC : Total Capacity kW

PI : Power Input kW (Comp. + Outdoor fan motor)

The data is based on the following conditions. Pipe length : 7.5m ; Height difference : 0 m.

3-8. SELECTION PROCEDURE BASED ON A DESIGN

3-8-1. SELECTION PROCEDURE OF INDOOR UNIT AND OUTDOOR UNIT

The following conditions must be satisfied.

- 1) Maximum number of connectable indoor units is 8.
- 2) The total rated cooling capacity of indoor units must be within range of 7.6 to 22.8 kW.

※ Please select indoor unit whose capacity is larger than cooling and heating load.

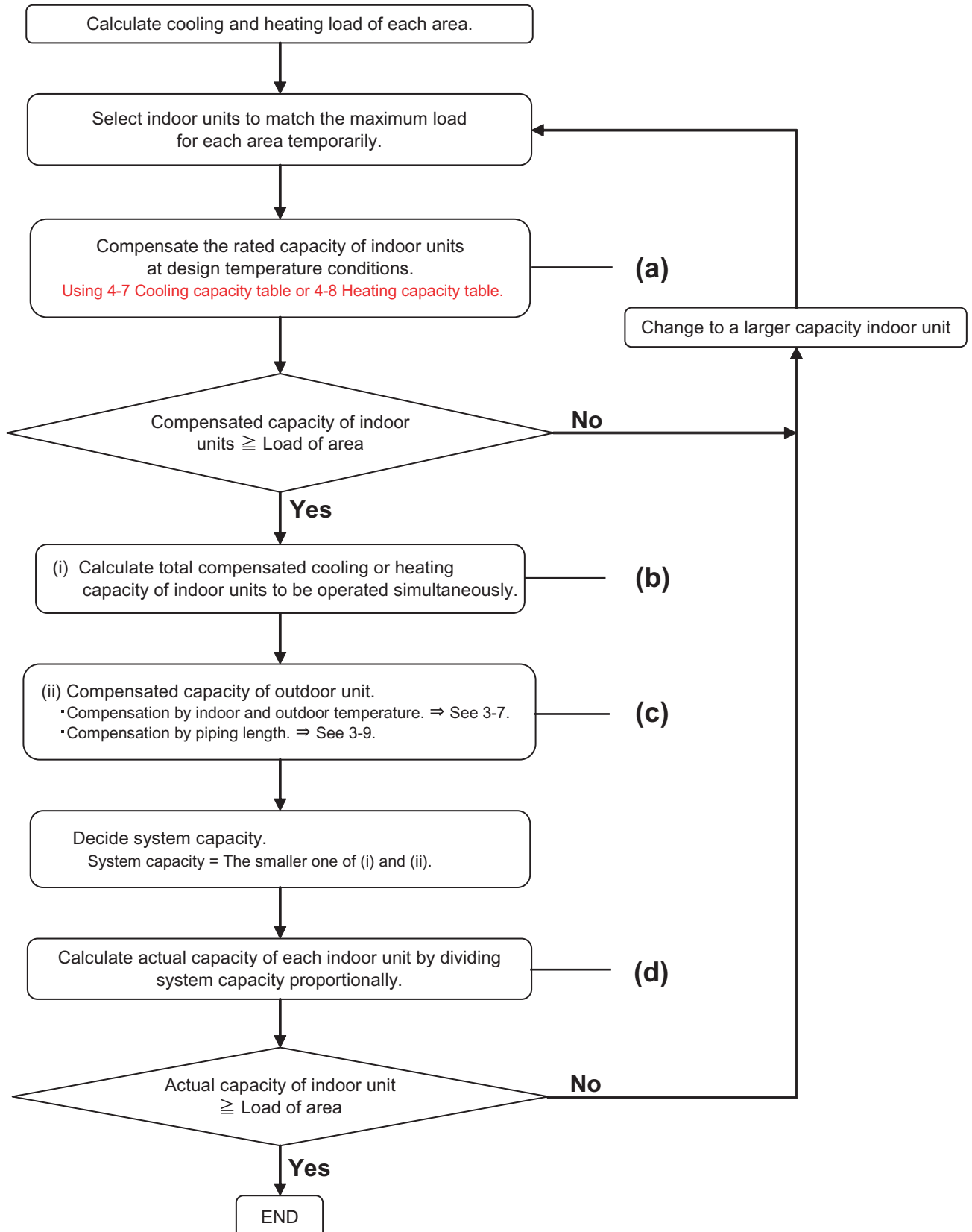

3-8-2. METHOD OF CAPACITY CALCULATION

The calculation method for actual capacity of indoor unit in consideration of indoor and outdoor temperature, piping length is shown below.

1. Calculate total compensated cooling and heating capacity of indoor units.

Check the data of TC using Capacity Tables at design temperature conditions.

⇒ See 4-8 or 4-9. ①

Compensated capacity of each indoor unit = TC.

Total compensated capacity of indoor units = Sum of TC of the indoor units to be operated simultaneously.

} (a)
} (b)

2. Calculate the compensated capacity of outdoor unit.

Compensated capacity of outdoor unit =

Capacity of outdoor unit at design temperature conditions ②

x Coefficient of pipe length compensation ③

② Value of TC from capacity table (Outdoor Unit) ⇒ See 3-7.

③ Coefficient from refrigerant pipe length compensation ⇒ See 3-9.

} (c)

3. Decide system capacity

System capacity = The smaller one of { **Total compensated capacity of indoor units.**
and
Compensated capacity of outdoor unit.

4. Calculate of actual capacity of indoor unit

Actual capacity of indoor unit

= (System capacity) x $\frac{\text{Rated capacity of indoor unit}}{\text{Total rate capacity of indoor units to be operated simultaneously}}$ (d)

OUTDOOR
UNITS

OUTDOOR
UNITS

3-8-3 THE EXAMPLE OF CALCULATION

● System outline

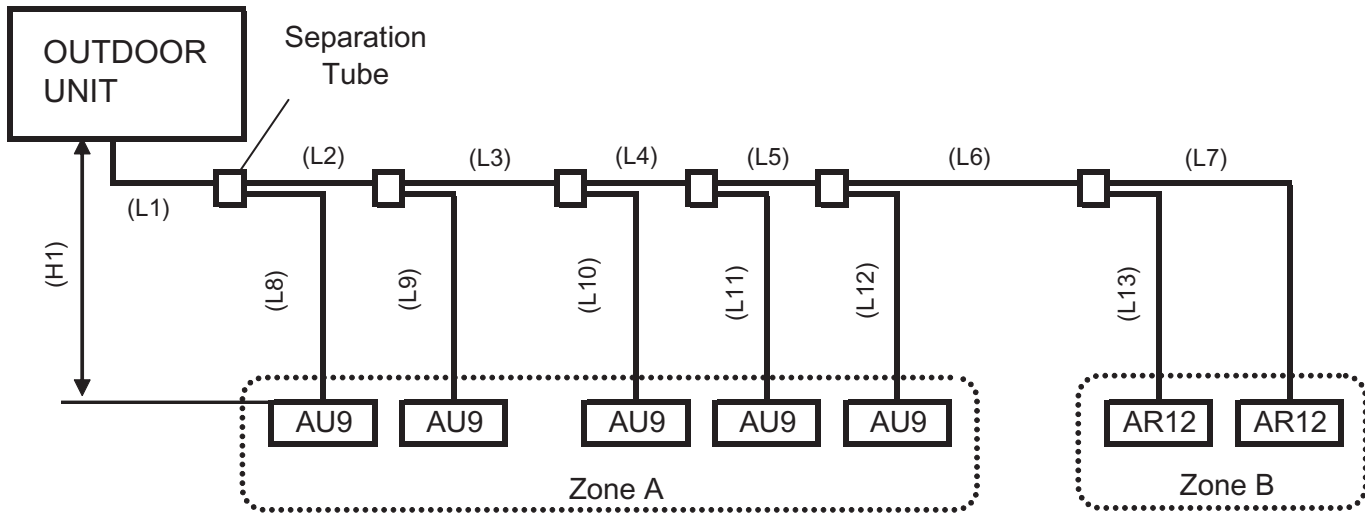

i) Rated capacity and number of the units

	Model name	Rate capacity (kW)	Number of the units
Outdoor unit	-	15.2	1
Indoor unit	AU9	2.80	5
Indoor unit	AR12	3.50	2

ii) Air conditioning area and total capacity of the indoor units

Area	Indoor units	Total rated capacity (kW) (ratio to outdoor unit)
Zone A	AU9 x 5	14.0 (92.1%)
Zone B	AR12 x 2	7.00 (46.1%)
Zone A&B	AU9 x 5 + AR12 x 2	21.0 (138.2%)

iii) Installation conditions

Breaker capacity	30 (A)
Pipe length	(L1) = 32 (m) (L2) = (L3) = (L4) = (L5) = (L6) = (L7) = (L8) = (L9) = (L10) = (L11) = (L12) = (L13) = 3.0m

● Design temperature conditions

Indoor temperature	28 °CDB
Outdoor temperature	40 °CDB

● Compensated capacity of indoor units

i) Refer to 4-7. COOLING CAPACITY TABLE to find the compensated capacity at design temperature conditions.

ii) Select indoor unit whose compensated capacity is larger than the load of room.

	Cooling compensated capacity TC (kW)
AU9	2.72
AR12	3.40

● Calculation for actual capacity

(1-1) All indoor units (Capacity ratio : 138.2%) operate simultaneously.

1. Total compensated capacity of indoor units	2.72 x 5 + 3.40 x 2 = 20.4 kW		
2. Compensated capacity of outdoor unit			
Capacity of outdoor unit	16.56 kW ^{*1)}		See below
Coefficient of compensation for piping length	0.950	Pipe length = L1 + L2 + L3 + L4 + L5 + L6 + L7 = 50 (m)	See 3-9
Capacity of outdoor unit after compensation	16.56 X 0.95 = 15.7 kW		
3. Decide system capacity	15.7 kW (15.7 / 20.4 = 77.0%)		See 3-8-2
4. Actual capacity of indoor unit	AU9	15.7 x 2.72 / 20.4 = 2.09 kW	See 3-8-2
	AR12	15.7 x 3.40 / 20.4 = 2.62 kW	

(1-2) The indoor units in zone A (Capacity ratio : 92.1%) are operating while the others are stopped.

1. Total compensated capacity of indoor units	2.72 x 5 = 13.6 kW		
2. Compensated capacity of outdoor unit			
Capacity of outdoor unit	13.83 kW ^{*1)}		See below
Coefficient of compensation for piping length	0.953	Pipe length = L1 + L2 + L3 + L4 + L5 + L12 = 47 (m)	See 3-9
Capacity of outdoor unit after compensation	13.83 x 0.953 = 13.2 kW		
3. Decide system capacity	13.2 kW (13.2 / 13.6 = 97.1%)		See 3-8-2
4. Actual capacity of indoor unit	AU9	13.2 x 2.72 / 13.6 = 2.64 kW	See 3-8-2

*1) : Equation for calculation of capacity of outdoor unit.

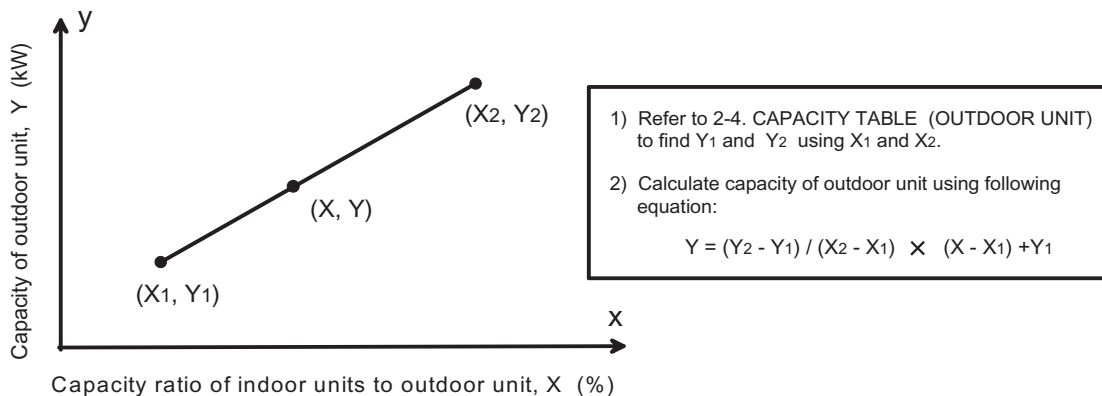

	For (1-1)			For (1-2)		
Total capacity of indoor units	X1= 130%	X = 138.2%	X2 = 140%	X1= 90%	X = 92.1%	X2 = 100%
Capacity of outdoor unit	Y1 = 16.4	Y	Y2 = 16.6	Y1 = 13.6	Y	Y2 = 14.7

↓

Y = 16.56 (kW)

↓

Y = 13.83 (kW)

- 1) If the actual capacity is less than load of room, change to a larger capacity indoor unit.
- 2) Select an optimum capacity of unit and make sure not to select too large to the load.

3-9. REFRIGERANT PIPING LENGTH COMPENSATION CURVE

■ CAPACITY RATIO OF COOLING OPERATION

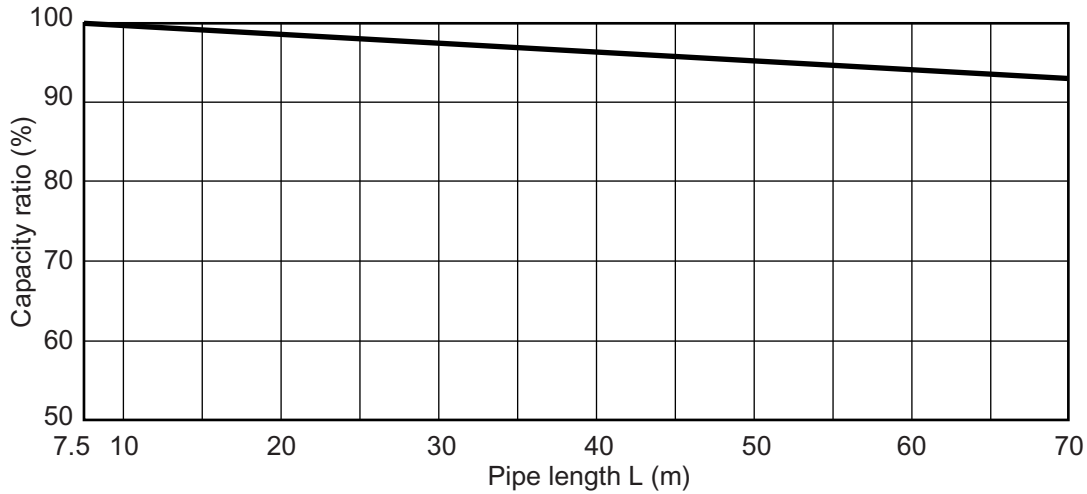

■ CAPACITY RATIO OF HEATING OPERATION

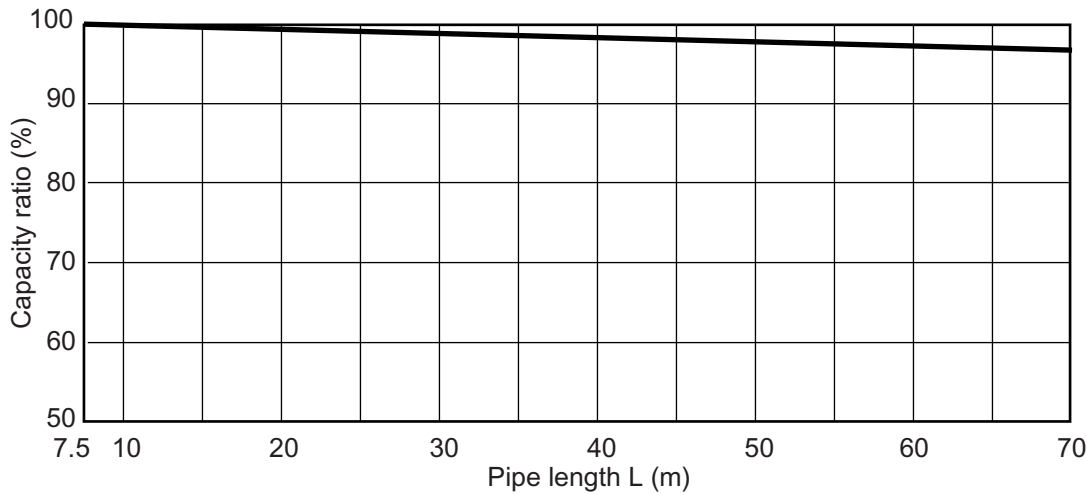

These data are under the rated standard condition.

■ CAUTION

Depending on the pipe length, the set-up of the pipe length switch (on the outdoor unit PCB) is required. If it was set up incorrectly, it leads to the trouble such as insufficient capacity or abnormal pressure.

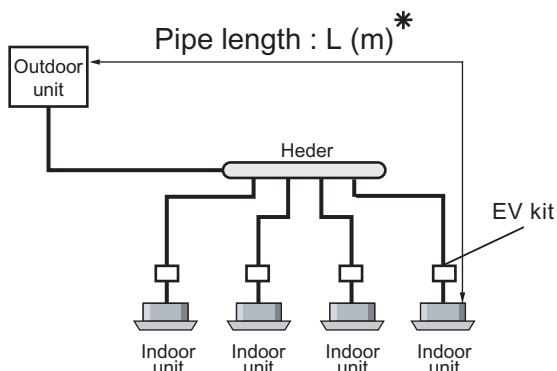

(◆ . . . Factory setting)

DIP SW 6 - 1	DIP SW 6 - 2	Pipe length : L (m)
OFF	OFF	$7.5 \leq L < 50$
ON	ON	$50 \leq L \leq 70$

The pipe lengths shown here are one of the standards. It may differ depending on the system.

* Pipe length means the length between outdoor unit and the farthest indoor unit.

3-10. OPERATION RANGE

Operation mode	Operation range	
	Indoor unit	Outdoor unit
Cooling / Dry	18 to 32 °CDB R. H. 80 % or less	-5 to 43 °CDB
Heating	10 to 30 °CDB	-20 to 21 °CDB

R. H. : Relative Humidity.

OUTDOOR
UNITS

OUTDOOR
UNITS

3-11. SOUND LEVEL

OVERALL

VOLTAGE	OPERATION MODE	SOUND LEVEL
230V	Normal mode (Fan speed : HIGH)	56 dB (A)
	Silent mode (Fan speed : LOW)	51 dB (A)

SOUND LEVEL CHECK POINT

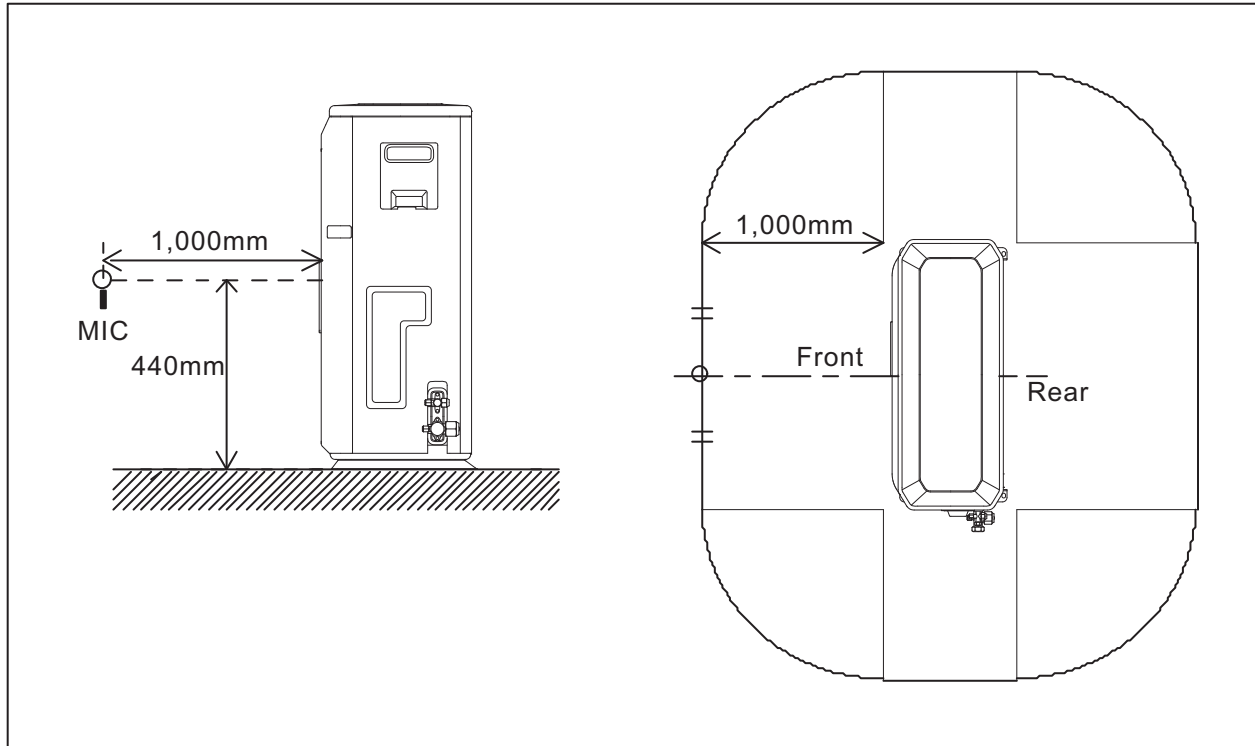

OUTDOOR
UNITS

OUTDOOR
UNITS

■ OCTAVE-BAND LEVEL

230V 50Hz

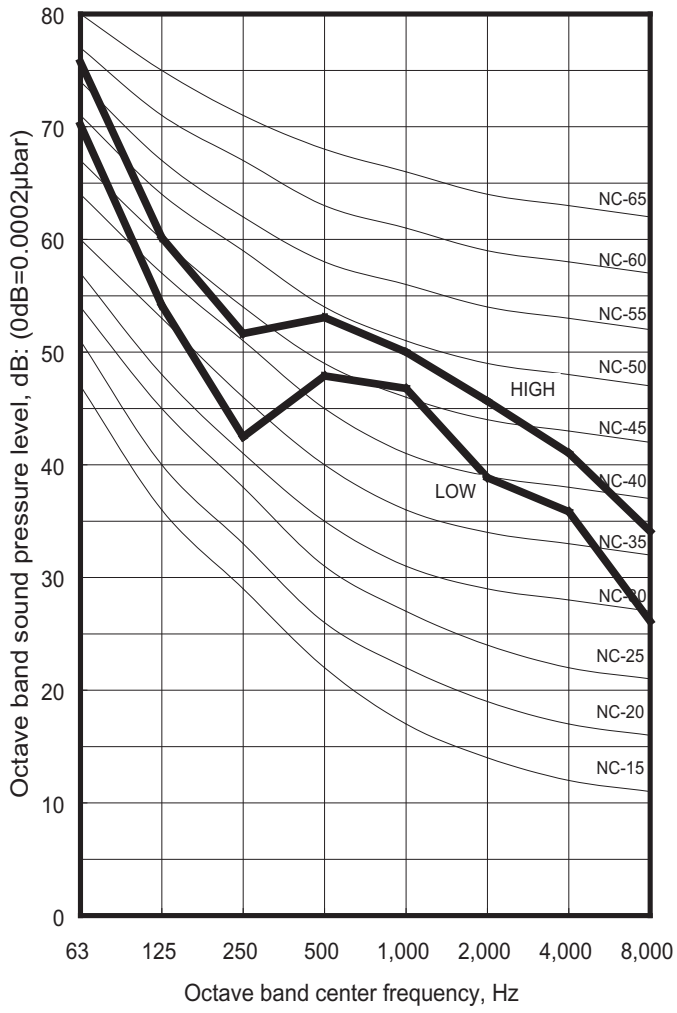

OUTDOOR
UNITS

OUTDOOR
UNITS

3-12. ELECTRIC CHARACTERISTICS

MODEL NAME			AJ*A54L, AJ*A54J, AO*54U, AO*54F	
POWER SUPPLY	ϕ W		Single phase	
	FREQUENCY		Hz	
	VOLTAGE	RATED	V	
		min / MAX		
RATED LOAD CURRENT	RLC	A	20.2	
MAX. LOAD CURRENT	MLC	A	30	
MAX. LOAD INPUT	MLI	kW	5.8	
MAX. FUSE AMP.	FS	A	30	
COMPRESSOR	Rated Load Amp.	RLA	A	19.6
	MOTOR OUTPUT	MO	kW	4.8

• RLC is based on following standard condition.

Indoor : 27°C DB/19°C WB

Outdoor : 35°C DB

- MLC is based on the value of using maximum operation range.
- Always make the air conditioner power supply a special branch circuit and provide a special breaker.
- The capacity of the circuit breaker for leak current should be 30 mA or more.
- The total length of the connection cord should be 150m or shorter.
- If the total length of the connection cord exceeds 100m, keep the length of the connection cord for the indoor units more than 5m.

3-13. SAFETY DEVICES SETTING

MODEL NAME	AJ*A54L, AJ*A54J, AO*54U, AO*54F
PCB FUSE	250V 3.15A / 1A / 0.315A
FAN MOTOR THERMAL PROTECTOR	130°C ± 5°C OFF 83°C ON
HIGH PRESSURE SWITCH	4.2MPa OFF 3.2MPa ON
LOW PRESSURE SWITCH	0.2MPa OFF 0.35MPa ON

AIRSTAGE™

J SERIES

4 . INDOOR UNIT

4-1. MODEL LINE UP

LINE UP

7 types, 30 models ranging from 2.15kW to 14.1kW.

Type		Compact Cassette	Cassette	Compact Duct	Low Static Pressure Duct	Duct	Compact Wall mounted	Wall mounted
Capacity (kW)	Model code							
14.1	54		●					
12.7	45		●			●		
10.5	36		●			●		
8.80	30		●		●	●		●
7.05	25		●		●	●		
6.90	24							●
6.00	22			●				
5.70	20		●					
5.30	18	●		●				●
4.00	14	●		●			●	
3.60	12	●		●			●	
2.80	9	●		●			●	
2.15	7	●		●			●	

APPLICABLE OUTDOOR UNIT

Refrigerant type	Type	Model	MODEL CHANGE CODE
R410A	HEAT PUMP	AJ*A54LCLR AO* 54UJBMR	MODEL CHANGE CODE : B, C
	COOLING ONLY	AJ*A54JCLR AO* 54FJBMR	

MODEL DESIGNATION

● All types except for compact duct type and low static pressure duct type

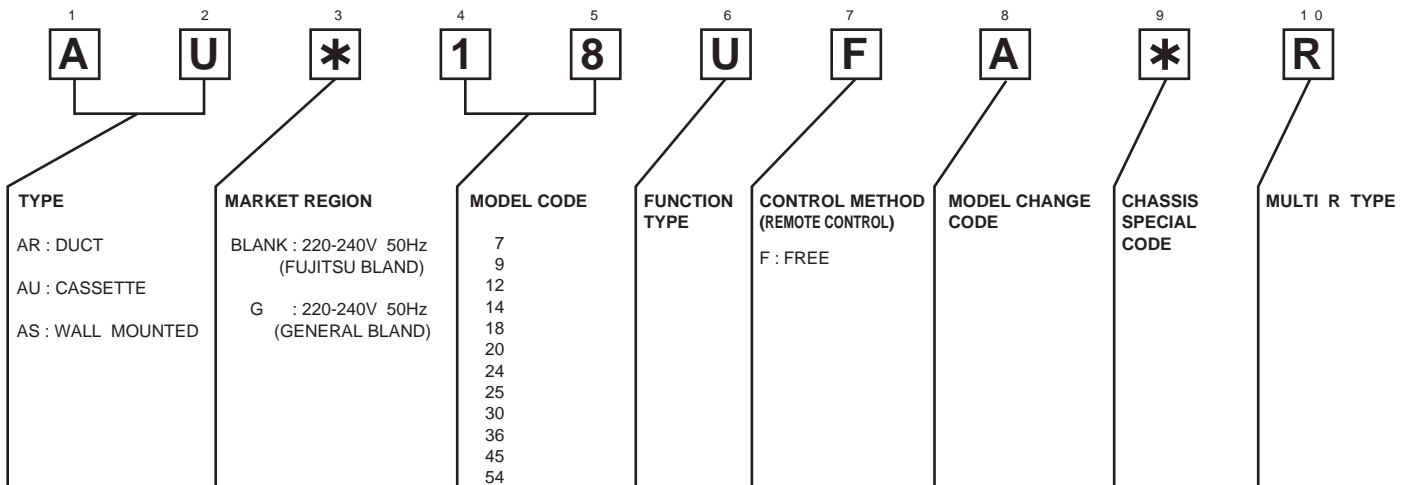

● Compact duct type and low static pressure duct type

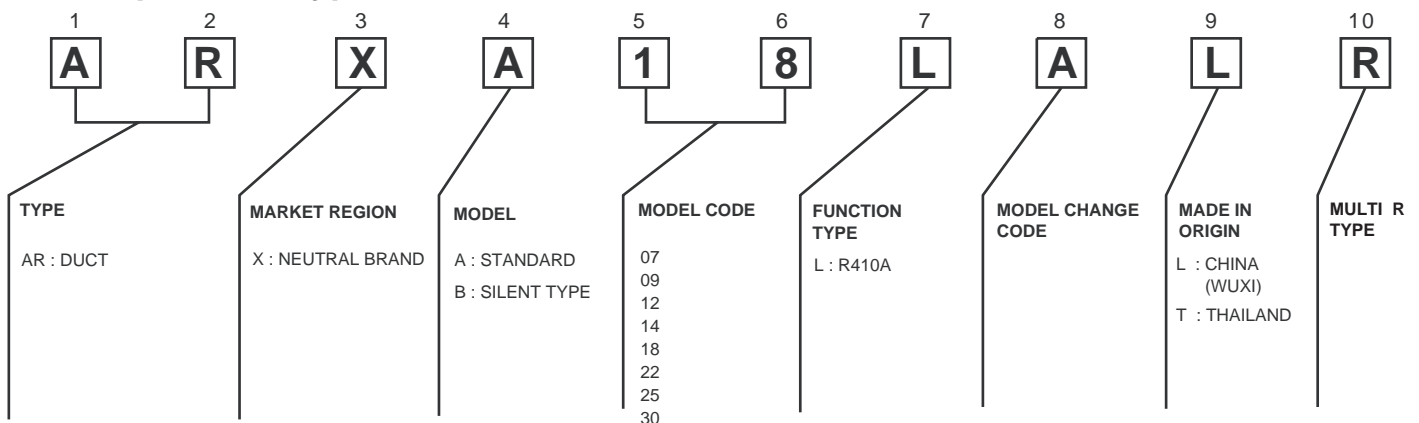

4-2. FEATURE

4-2-1. COMPACT DUCT TYPE

■ MODELS : AR7, AR9, AR12, AR14, AR18, AR22



■ FEATURES

● Compact design

Ultra-thin duct air conditioner for easy installation

● Low noise level

Low noise level is realized for each capacity.

MODEL CODE		7	9	12	14	18	22
Static pressure (Normal/Max.)	Pa	0 / 40					
Volume of air-flow (High/Low)	m ³ / h	420/360	420/360	620/470	620/470	950/620	890/670
Noise level (Low speed)	dB(A)	31	31	27	27	30	34

● Easy to install (universal type)

Ceiling concealed

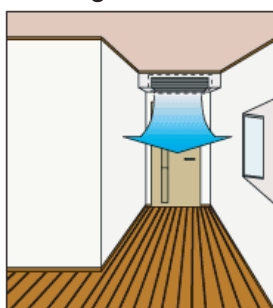

Floor concealed

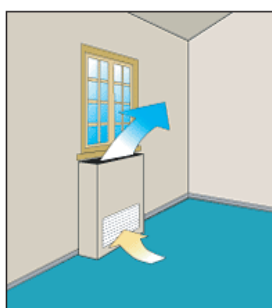

● Installation example



● Two-direction drain piping

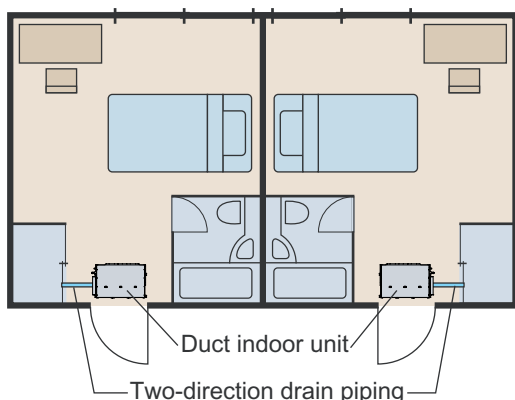

● Filter (Accessory)

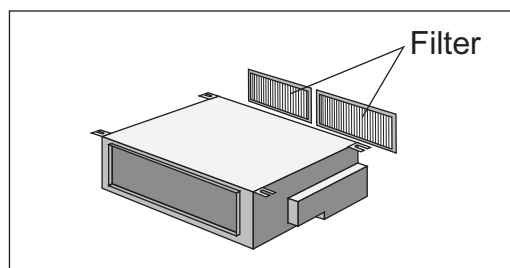

● Others

- * Auto restart
- * Air intake from rear or bottom side

● Optional parts

Remote sensor kit UTD-RS100
 Drain pump unit UTZ-PX1BBA

4-2-2. LOW STATIC PRESSURE DUCT TYPE

■ MODELS : ARXB25, ARXB30

4-2-3. DUCT TYPE

■ MODELS : AR25, AR30, AR36, AR45

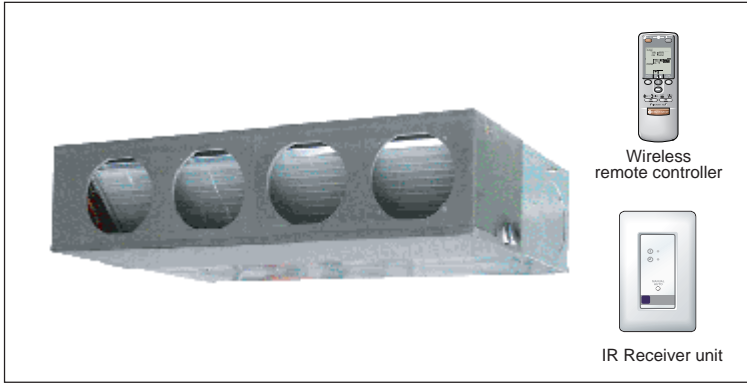

*Wireless remote controller and IR receiver unit is supplied with all duct type indoor units.

■ FEATURES

● Low static pressure duct type

■ Optimum model for hotels or bedrooms

26dB
Low speed

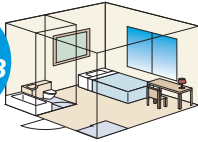

An ultra low-noise model that achieves a quiet interior. Perfect for hotels or bedrooms with limited air duct installation space.

■ Installation styles

Direct air flow installation can be performed. Air intake system can also be chosen.

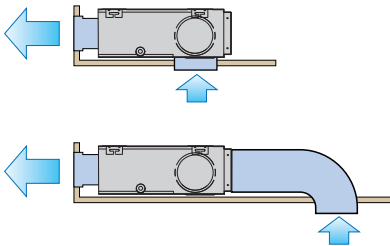

● Duct type

■ Powerful model with a flexible design

Max. 180Pa



With a powerful motor, appropriate for a wide range of static pressure. Flexible air duct installation is possible in a large space such as an office.

■ Installation styles

Embedded Ceiling

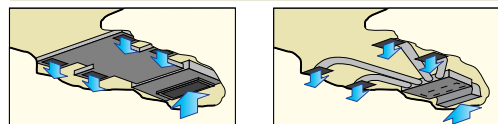

Hanging from Ceiling

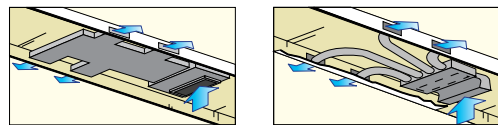

● Savings in space and easy installation

Slim compact design allows for easy installation in narrow ceiling space.

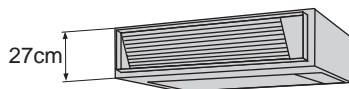

Suspended Installation

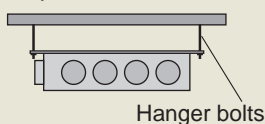

Direct Installation

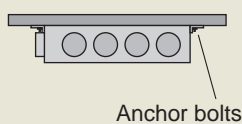

● Two-direction drain piping

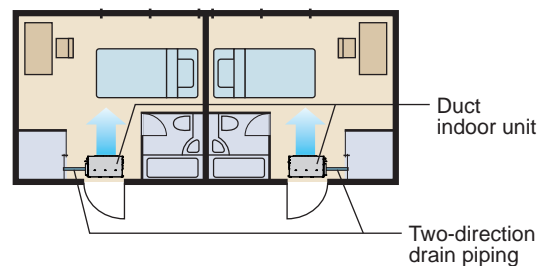

● Optional parts

Flange (square)	UTD-SF045T
Flange (round)	UTD-RF204
Long-life filter	UTD-LF270
Remote sensor unit	UTD-RS100

4-2-4. COMPACT CASSETTE TYPE

■ MODELS : AU7, AU9, AU12, AU14, AU18

- **Applicable grille unit:**

UTG-UD*D-W

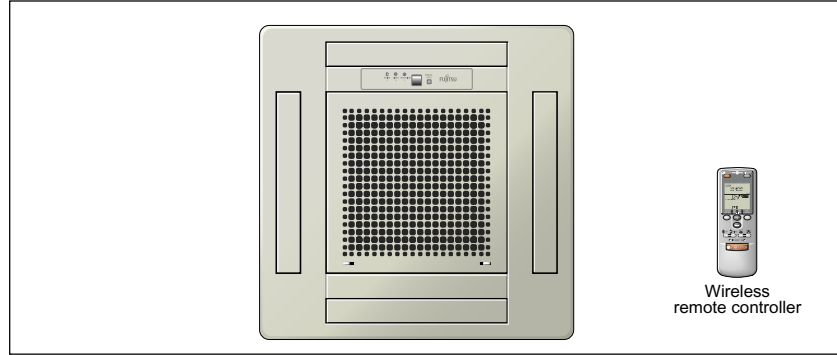

Wireless remote controller

■ FEATURES

- **Compact Design**

This compact air conditioner can be fit to ceiling tiles (600 X 600mm)

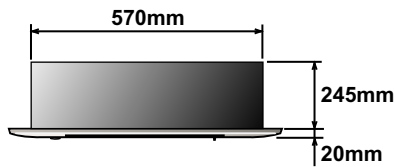

- **Flat & simple design**

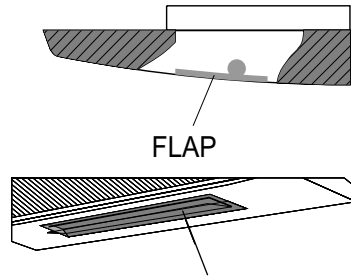

Plastic flap with no velvet coating

Fit to ceiling tiles (600mm x 600mm)

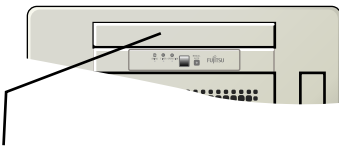

Plastic Flap with no Velvet Coating

- **Auto Air Frow Direction and Auto Swing**

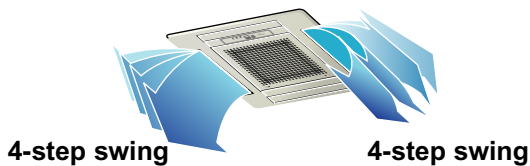

- **4-way air flow system**

You can select 2-way, 3-way or 4-way air flow to suit your needs.

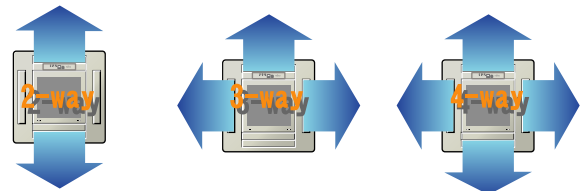

INDOOR UNIT

INDOOR UNIT

● **Easy maintenance**

By putting the Electrical Component box inside the unit, we realized easy maintenance.

● **Simple maintenance**

Wide opening for easy maintenance.

● **Detachable, washable air intake grille**

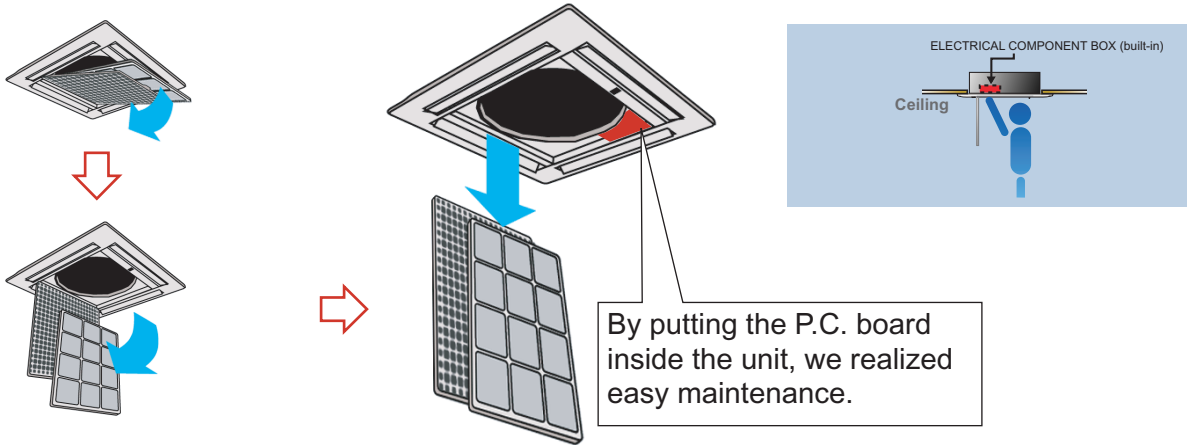

● **Airflow range**

Airflow at floor level is increased by changing the air velocity.

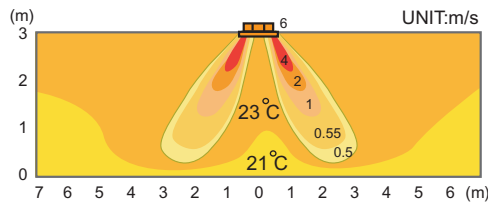

● **Low noise**

Large air volume and low noise achieved by large diameter variable pitch Turbo Fan (Φ298mm) and Φ7 evaporator.

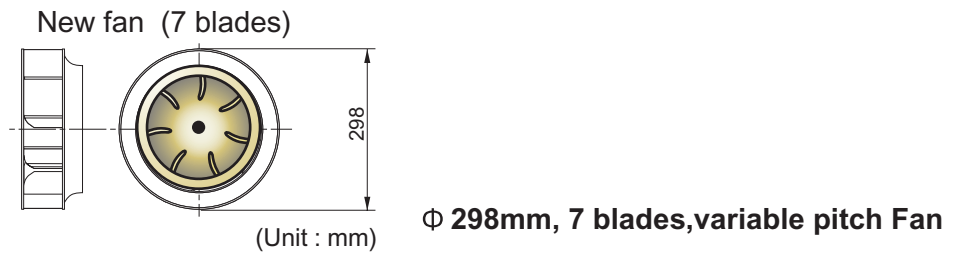

By reducing the noise level of around 100Hz, we realized to reduce the harsh grating noise in actual hearing.

● **Light weight & easy installation**

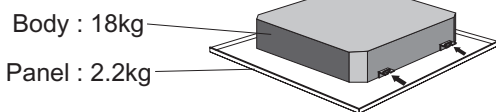

● **Drain water pipe lifted to 400mm**



● **Others**

- * Auto Restart
- * Auto Shut Flaps

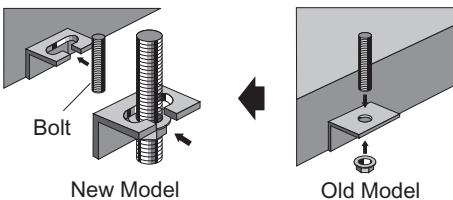

4-2-5. CASSETTE TYPE

MODELS : AU20, AU25, AU30



FEATURES

Flexible installation

Small and compact body allows space saving installation. New mechanism allows the cassette body to move 35mm downward and contributes to keeping the ceiling surface clean.

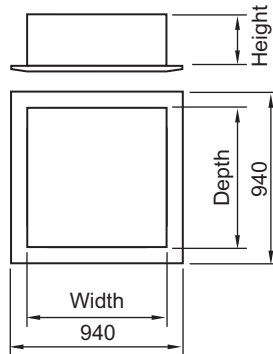

Setting space

Model	AU20, AU25, AU30
Height	200 or 235
Width	830
Depth	830

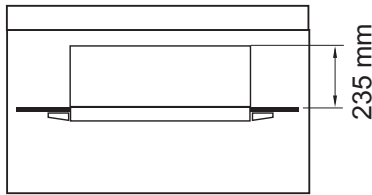

Standard setting

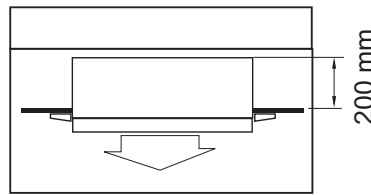

Slender setting

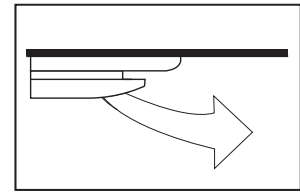

Improved noise level and air distribution

Noise level is lowered dramatically.

- * Improved turbo fan shape (aerodynamic design)
- * Expanded air distribution
- * Low internal resistance
- * Molded fan motor

Improvement of fan blade

Old fan (13 blades)

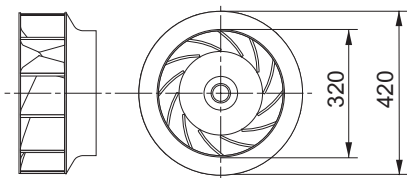

(Unit : mm)



New fan (7 blades)

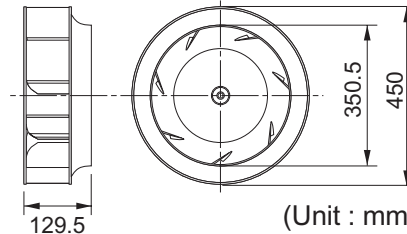

(Unit : mm)

Wide air flow

Larger air flap distributes the outlet air flow a longer distance in the horizontal direction.

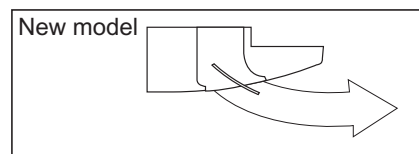
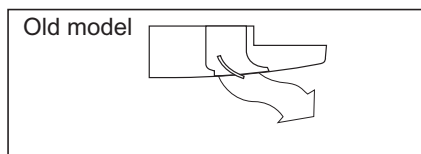

■ MODELS : AU36, AU45, AU54



■ FEATURES

● Flexible installation

Small and compact body allows space saving installation. New mechanism allows the cassette body to move 35mm downward and contributes to keeping the ceiling surface clean.

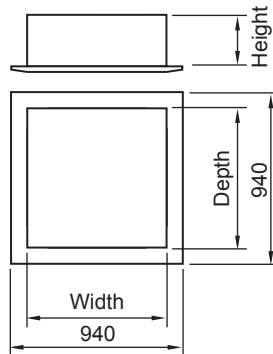

Setting space

Model	AU36, AU45, AU54
Height	250 or 285
Width	830
Depth	830

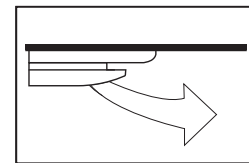
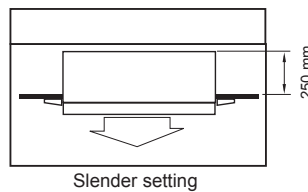
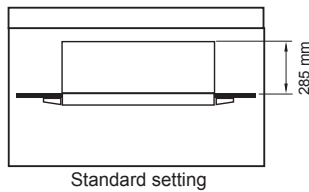

● Improved noise level and air distribution

Noise level is lowered dramatically.

- * Improved turbo fan shape (aerodynamic design)
- * Expanded air distribution
- * Low internal resistance
- * Molded fan motor

● Improvement of fan blade

Old fan (13 blades)

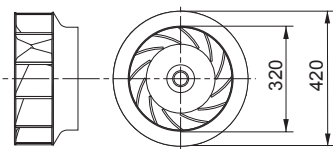

(Unit : mm)



New fan (7 blades)

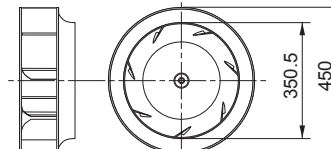

(Unit : mm)

● Wide air flow

Larger air flap distributes the outlet air flow a longer distance in the horizontal direction.

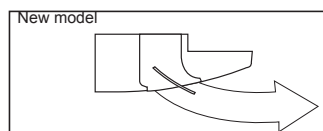
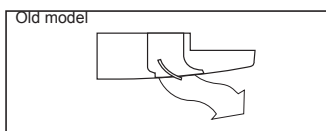

● **Auto air flow direction and auto swing**

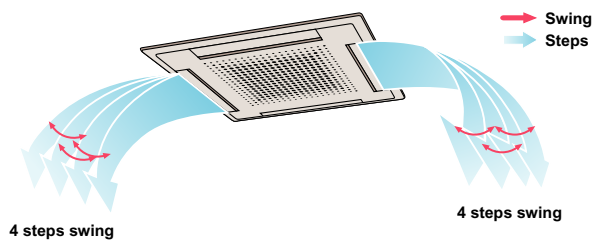

● **4-way air flow system**

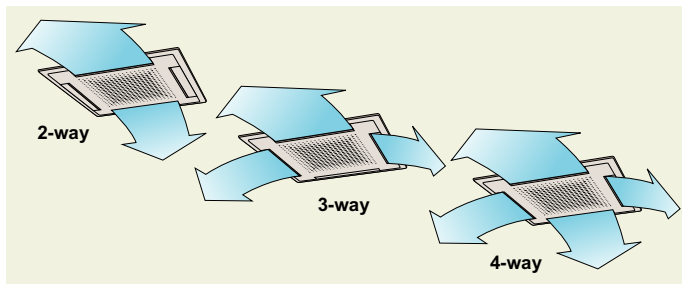

● **Air flow volume can be switched**

High ceiling mode (air flow up) and low-noise (air flow down) can be switched according to the height of the ceiling and other conditions by means of a PCB DIP switch.

● **Duct connection hole opening**

Fresh air can be introduced through this opening.

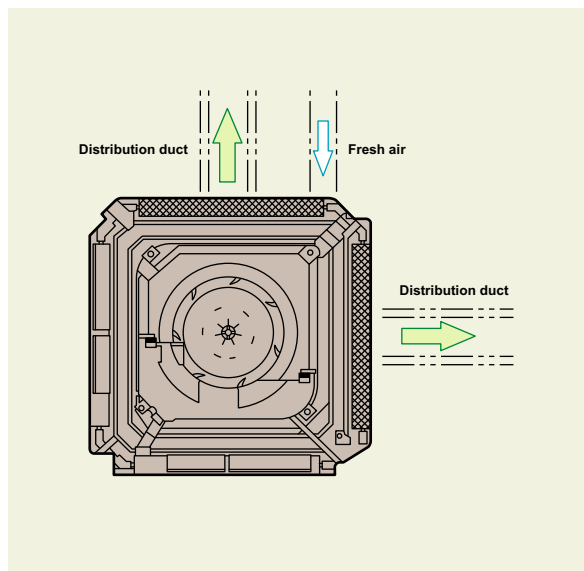

● **Harmonized design**

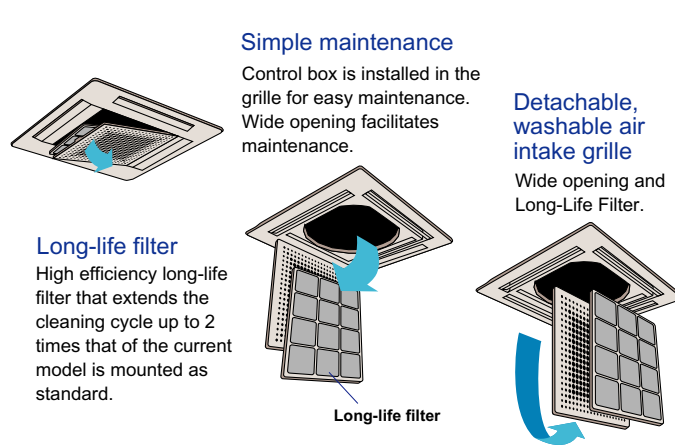

● **Drain water pipe lifted to 800mm**



● **Others**

- * Auto Restart
- * Auto Shut Flaps

Conditioned air can be distributed by means of a distribution duct.

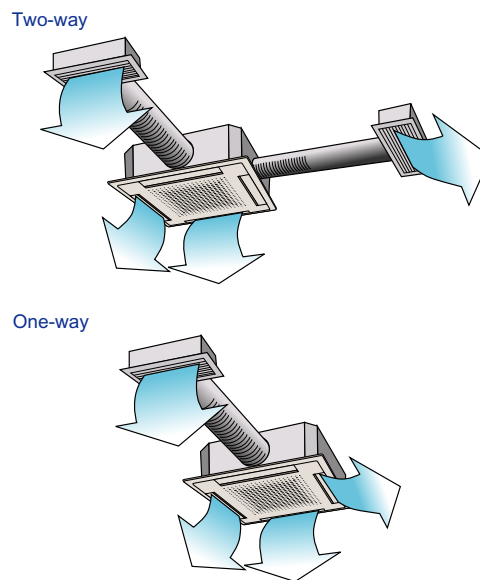

● **Grill design**

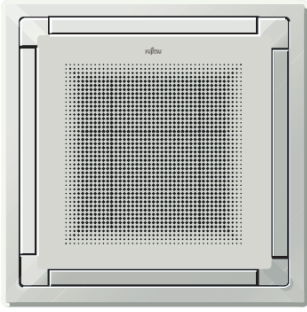

Symmetrical design

New "Punch hole" grill harmonizes with any interior design, even when several units are installed in one room.

● **Easy cleaning**

Thin grill, auto-close flaps without velvet coating and flat surface allow easy cleaning.

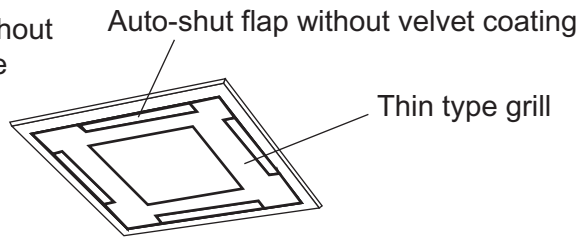

● **Easy installation**

Since the cassette body can be installed using a grill frame, it is easy to fit in the ceiling surface.

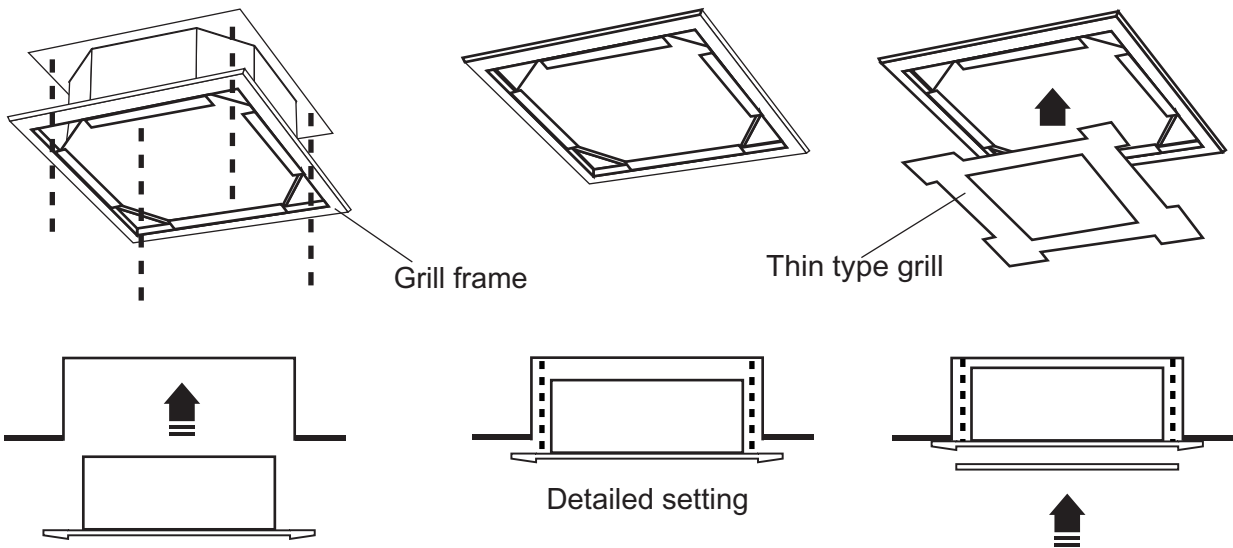

● **Drain water pipe lifted to 800mm**



● **Others**

- * Auto Restart
- * Auto Shut Flaps

INDOOR UNIT

INDOOR UNIT

4-2-6. COMPACT WALL MOUNTED TYPE

MODELS : AS7, AS9, AS12, AS14

- Vertical and horizontal symmetrical design matched to the interior decor
- Compact design

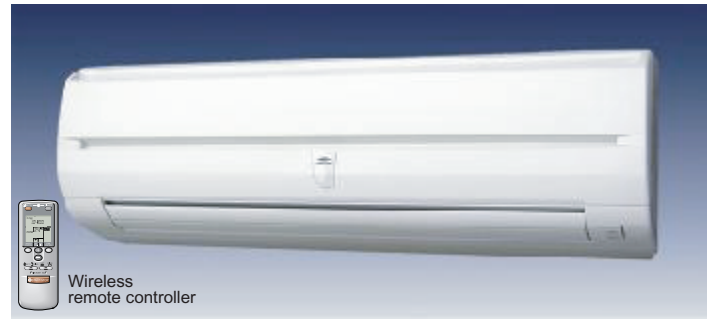

FEATURES

• Fine symmetry design

H257 x W808 x D187 (mm)

• Powerful Output in spite of Small Size

Though the indoor unit is compact, it features a large, high pressure cross fan (90mm diameter) in a center mounted configuration and a lambda type heat exchanger to provide plenty of power.



• Low noise level

Realizing the low noise operation by optimizing the air channel structure.

HIGH	30
LOW	26

Unit : dB(A) AS7

• Washable open panel

Removable and washable panel totally purges mold and dust.

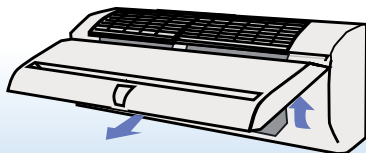

Since the panel is removed and easily washed, the panel is always clean and filter cleaning is also simple.

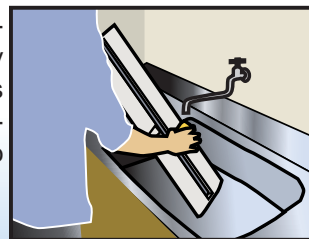

Since there are few bars, only a daily wipe cleans the panel.

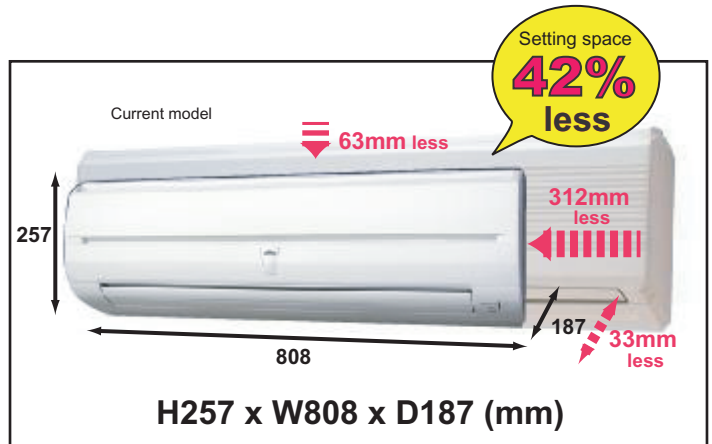
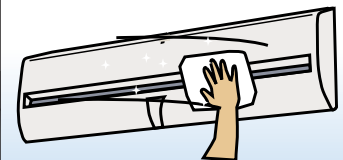

• Auto swing louver

The Auto Swing Louver function ensures that air direction corresponds to the mode selected.

Cooling : 3-step (1-3)

Heating : 6-step (1-6)

- Step
- - - Swing

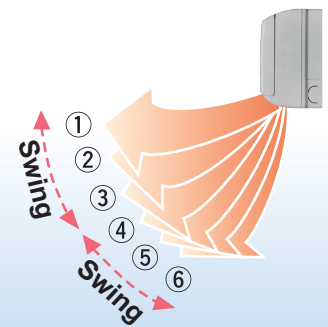

Note : Wired and simple remote controllers are not available for compact wall mounted type indoor units.

4-2-7. WALL MOUNTED TYPE

■ MODELS : AS18, AS24, AS30

- Vertical and horizontal symmetrical design matched to the interior decor
- Easy-to-read center display
- Big wide flaps with a powerful image



■ FEATURES

● Fine symmetry design

H320 x W1,120 x D220 (mm)

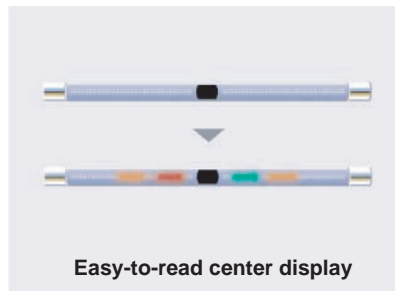

● Low-noise

- High efficiency fan construction ⇒ $\Phi 7$ mm Lambda type evaporator improves the airflow path
- Large air diffuser

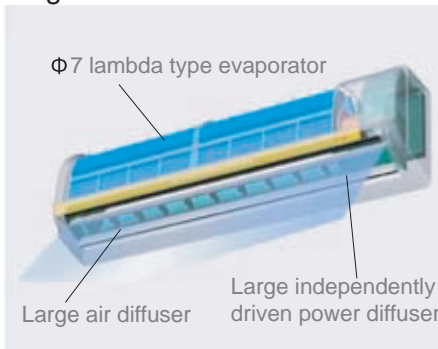

● Other features include continuation of the functions of the existing wall mounted type.

- Double auto swing
- 2-way draining route

● Easier installation

- Expanded work space at bottom of casing
Increases piping space by 15%

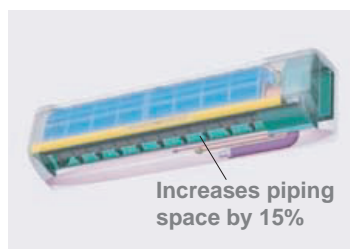

● Pleasant multi-air flow

Effective air flow within a room is achieved by the unique operation of the power diffuser. The angle of the flap can be adjusted in six steps to give draught-free air flow.

Wide air flow realized by unique operation of the power diffuser

Cooling

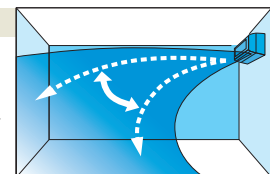
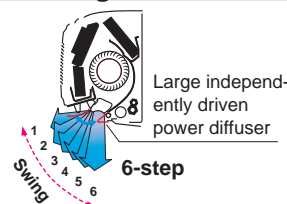

Horizontal concentration and other air direction control

Heating

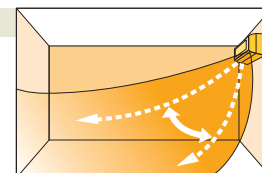
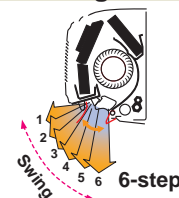

Warm air reaches every corner of the room.



● Others

- * Auto Restart
- * Double auto swing
- * 2-way draining route

4-3. SPECIFICATIONS

4-3-1. COMPACT DUCT TYPE

■ MODELS : AR7, AR9, AR12, AR14, AR18, AR22

Model		AR7	AR9	AR12	AR14	AR18	AR22
Model name		ARXA07 LALR	ARXA09 LALR	ARXA12 LALR	ARXA14 LALR	ARXA18 LBLR	ARXA22 LBLR
Power source		220-240V, 50Hz					
Cooling capacity	[kW]	2.15	2.80	3.50	4.00	5.30	6.00
	[BTU/h]	7,300	9,600	11,900	13,700	18,100	21,100
Heating capacity	[kW]	2.45	3.10	4.10	4.80	5.60	6.30
	[BTU/h]	8,400	10,600	14,000	16,400	19,100	21,500
Input power	[W]	32		49		103	77
Current	[A]	0.20		0.24		0.45	0.36
Maximum current		0.24		0.29		0.54	0.40
Heat exchanger	Coil		Plate fin coil				
	Surface treatment		Hydrophilic coating				
	Rows x stages		2 x 14				3 x 14
	Fin pitch	[mm]	1.3				
	Fin surface area	[m ²]	4.2	7.2		7.2	10.9
Air circulation	High	[m ³ /h]	420	620	950	890	
	Med		390	550	790	780	
	Low		360	470	620	670	
Recommend static pressure	[Pa]	0 to 40					
Fan type x number		Sirocco x 1		Sirocco x 2			
Fan motor output	[W]	10	14	52	36		
Noise level (sound pressure)	High	[dB(A)]	34	33	40	42	
	Med		32	29	35	38	
	Low		31	27	30	34	
Air filter		PP monofilament net (Antibacterial / Deodorization)					
Casing		Galvanized steel sheet					
Dimensions (H x W x D)	Net	[mm]	217 x 663 x 595	217 x 953 x 595			
	Gross		324 x 785 x 686	324 x 1,075 x 686			
Weight	Net	[kg]	18	25			
	Gross		22	29			
Pipe	Diameter	Liquid	Ø6.35				
		Gas	Ø9.52	Ø12.70	Ø15.88		
	Connection method		Flare				
Drain pipe material / Outer dia. (mm) / Inner dia. (mm)		ABS / Outer diameter 26mm / Inner diameter 21.5mm					

Note: Specifications are based on the following conditions.

Cooling: Indoor temperature 27°CDB/19°CWB and outdoor temperature 35°CDB/ 24°CWB

Heating: Indoor temperature 20°CDB/(15°CWB) and outdoor temperature 7°CDB/6°CWB

Standard static pressure : 0 [Pa]. Voltage : 230 [V].

4-3-2. LOW STATIC PRESSURE DUCT TYPE

■ MODELS : ARXB25, ARXB30

Model		ARXB25	ARXB30	
Model name		ARXB25 LATR	ARXB30 LATR	
Power source		220-240V, 50Hz		
Cooling capacity	[kW]	7.05	8.80	
	[BTU/h]	24,100	30,000	
Heating capacity	[kW]	7.85	9.10	
	[BTU/h]	26,800	31,000	
Input power	[W]	155		
Current	[A]	0.70		
Maximum current		0.84		
Heat exchanger	Coil		Plate fin coil	
	Surface treatment		Hydrophilic coating	
	Rows x stages		3 x 14	
	Fin pitch	[mm]	1.4	
	Fin surface area	[m ²]	19.3	
Air circulation	High	[m ³ /h]	1,340	
	Med		1,090	
	Low		970	
Recommend static pressure	[Pa]	0 to 80		
Fan type x number		Sirocco x 2		
Fan motor output	[W]	47		
Noise level (sound pressure)	High	[dB(A)]	33	
	Med		29	
	Low		26	
Air filter		UTD-LF270 (Option) PP honeycomb net, Fungicide type		
Casing		Galvanized steel sheet		
Dimensions (H x W x D)	Net	[mm]	270 x 1,210 x 700	
	Gross		330 x 1,320 x 790	
Weight	Net	[kg]	43	
	Gross		53	
Pipe	Diameter	Liquid	Ø6.35	Ø9.52
		Gas	Ø15.88	
	Connection method		Flare	
Drain pipe material / Outer dia. (mm) / Inner dia. (mm)		Steel / Outer diameter 38.1mm / Inner diameter 35.7mm		

Note: Specifications are based on the following conditions.

Cooling: Indoor temperature 27°CDB/19°CWB and outdoor temperature 35°CDB/ 24°CWB

Heating: Indoor temperature 20°CDB/(15°CWB) and outdoor temperature 7°CDB/6°CWB

Standard static pressure : 0 [Pa]. Voltage : 230 [V].

4-3-3. DUCT TYPE

■ MODELS : AR25, AR30, AR36, AR45

Model		AR25	AR30	AR36	AR45
Model name		AR25 UFAAR	AR30 UFAAR	AR36 UFAAR	AR45 UFAAR
Power source		220-240V, 50Hz			
Cooling capacity	[kW]	7.05	8.80	10.5	12.7
	[BTU/h]	24,100	30,000	36,000	43,500
Heating capacity	[kW]	7.85	9.10	10.7	13.7
	[BTU/h]	26,800	31,000	36,500	47,000
Input power	[W]	155		315	
Current	[A]	0.68		1.44	
Maximum current		0.84		1.84	
Heat exchanger	Coil		Plate fin coil		
	Surface treatment		Hydrophilic coating		
	Rows x stages		3 x 14		4 x 14
	Fin pitch	[mm]	1.4		1.4
	Fin surface area	[m ²]	14.4		19.3
Air circulation	High	[m ³ /h]	1,200		2,200
	Med		1,100		2,000
	Low		1,000		1,800
Recommend static pressure	[Pa]	30 to 160		30 to 180	
Fan type x number		Sirocco x 2			
Fan motor output	[W]	77		275	
Noise level (sound pressure)	High	[dB(A)]	44		49
	Med		42		47
	Low		40		45
Air filter		UTD-LF270 (Option) PP honeycomb net, Fungicide type			
Casing		Galvanized steel sheet			
Dimensions (H x W x D)	Net	[mm]	270 x 1,210 x 700		
	Gross		330 x 1,320 x 790		
Weight	Net	[kg]	43		45
	Gross		53		55
Pipe	Diameter	Liquid	Ø6.35	Ø9.52	
		Gas	Ø15.88		Ø19.05
	Connection method		Flare		
Drain pipe material / Outer dia. (mm) / Inner dia. (mm)		Steel / Outer diameter 38.1mm / Inner diameter 35.7mm			

Note: Specifications are based on the following conditions.

Cooling: Indoor temperature 27°CDB/19°CWB and outdoor temperature 35°CDB/ 24°CWB

Heating: Indoor temperature 20°CDB/(15°CWB) and outdoor temperature 7°CDB/6°CWB

Standard static pressure : 100 [Pa]. Voltage : 230 [V].

4-3-4. COMPACT CASSETTE TYPE

■ MODELS : AU7, AU9, AU12, AU14, AU18

Model		AU7	AU9	AU12	AU14	AU18
Model name		AU7 UFAAR	AU9 UFAAR	AU12 UFAAR	AU14 UFAAR	AU18 UFAAR
Power source		220-240V, 50Hz				
Cooling capacity	[kW]	2.15	2.80	3.60	4.00	5.00
	[BTU/h]	7,400	9,600	12,300	13,700	17,100
Heating capacity	[kW]	2.45	3.10	4.10	4.50	5.45
	[BTU/h]	8,400	10,600	14,000	15,400	18,600
Input power	[W]	28		52		50
Current	[A]	0.13		0.23		0.22
Maximum current		0.15		0.27		0.26
Heat exchanger	Coil		Plate fin coil			
	Surface treatment		High hydrophilic coating			
	Rows x stages		2 x 8			
	Fin pitch	[mm]	1.4			
	Fin surface area	[m ²]	7.4			
Air circulation	High	[m ³ /h]	530		640	
	Med		480		540	
	Low		410		470	
Fan type x number		Turbo x 1				
Fan motor output	[W]	9		10		15
Noise level (sound pressure)	High	[dB(A)]	38		44	
	Med		35		38	
	Low		31		35	
Air filter		PP honeycomb net (Anti-mold)				
Fujitsu Grille color		UTG-UDYD-W (Option), White (5Y9/0.5NN)				
General Grille color		UTG-UDGD-W (Option), White (5Y9/0.5NN)				
Casing		Galvanized steel sheet				
Dimensions (H x W x D)	Net	[mm]	230 x 570 x 570			
	Gross		310 x 710 x 750			
Weight	Net	[kg]	18			
	Gross		23			
Pipe	Diameter	Liquid	Ø6.35			
		Gas	Ø9.52		Ø12.70	
	Connection method		Flare			
Drain pipe material / Outer dia. (mm) / Inner dia. (mm)		PS / Outer diameter 37mm / Inner diameter 32mm				

Note: Specifications are based on the following conditions.

Cooling: Indoor temperature 27°CDB/19°CWB and outdoor temperature 35°CDB/ 24°CWB.

Heating: Indoor temperature 20°CDB/(15°CWB) and outdoor temperature 7°CDB/6°CWB.

Voltage : 230 [V].

4-3-5. CASSETTE TYPE

■ MODELS : AU20, AU25, AU30

Model		AU20	AU25	AU30	
Model name		AU20 UFARR	AU25 UFARR	AU30 UFARR	
Power source		220-240V, 50Hz			
Cooling capacity	[kW]	5.70	7.05	8.80	
	[BTU/h]	19,500	24,100	30,000	
Heating capacity	[kW]	5.80	7.85	9.10	
	[BTU/h]	19,800	26,800	31,100	
Input power	[W]	117	129	142	
Current	[A]	0.76	0.80	0.84	
Maximum current		0.91	0.96	1.00	
Heat exchanger	Coil		Plate fin coil		
	Surface treatment		Hydrophilic coating		
	Rows x stages		2 x (10 & 8) + 2 x (10 & 8)		
	Fin pitch	[mm]	1.3		
	Fin surface area	[m ²]	14.4		
Air circulation	High	[m ³ /h]	1,030	1,170	1,270
	Med		850	970	1,070
	Low		680	770	880
Fan type x number		Turbo x 1			
Fan motor output		[W]	42		
Noise level (sound pressure)	High	[dB(A)]	42	42	45
	Med		38	40	42
	Low		37	39	39
Air filter		PP honeycomb net (Anti-mold)			
Grille color		White (5Y9/0.5NN)			
Casing		Galvanized steel sheet			
Dimensions (H x W x D)	Net	[mm]	246 x 830 x 830		
	Gross		385 x 1,045 x 1,015		
Weight	Net	[kg]	34		
	Gross		45		
Pipe	Diameter	Liquid	Ø6.35	Ø9.52	
		Gas	Ø15.88		
	Connection method		Flare		
Drain pipe material / Outer dia. (mm) / Inner dia. (mm)		ABS / Outer diameter 37mm / Inner diameter 32mm			

Note: Specifications are based on the following conditions.

Cooling: Indoor temperature 27°CDB/19°CWB and outdoor temperature 35°CDB/ 24°CWB.

Heating: Indoor temperature 20°CDB/(15°CWB) and outdoor temperature 7°CDB/6°CWB.

Voltage : 230 [V].

■ MODELS : AU36, AU45, AU54

Model		AU36	AU45	AU54	
Model name		AU36 UFASR	AU45 UFASR	AU54 UFASR	
Power source		220-240V, 50Hz			
Cooling capacity	[kW]	10.5	12.7	14.1	
	[BTU/h]	35,800	43,400	48,100	
Heating capacity	[kW]	10.7	13.7	15.8	
	[BTU/h]	36,500	46,800	53,900	
Input power	[W]	175	190	219	
Current	[A]	0.92	0.94	0.95	
Maximum current		1.10	1.12	1.14	
Heat exchanger	Coil		Plate fin coil		
	Surface treatment		Hydrophilic coating		
	Rows x stages		3 x 12 + 3 x 12		
	Fin pitch	[mm]	1.4		
	Fin surface area	[m ²]	24.0		
Air circulation	High	[m ³ /h]	1,500	1,650	1,780
	Med		1,300	1,450	1,550
	Low		1,100	1,200	1,300
Fan type x number		Turbo x 1			
Fan motor output	[W]	90			
Noise level (sound pressure)	High	[dB(A)]	48	49	52
	Med		44	47	49
	Low		41	43	45
Air filter		PP honeycomb net (Anti-mold)			
Grille color		White (5Y9/05NN)			
Casing		Galvanized steel sheet			
Dimensions (H x W x D)	Net	[mm]	296 x 830 x 830		
	Gross		435 x 1,045 x 1,015		
Weight	Net	[kg]	40		
	Gross		53		
Pipe	Diameter	Liquid	Ø9.52		
		Gas	Ø19.05		
	Connection method		Flare		
Drain pipe material / Outer dia. (mm) / Inner dia. (mm)		ABS / Outer diameter 37mm / Inner diameter 32mm			

Note: Specifications are based on the following conditions.

Cooling: Indoor temperature 27°CDB/19°CWB and outdoor temperature 35°CDB/ 24°CWB.

Heating: Indoor temperature 20°CDB/(15°CWB) and outdoor temperature 7°CDB/6°CWB.

Voltage : 230 [V].

4-3-6. COMPACT WALL MOUNTED TYPE

■ MODELS : AS7, AS9, AS12, AS14

Model		AS7	AS9	AS12	AS14
Model name		AS7 UFADR	AS9 UFADR	AS12 UFADR	AS14 UFADR
Power source		220-240V, 50Hz			
Cooling capacity	[kW]	2.15	2.80	3.50	3.80
	[BTU/h]	7,400	9,600	11,900	13,000
Heating capacity	[kW]	2.45	3.10	4.10	4.50
	[BTU/h]	8,400	10,600	14,000	15,400
Input power	[W]	26	33	40	
Current	[A]	0.15	0.17	0.21	
Maximum current		0.18	0.21	0.24	
Heat exchanger	Coil		Plate fin coil		
	Surface treatment		High hydrophilic coating		
	Rows x stages		2 x 12		
	Fin pitch	[mm]	1.45		
	Fin surface area	[m ²]	5.0		
Air circulation	High	[m ³ /h]	410	500	540
	Med		370	450	510
	Low		350	410	480
Fan type x number		Cross Flow x 1			
Fan motor output		[W]	13		
Noise level (sound pressure)	High	[dB(A)]	30	36	39
	Med		27	33	37
	Low		26	30	34
Air filter		PP honeycomb (Antibacterial and mold proofing)			
Casing color		White (10Y8.5/0.5NN)			
Dimensions (H x W x D)	Net	[mm]	257 x 808 x 187		
	Gross		270 x 850 x 310		
Weight	Net	[kg]	8		
	Gross		10		
Pipe	Diameter	Liquid	Ø6.35		
		Gas	Ø9.52	Ø12.70	
	Connection method		Flare		
Drain pipe material / Outer dia. (mm) / Inner dia. (mm)		With 620mm drain hose, PVC / Outer diameter 16.2-17mm / Inner diameter 12mm			

Note: Specifications are based on the following conditions.

Cooling: Indoor temperature 27°CDB/19°CWB and outdoor temperature 35°CDB/ 24°CWB.

Heating: Indoor temperature 20°CDB/(15°CWB) and outdoor temperature 7°CDB/6°CWB.

Voltage : 230 [V].

4-3-7. WALL MOUNTED TYPE

■ MODELS : AS18, AS24, AS30

Model		AS18	AS24	AS30	
Model name		AS18 UFAJR	AS24 UFAJR	AS30 UFAJR	
Power source		220-240V, 50Hz			
Cooling capacity	[kW]	5.40	6.90	8.00	
	[BTU/h]	18,400	23,600	27,300	
Heating capacity	[kW]	5.60	7.80	8.80	
	[BTU/h]	19,100	26,600	30,000	
Input power	[W]	38	50	60	
Current	[A]	0.18	0.24	0.28	
Maximum current		0.22	0.29	0.34	
Heat exchanger	Coil		Plate fin coil		
	Surface treatment		High hydrophilic coating		
	Rows x stages		2 x 16	2x16 + 1x4	
	Fin pitch	[mm]	1.2	1.2 & 1.4	
	Fin surface area	[m ²]	11.0	12.2	
Air circulation	High	[m ³ /h]	840	950	1,050
	Med		700	800	940
	Low		600	670	780
Fan type X number		Cross Flow x 1			
Fan motor output	[W]	38			
Noise level (sound pressure)	High	[dB(A)]	42	45	48
	Med		39	41	45
	Low		35	37	41
Air filter		PP monofilament net (Deodorization, Anti-mold)			
Casing color		White (10BG9.25/0.5NN)			
Dimensions (H x W x D)	Net	[mm]	320 x 1,120 x 220		
	Gross		348 x 1,240 x 427		
Weight	Net	[kg]	16		
	Gross		22		
Pipe	Diameter	Liquid	Ø6.35	Ø9.52	
		Gas	Ø15.88		
	Connection method		Flare		
Drain pipe material / Outer dia. (mm) / Inner dia. (mm)		With 670mm drain hose, PVC / Outer diameter 16mm / Inner diameter 12mm			

Note: Specifications are based on the following conditions.

Cooling: Indoor temperature 27°CDB/19°CWB and outdoor temperature 35°CDB/ 24°CWB.

Heating: Indoor temperature 20°CDB/(15°CWB) and outdoor temperature 7°CDB/6°CWB.

Voltage : 230 [V].

4-4. ELECTRIC CHARACTERISTICS

■ COMPACT DUCT TYPE

Model name	Input (W)	Current (A)	Max Current (A) (MLC)
AR	7	32	0.20
	9	32	0.20
	12	49	0.24
	14	49	0.24
	18	103	0.45
	22	77	0.36

■ LOW STATIC PRESSURE DUCT TYPE

Model name	Input (W)	Current (A)	Max Current (A) (MLC)
AR	25	155	0.70
XB	30	155	0.70

■ DUCT TYPE

Model name	Input (W)	Current (A)	Max Current (A) (MLC)
AR	25	155	0.68
	30	155	0.68
	36	315	1.44
	45	315	1.44

■ COMPACT CASSETTE TYPE

Model name	Input (W)	Current (A)	Max Current (A) (MLC)
AU	7	28	0.13
	9	28	0.13
	12	52	0.23
	14	52	0.23
	18	50	0.22

■ CASSETTE TYPE

Model name	Input (W)	Current (A)	Max Current (A) (MLC)
AU	20	117	0.76
	25	129	0.80
	30	142	0.84
	36	175	0.92
	45	190	0.94
	54	219	0.95

Note: The data of input, current and max. current are based on the following conditions.
Cooling: Indoor temperature 27°CDB/19°CWB and outdoor temperature 35°CDB/ 24°CWB.
Heating: Indoor temperature 20°CDB/(15°CWB) and outdoor temperature 7°CDB/6°CWB.
Standard static pressure : 0[Pa] (AR7 - AR22, ARXB25,ARXB30) , 100[Pa] (AR25 - AR45).
Voltage : 230 [V]

■ COMPACT WALL MOUNTED TYPE

Model name		Input (W)	Current (A)	Max Current (A) (MLC)
AS	7	26	0.15	0.18
	9	33	0.17	0.21
	12	40	0.21	0.24
	14	40	0.21	0.24

■ WALL MOUNTED TYPE

Model name		Input (W)	Current (A)	Max Current (A) (MLC)
AS	18	38	0.18	0.22
	24	50	0.24	0.29
	30	60	0.28	0.34

Note: The data of input, current and max. current are based on the following conditions.
Cooling: Indoor temperature 27°CDB/19°CWB and outdoor temperature 35°CDB/ 24°CWB.
Heating: Indoor temperature 20°CDB/(15°CWB) and outdoor temperature 7°CDB/6°CWB.
Voltage : 230 [V].

4-5. DIMENSIONS

4-5-1. COMPACT DUCT TYPE

■ MODELS : AR7, AR9

(Unit : mm)

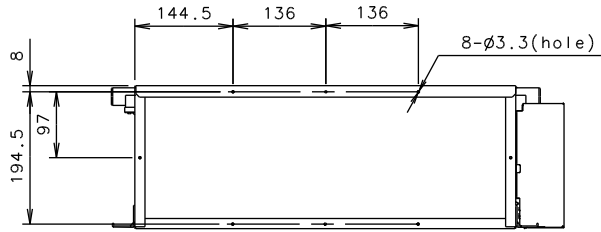

Rear view

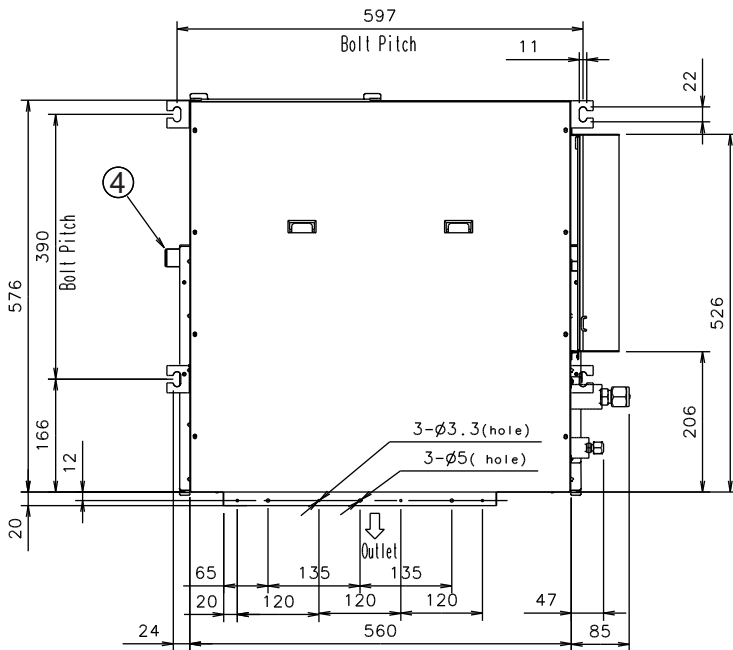

Top view

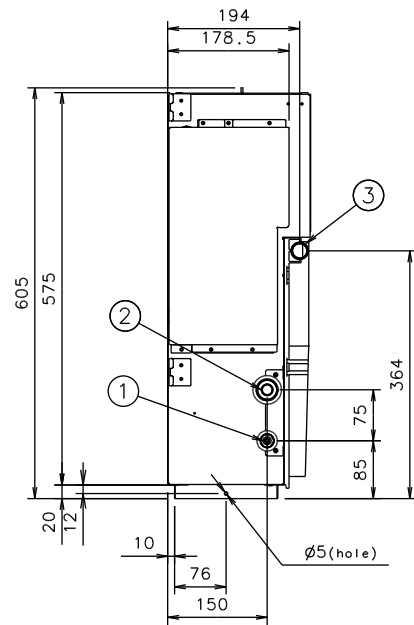

Side view

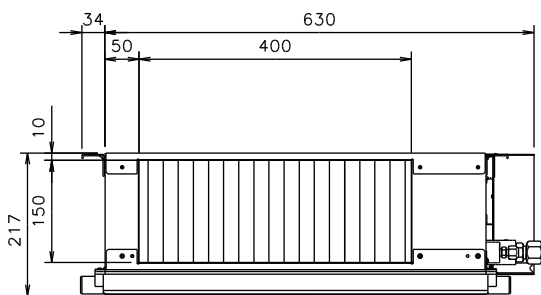

Front view

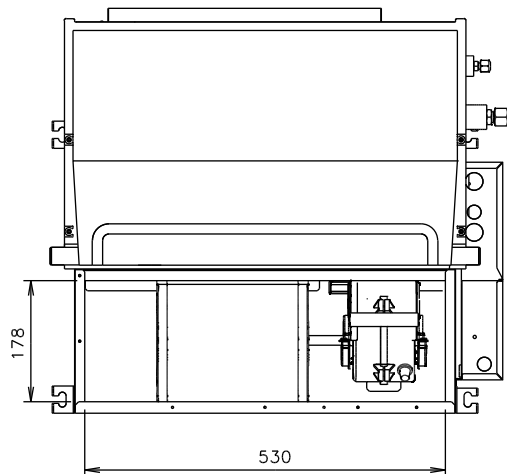

Bottom view

			AR7, AR9
①	Refrigerant pipe flare connection	Liquid	Ø 6.35mm
②		Gas	Ø 9.52mm
③ ④	Drain pipe connection	Drain pipe	I.D. 21.5mm ; O.D. 26mm

■ BIRD'S-EYE VIEW

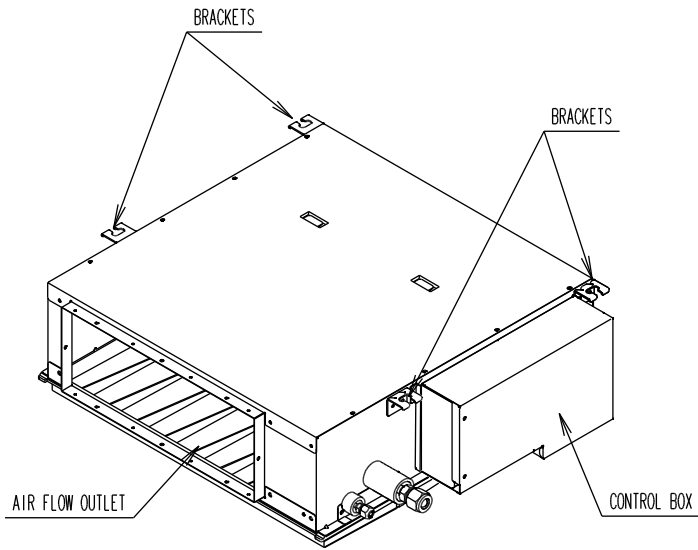

■ MAINTENANCE HOLE *1

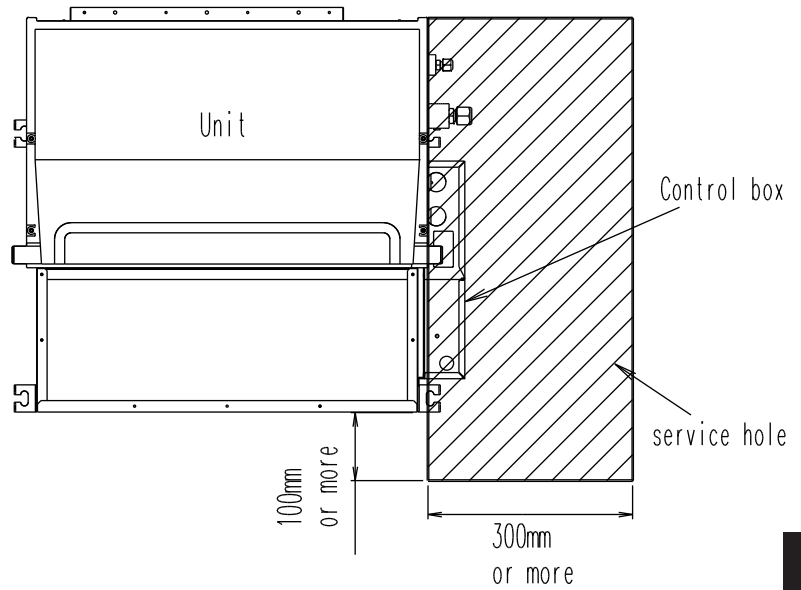

■ MOUNTING POSITION *1

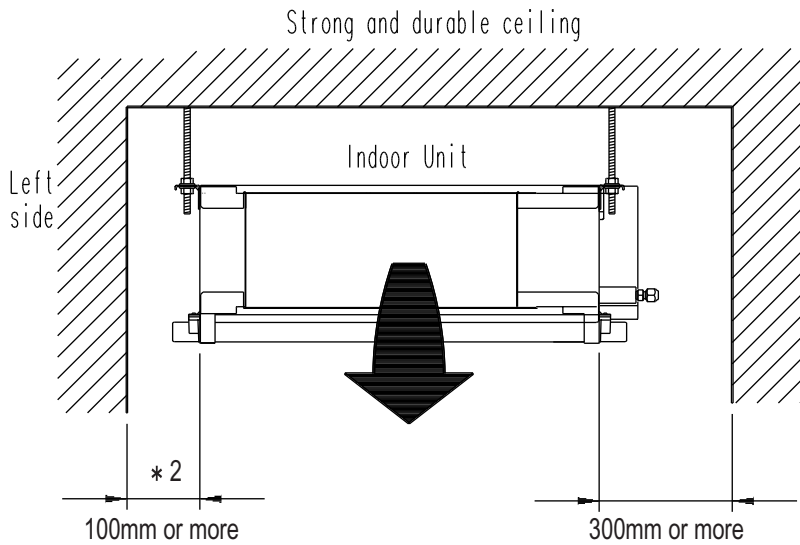

* 1 When drain pump is used, leave the space required for service and maintenance (Refer to 5-6-6. DRAIN PUMP UNIT)

* 2 When drain hose is connected, the required dimension is 150mm or more.

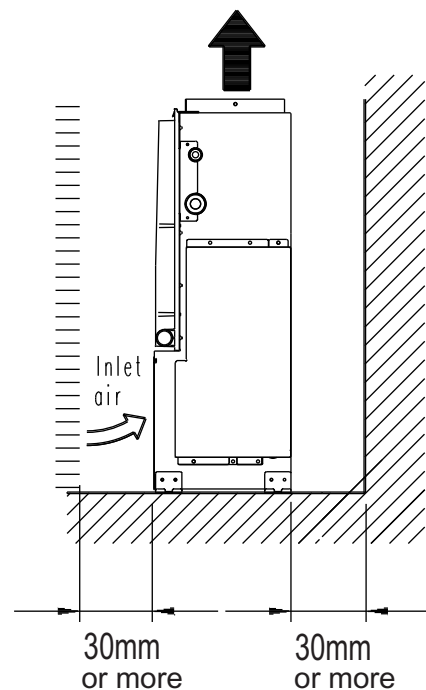
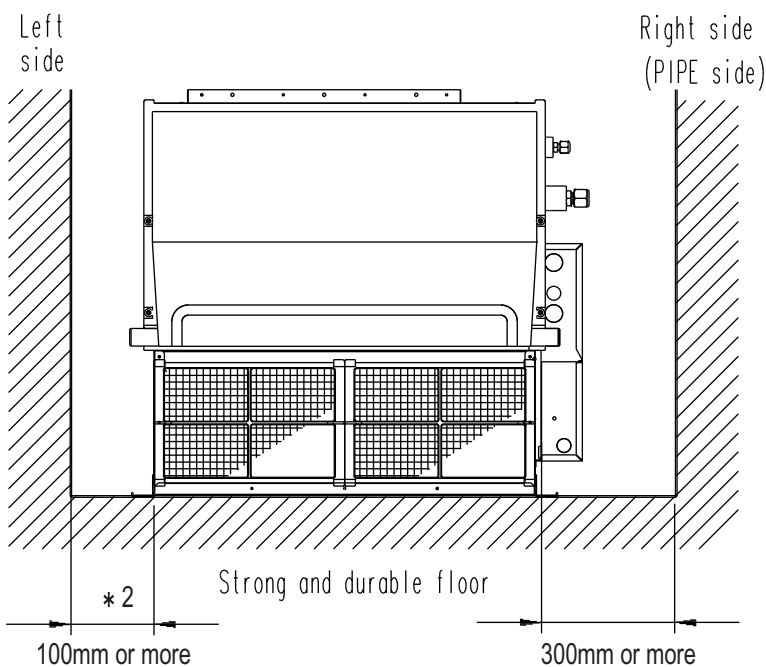

INDOOR UNIT

INDOOR UNIT

MODELS : AR12, AR14, AR18, AR22

(Unit : mm)

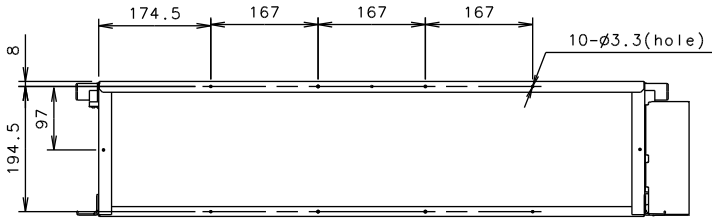

Rear view

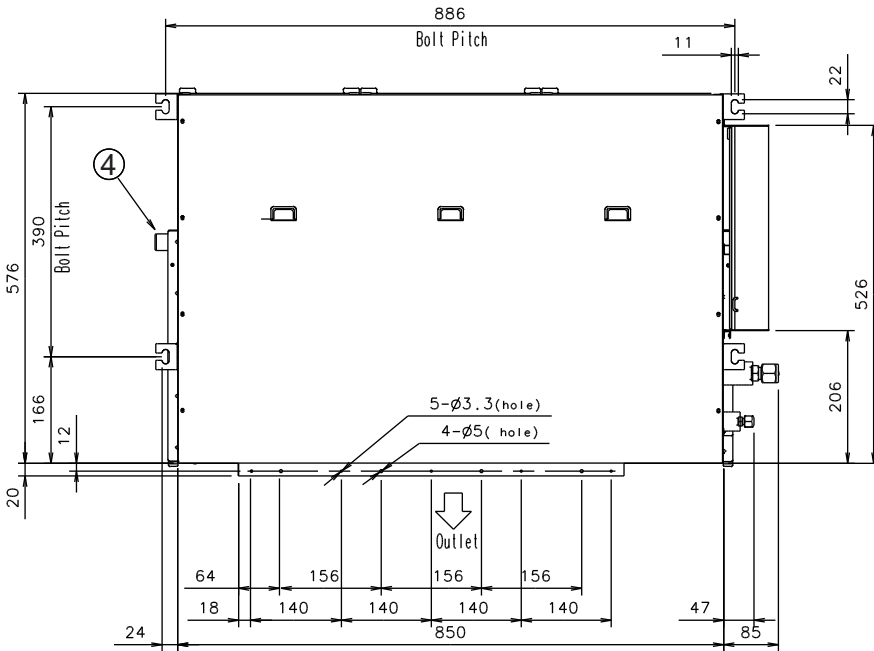

Top view

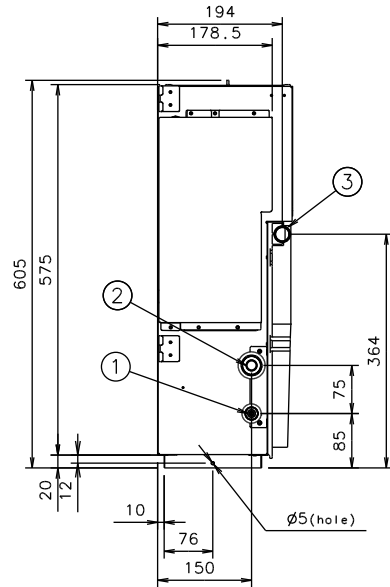

Side view

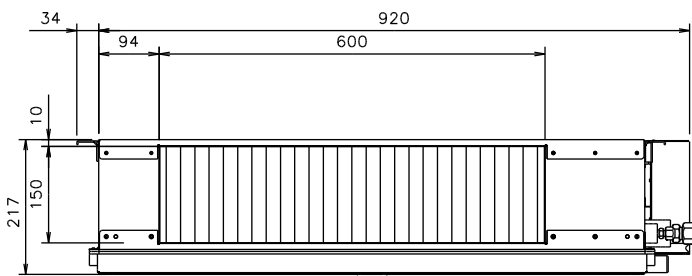

Front view

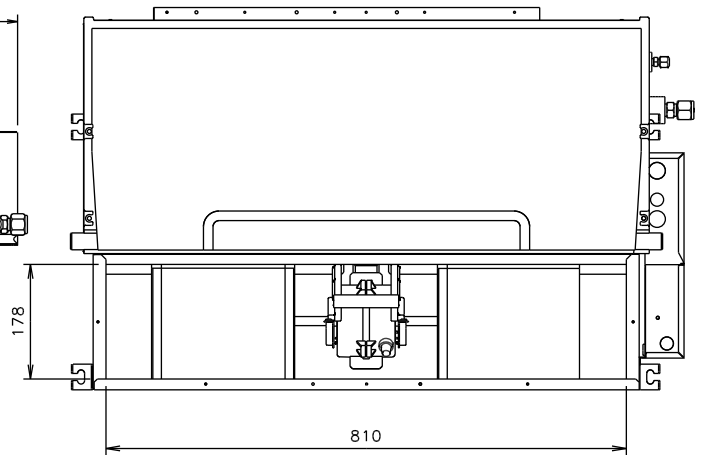

Bottom view

			AR12, AR14	AR18, AR22
①	Refrigerant pipe flare connection	Liquid	ϕ 6.35mm	ϕ 6.35mm
②		Gas	ϕ 12.70mm	ϕ 15.88mm
③ ④	Drain pipe connection	Drain pipe	I.D. 21.5mm ; O.D. 26mm	

■ BIRD'S-EYE VIEW

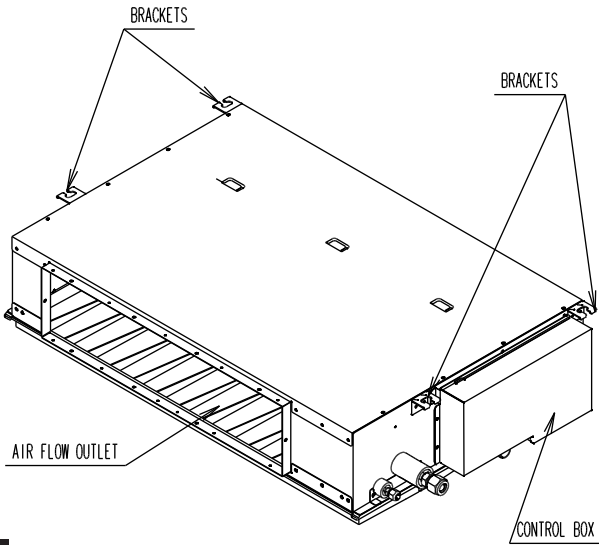

■ MAINTENANCE HOLE *1

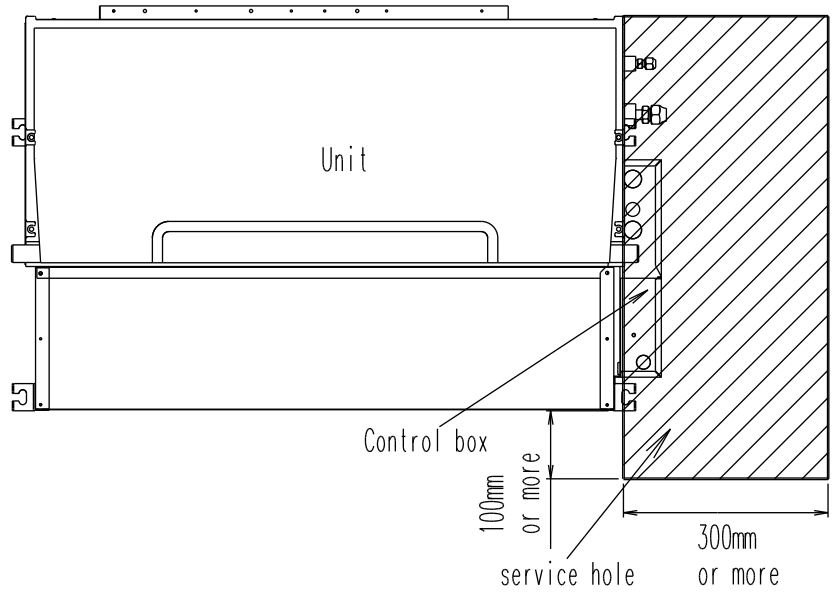

■ MOUNTING POSITION *1

Strong and durable ceiling

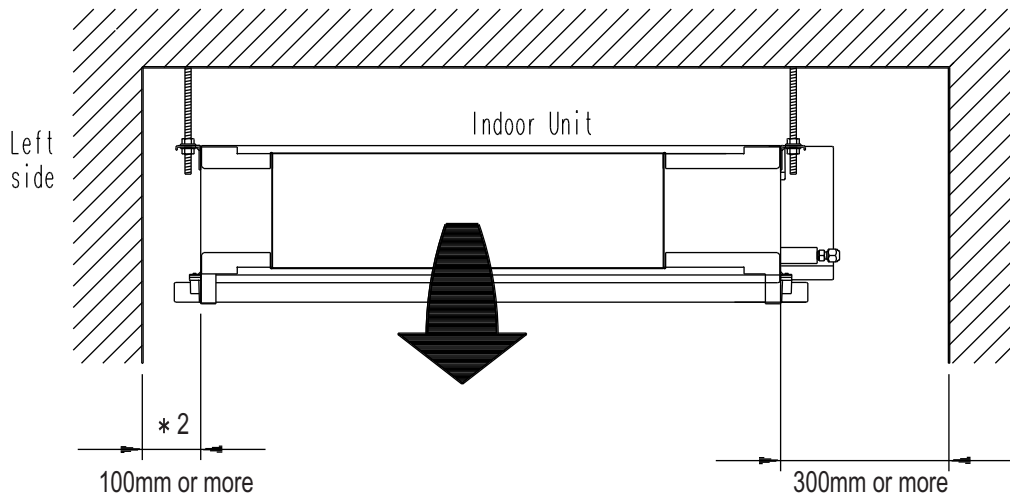

*1 When drain pump is used, leave the space required for service and maintenance (Refer to 5-6-6. DRAIN PUMP UNIT)

*2 When drain hose is connected, the required dimension is 150mm or more.

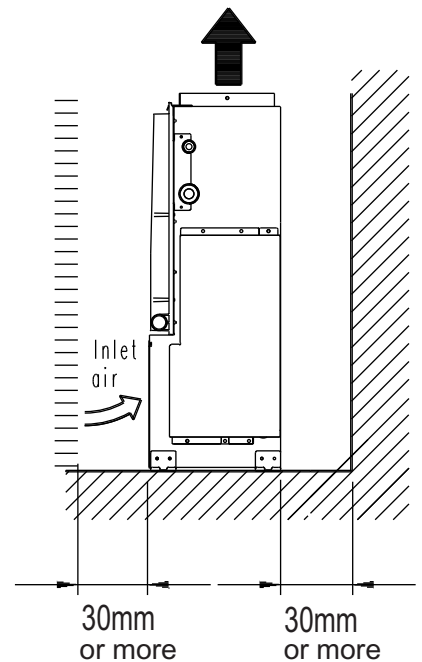
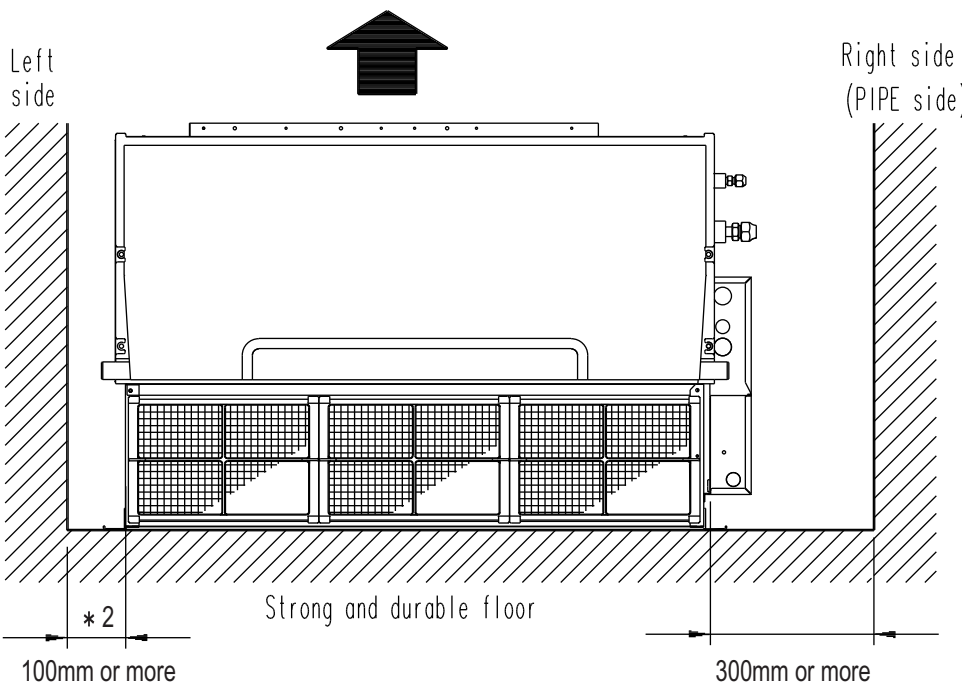

4-5-2. LOW STATIC PRESSURE DUCT TYPE

■ MODELS: ARXB25, ARXB30

4-5-3. DUCT TYPE

■ MODELS: AR25, AR30, AR36, AR45

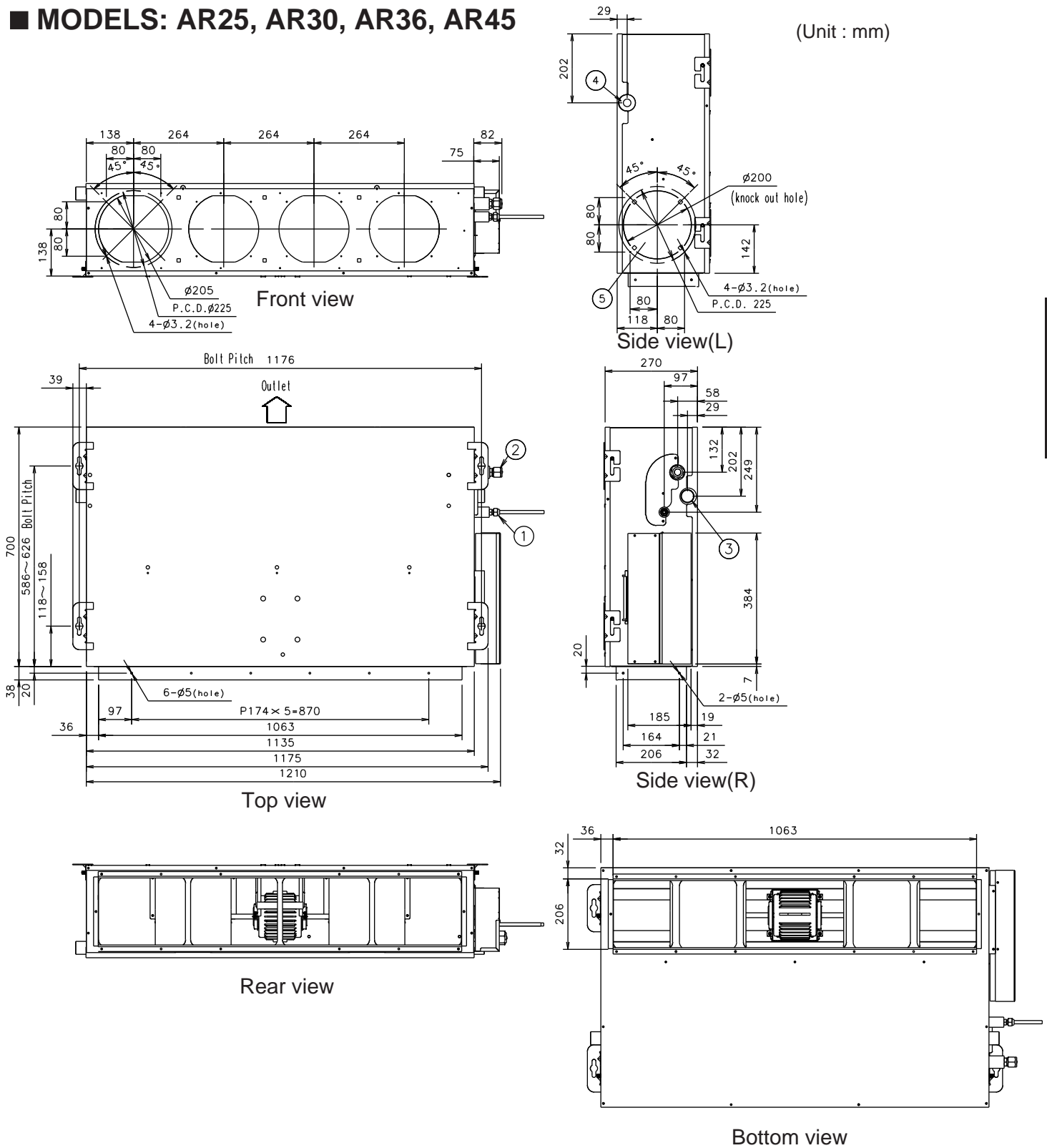

INDOOR UNIT

INDOOR UNIT

			AR25	AR30	AR36, AR45
①	Refrigerant pipe flare connection	Liquid	$\phi 6.35\text{mm}$	$\phi 9.52\text{mm}$	$\phi 9.52\text{mm}$
②		Gas	$\phi 15.88\text{mm}$	$\phi 15.88\text{mm}$	$\phi 19.05\text{mm}$
③	Drain pipe connection	Drain pipe	I.D. 35.7mm , O.D. 38.1mm		
④		Drain pipe with cap			
⑤	Knock out hole for fresh air	-	-		

■ MAINTENANCE HOLE

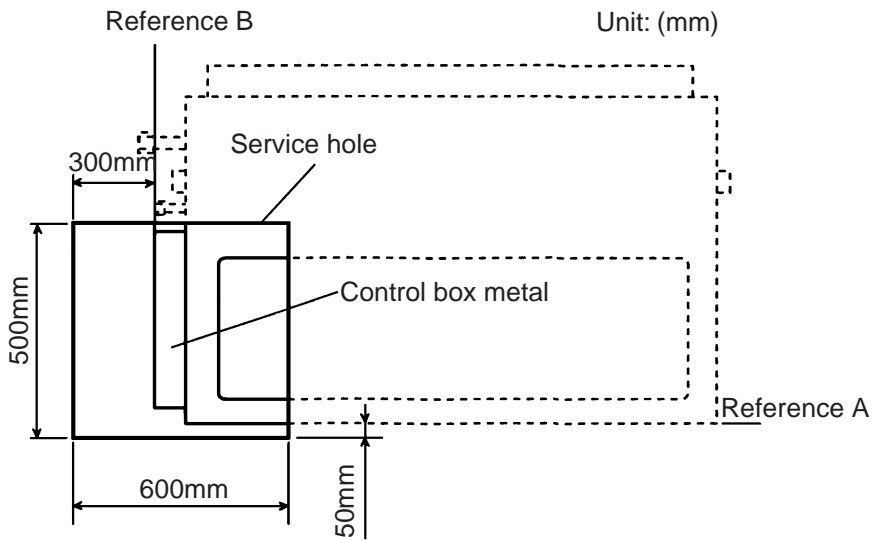

- Vertical dimension
500 mm from 50 mm below reference A
- Horizontal dimension
600 mm from 300 mm from the left from reference B

INDOOR
UNIT

INDOOR
UNIT

■ MOUNTING POSITION

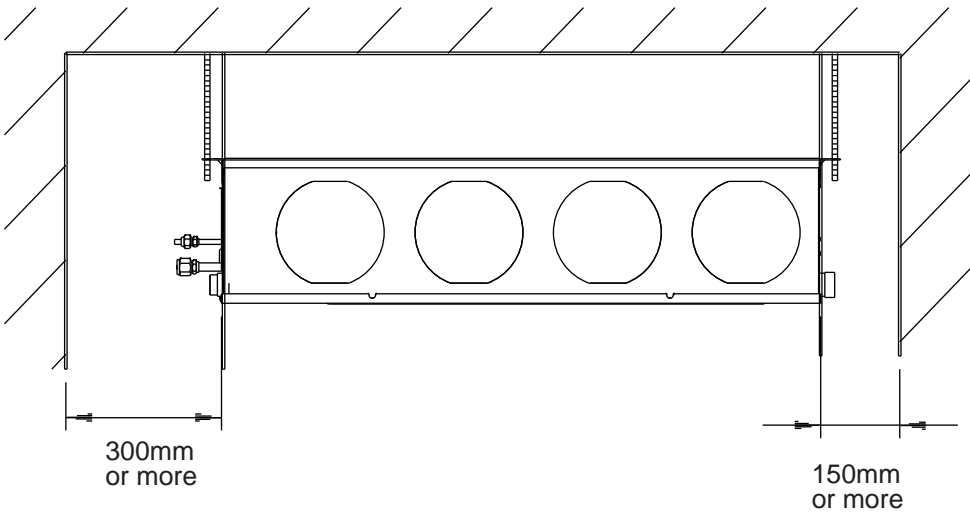

■ WHEN USING A SQUARE DUCT

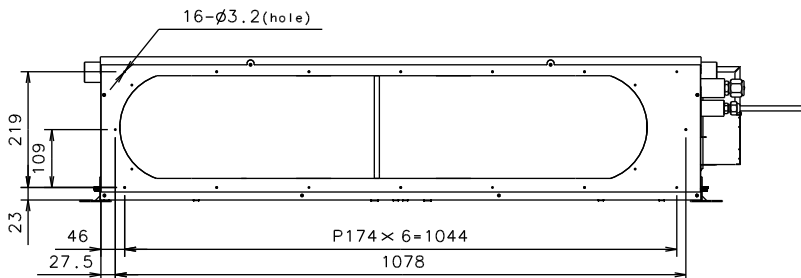

4-5-4. COMPACT CASSETTE TYPE

■ MODELS : AU7, AU9, AU12, AU14, AU18

(Unit : mm)

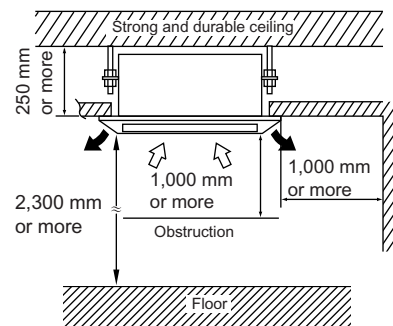
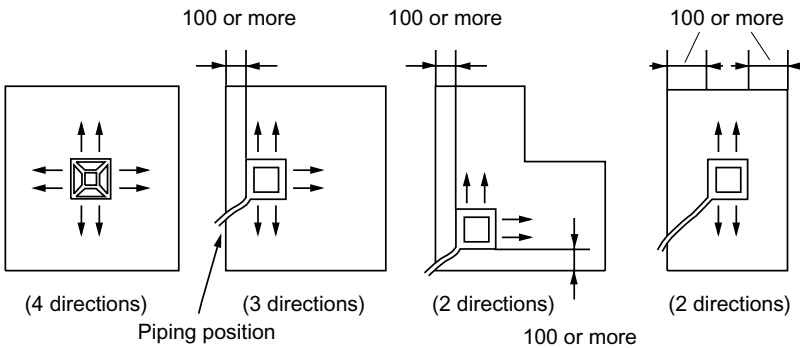
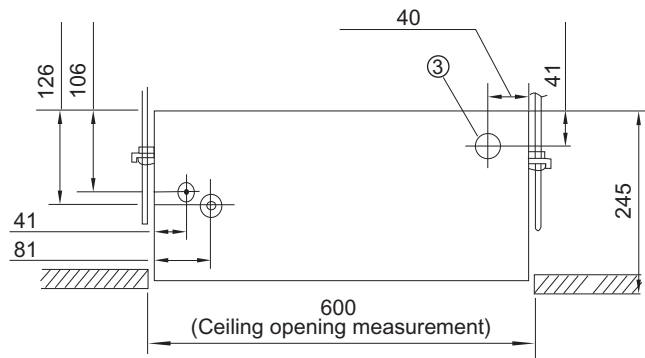
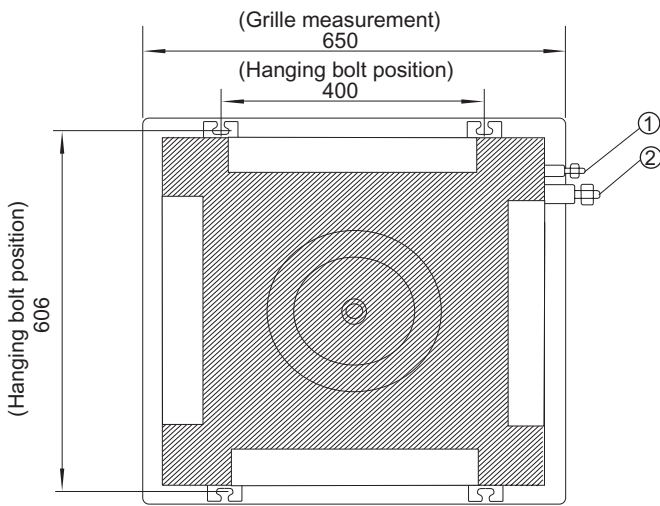
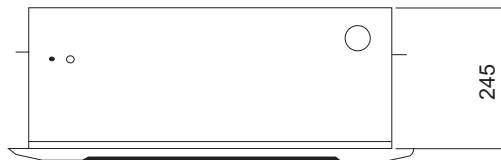
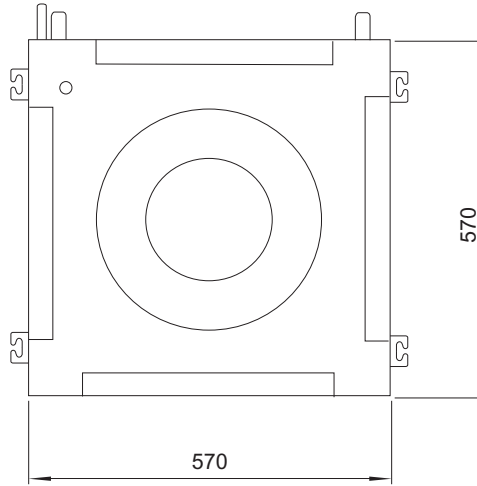
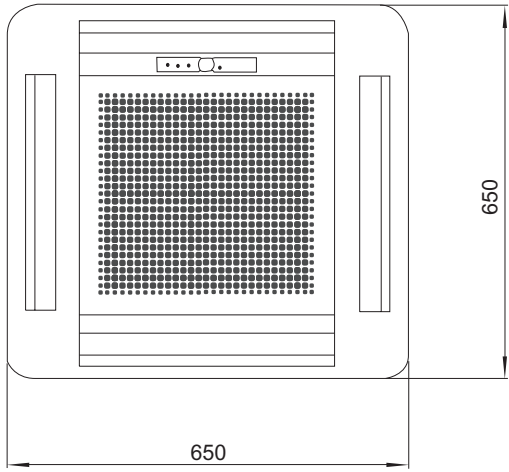

			AU7, AU9	AU12, AU14	AU18
①	Refrigerant pipe flare connection	Liquid	Ø 6.35mm	Ø 6.35mm	Ø 6.35mm
②		Gas	Ø 9.52mm	Ø 12.70mm	Ø 15.88mm
③	Drain pipe connection	Drain pipe	I.D. 32mm ; O.D. 37mm		

4-5-5. CASSETTE TYPE

■ MODELS : AU20, AU25, AU30

(Unit : mm)

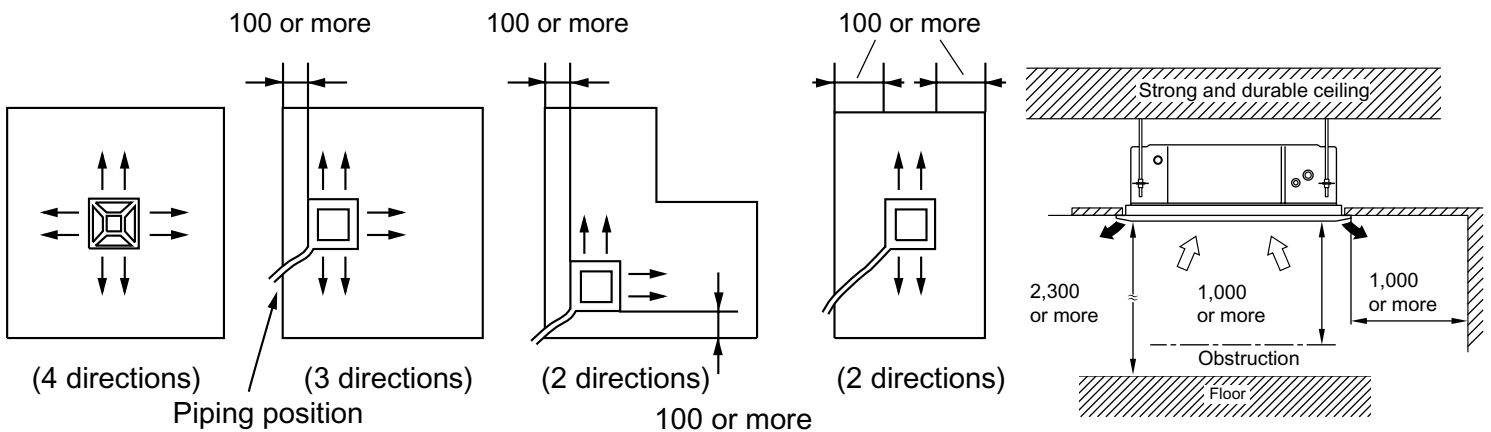
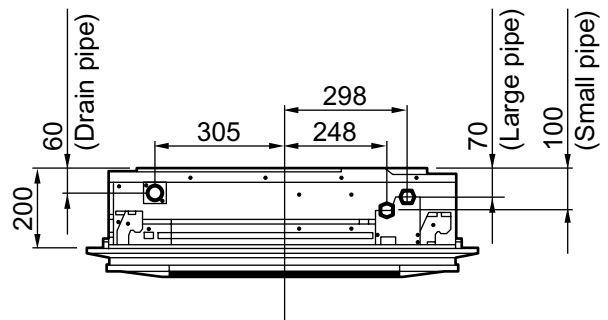
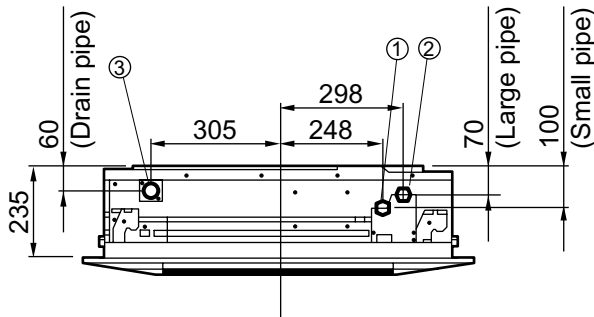
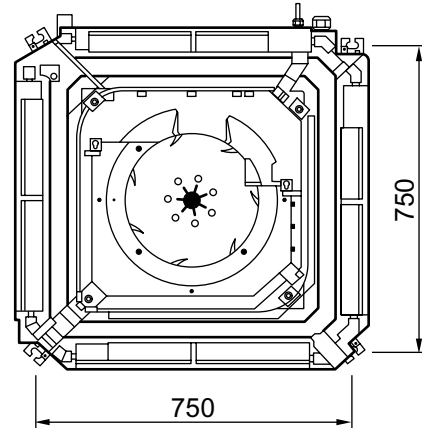
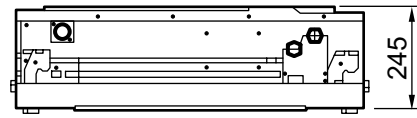
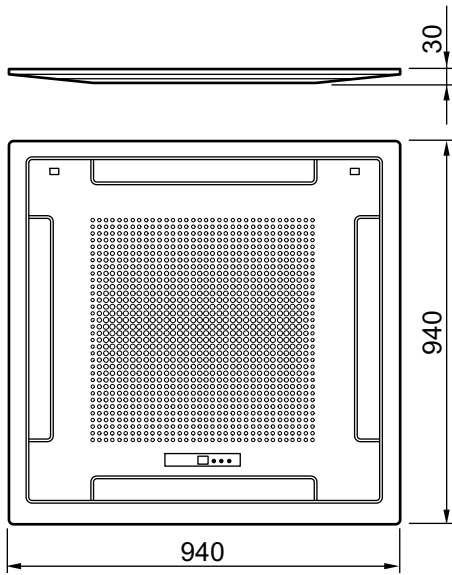

		AU20, AU25	AU30
①	Refrigerant pipe flare connection	Liquid	Ø 6.35mm
②		Gas	Ø 15.88mm
③	Drain pipe connection	I.D. 32mm ; O.D. 37mm	

MODELS : AU36, AU45, AU54

(Unit : mm)

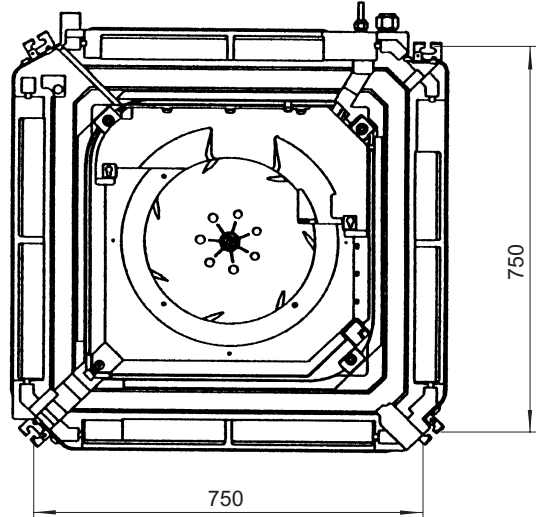
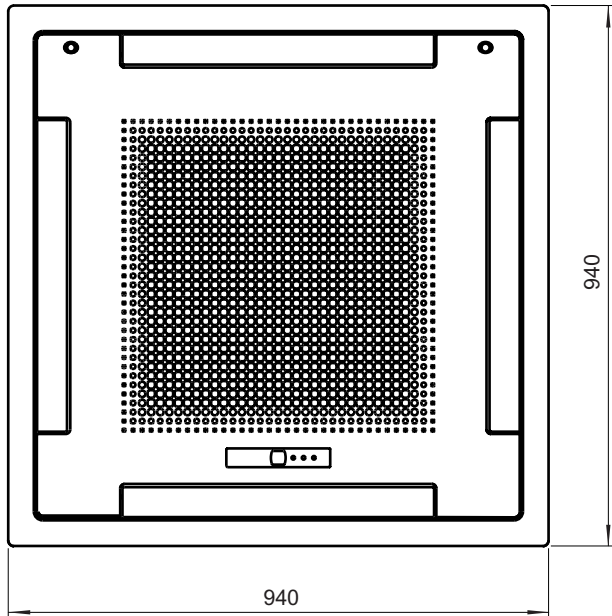
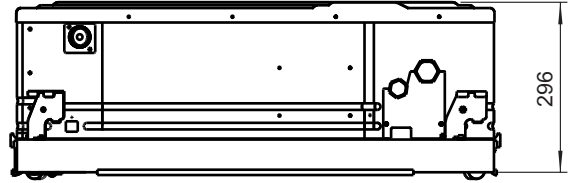

INDOOR UNIT

INDOOR UNIT

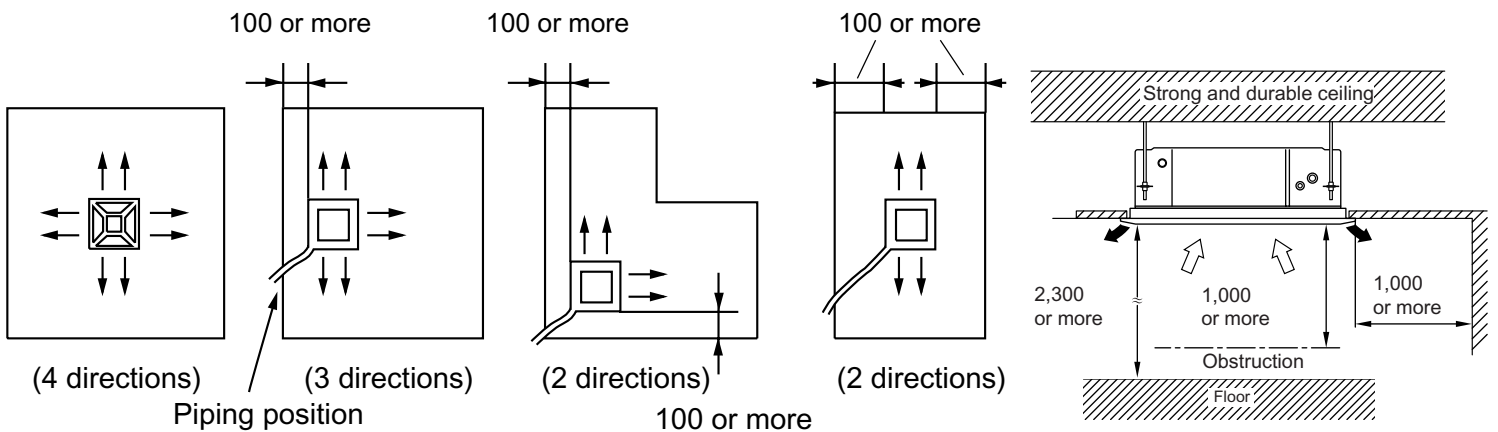
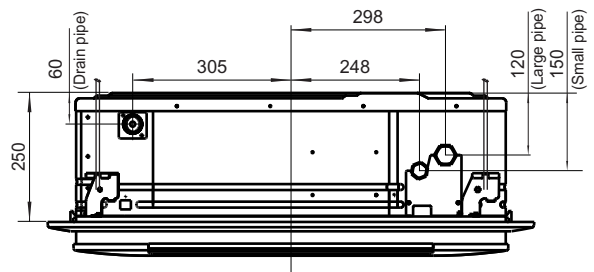
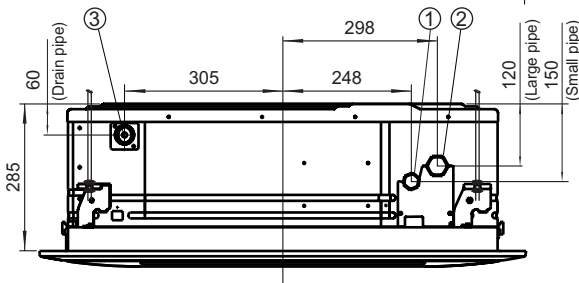

			AU36, AU45, AU54
①	Refrigerant pipe flare connection	Liquid	Ø 9.52mm
②		Gas	Ø 19.05mm
③	Drain pipe connection	Drain pipe	I.D. 32mm ; O.D. 37mm

4-5-6. COMPACT WALL MOUNTED TYPE

■ MODELS : AS7,AS9,AS12,AS14

(Unit : mm)

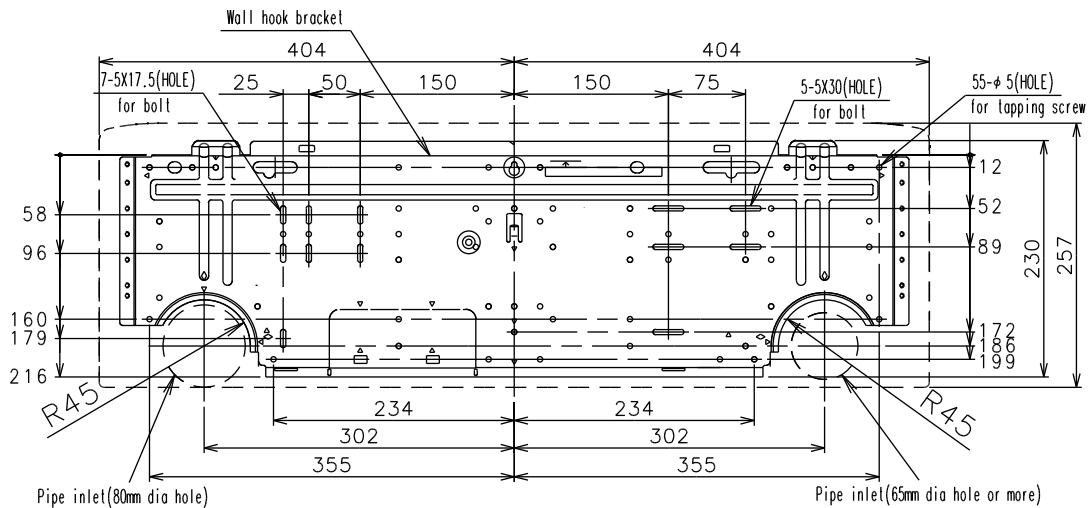
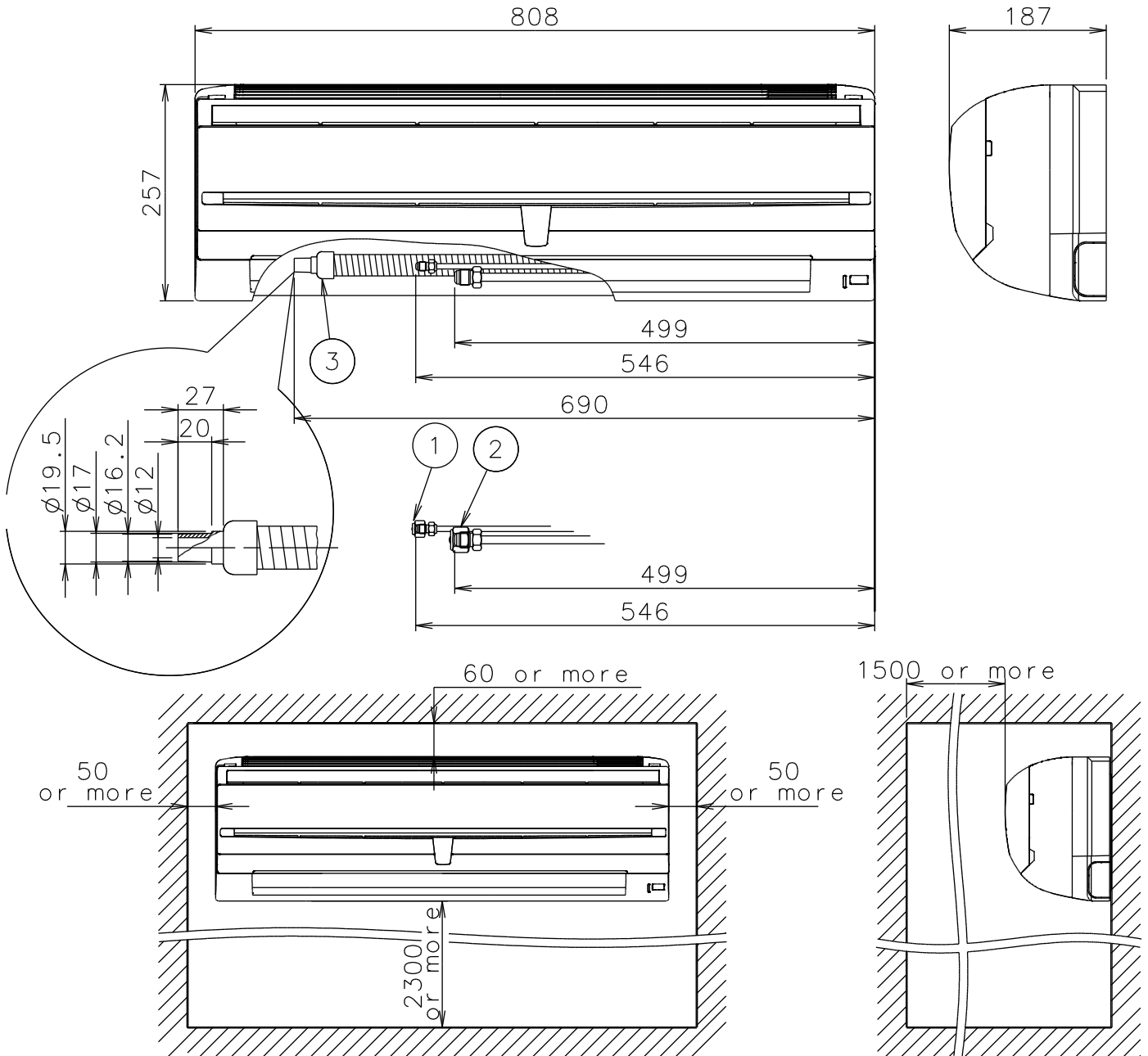

			AS7, AS9	AS12, AS14
①	Refrigerant pipe flare connection	Liquid	Ø 6.35mm	Ø 6.35mm
②		Gas	Ø 9.52mm	Ø 12.70mm
③	Drain pipe connection	Drain pipe	I.D. 12mm ; O.D. 16.2-17mm L=620mm	

4-5-7. WALL MOUNTED TYPE

■ MODELS : AS18, AS24, AS30

(Unit : mm)

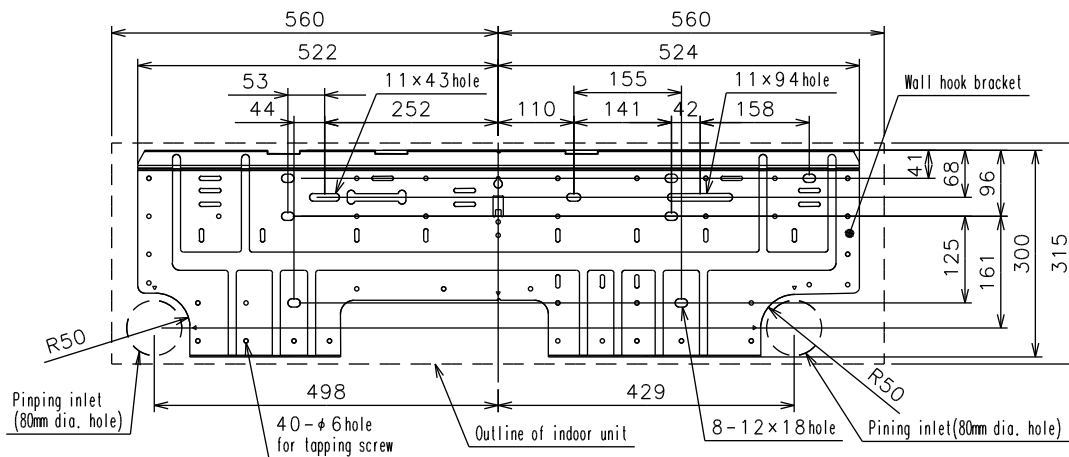
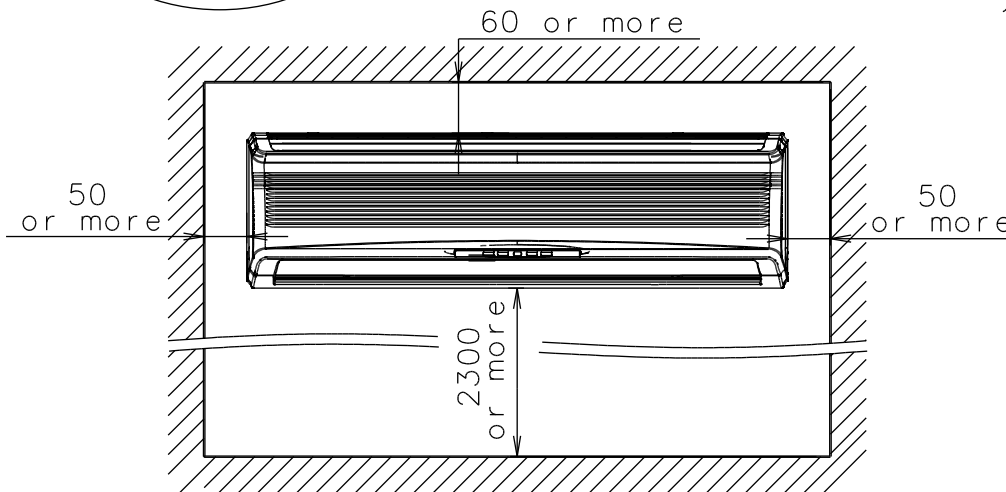
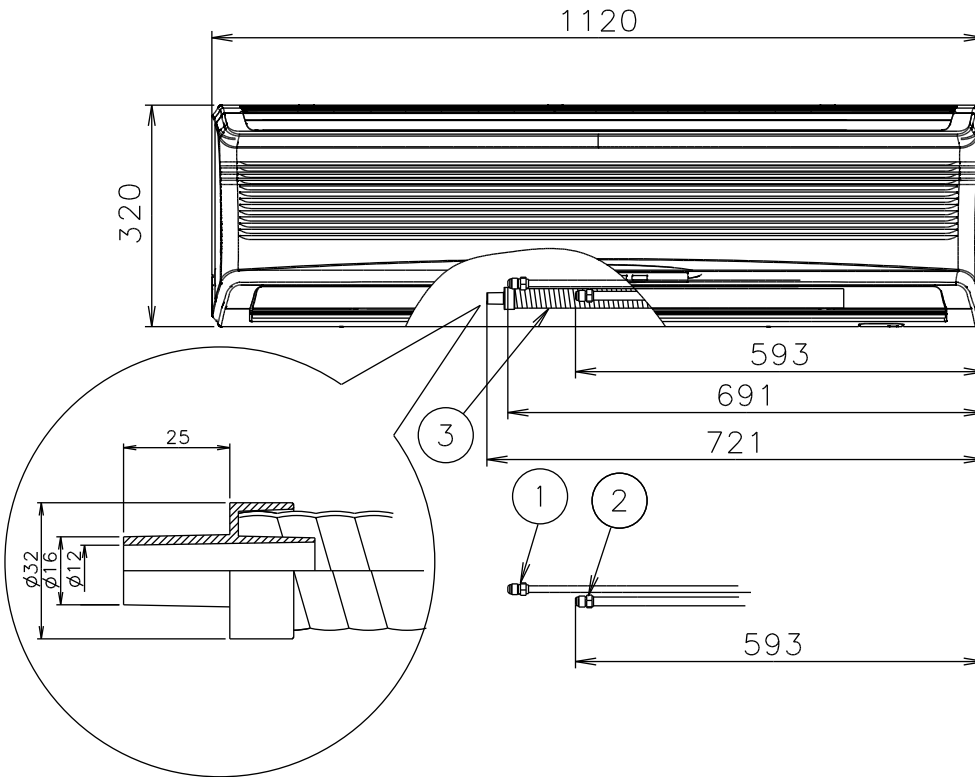

		AS18, AS24		AS30
①	Refrigerant pipe flare connection	Liquid	Ø 6.35mm	Ø 9.52mm
②		Gas	Ø 15.88mm	Ø 15.88mm
③	Drain pipe connection	Drain pipe	I.D. 12mm ; O.D. 16mm	L=670mm

MODEL : AR18

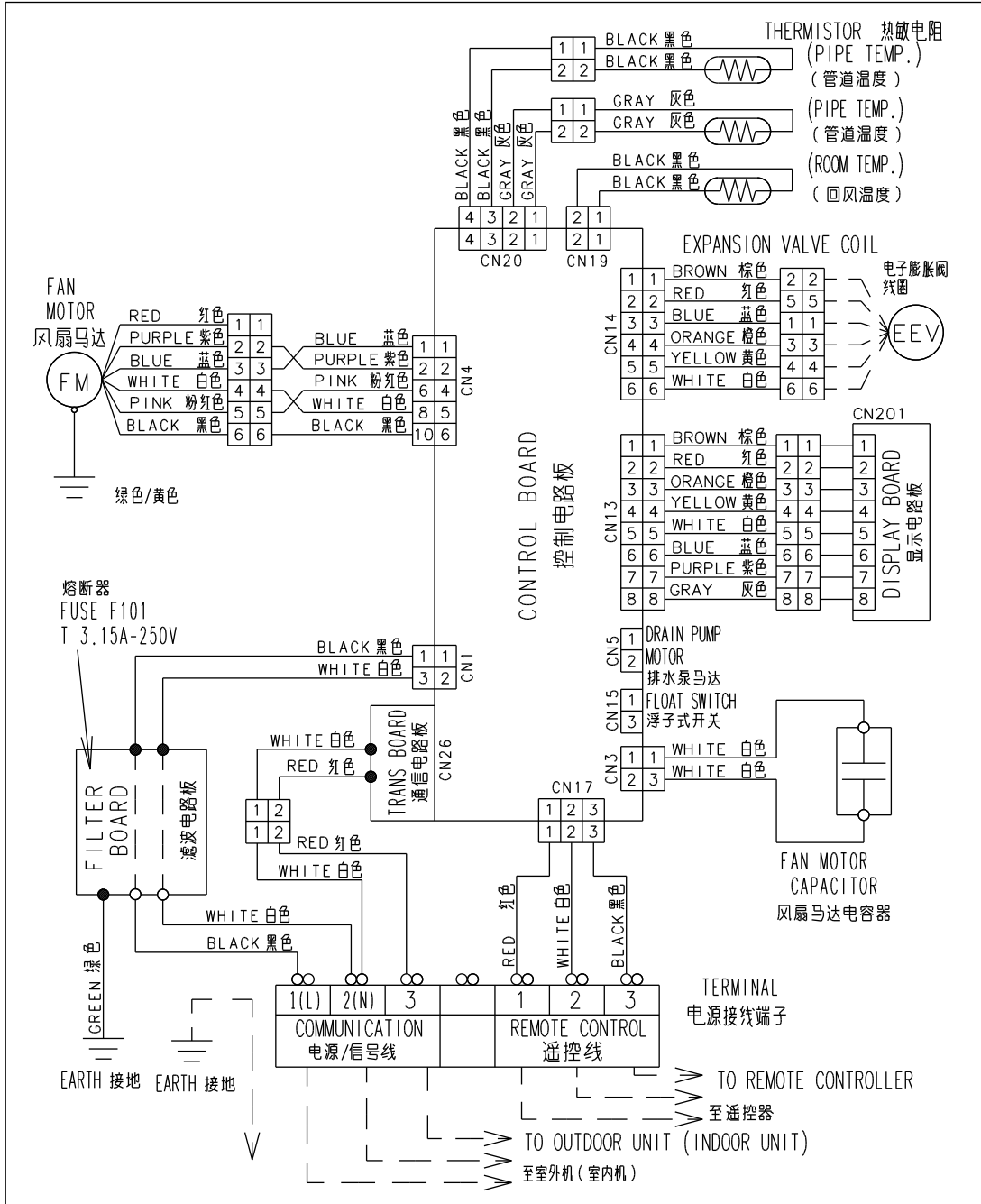

MODEL : AR22

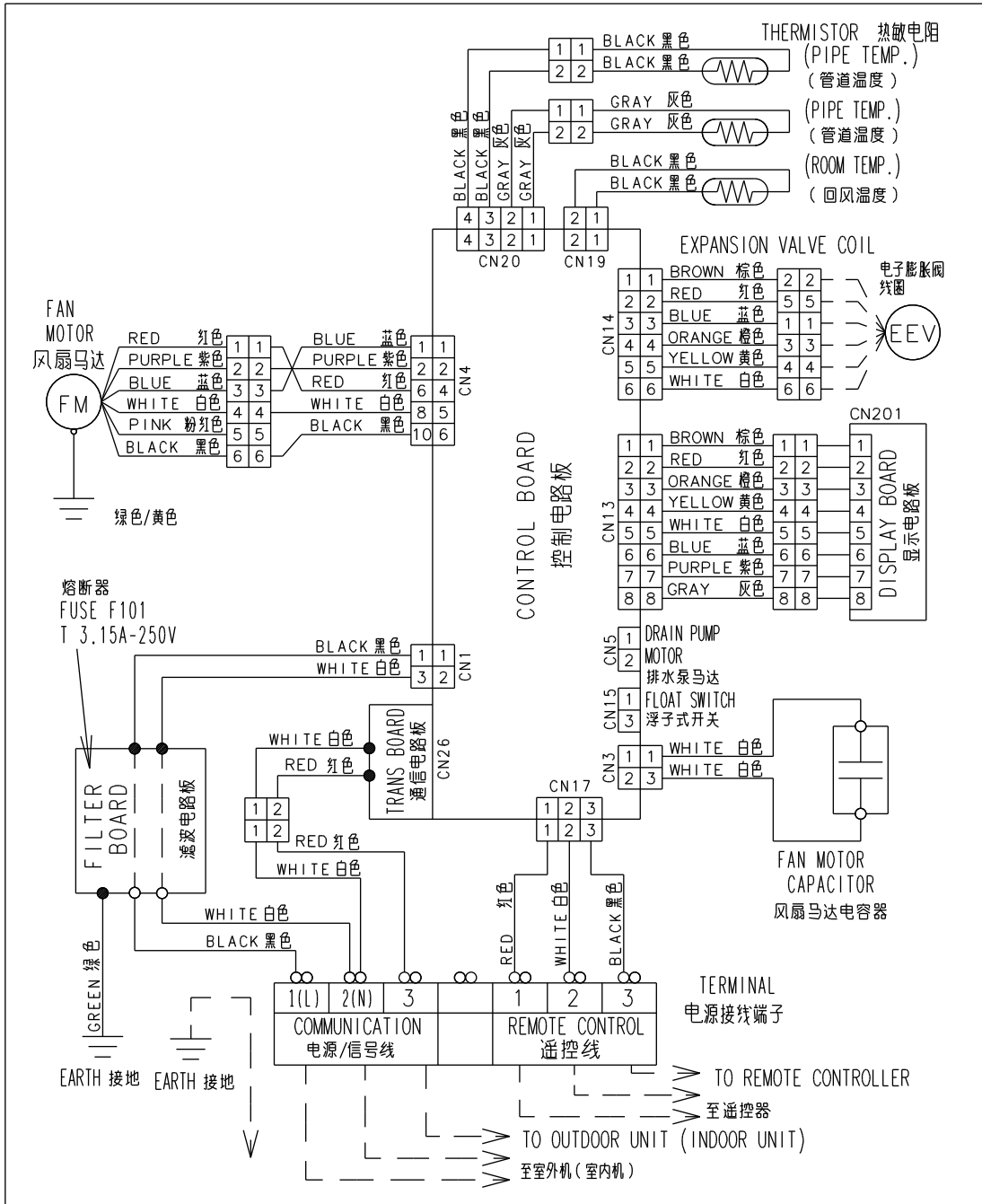

4-6-2. LOW STATIC PRESSURE DUCT TYPE

■ MODELS : ARXB25, ARXB30

4-6-3. DUCT TYPE

■ MODELS : AR25, AR30

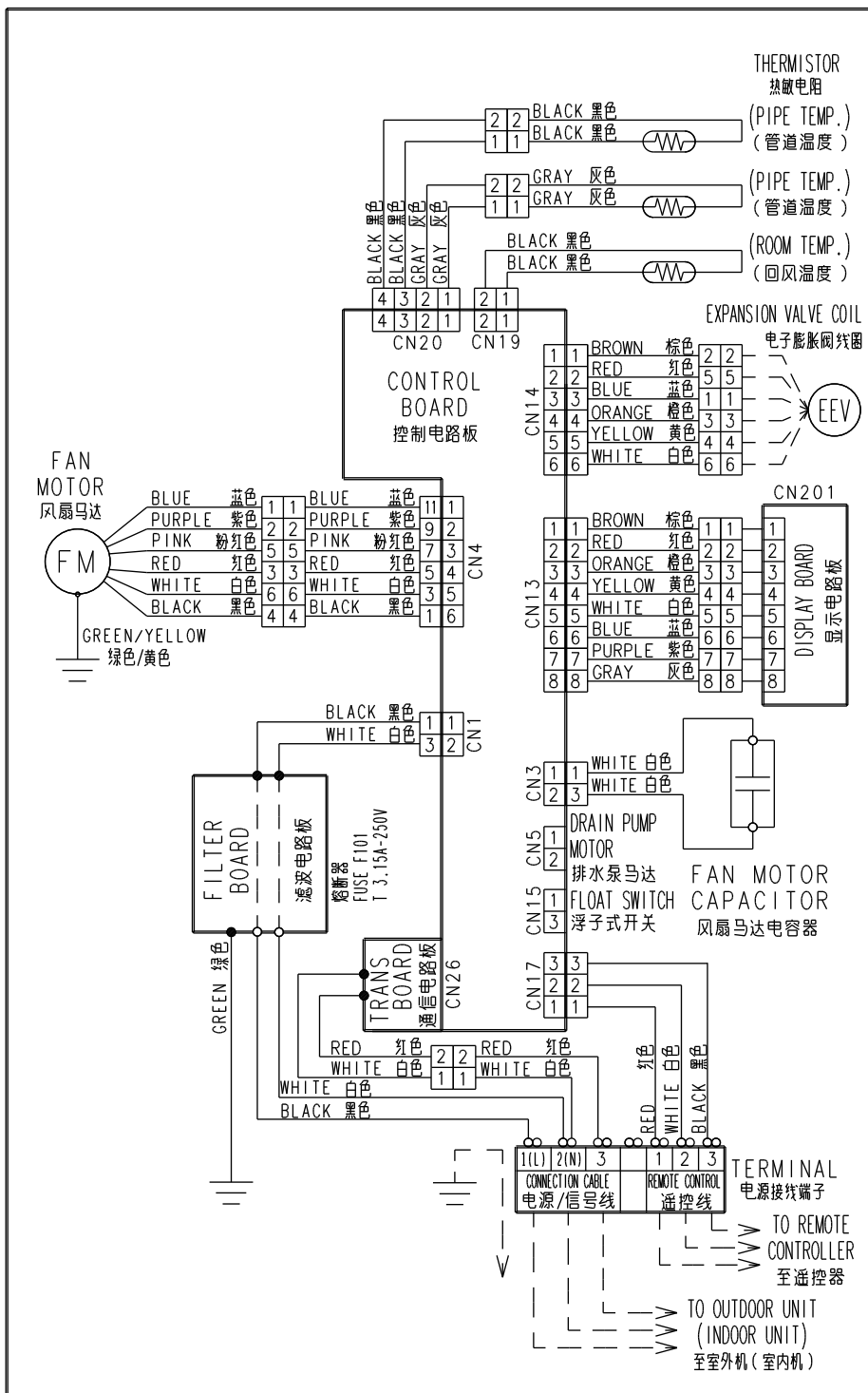

4-6-3. DUCT TYPE

■ MODELS : AR36, AR45

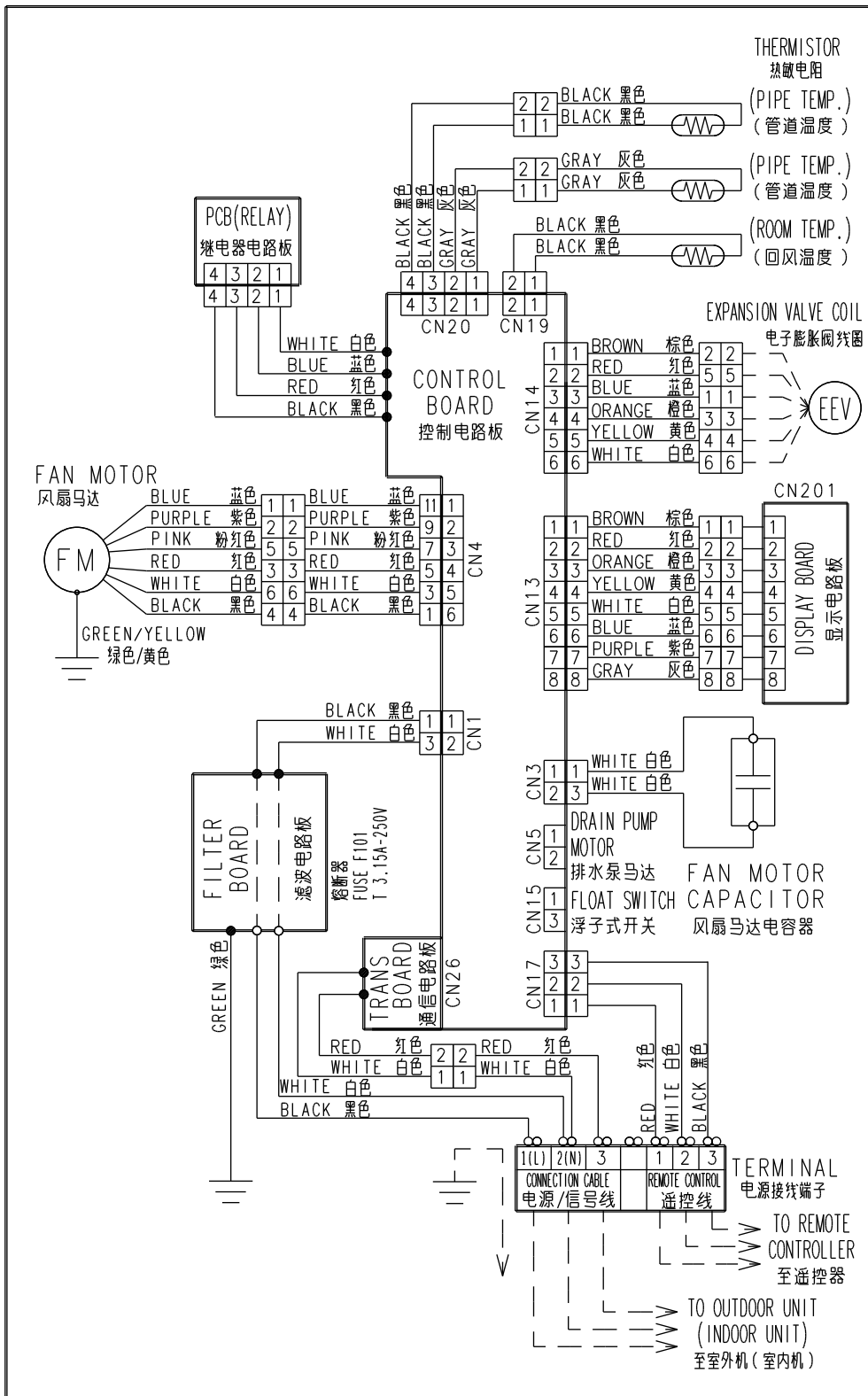

4-6-4. COMPACT CASSETTE TYPE

MODELS : AU7, AU9, AU12, AU14, AU18

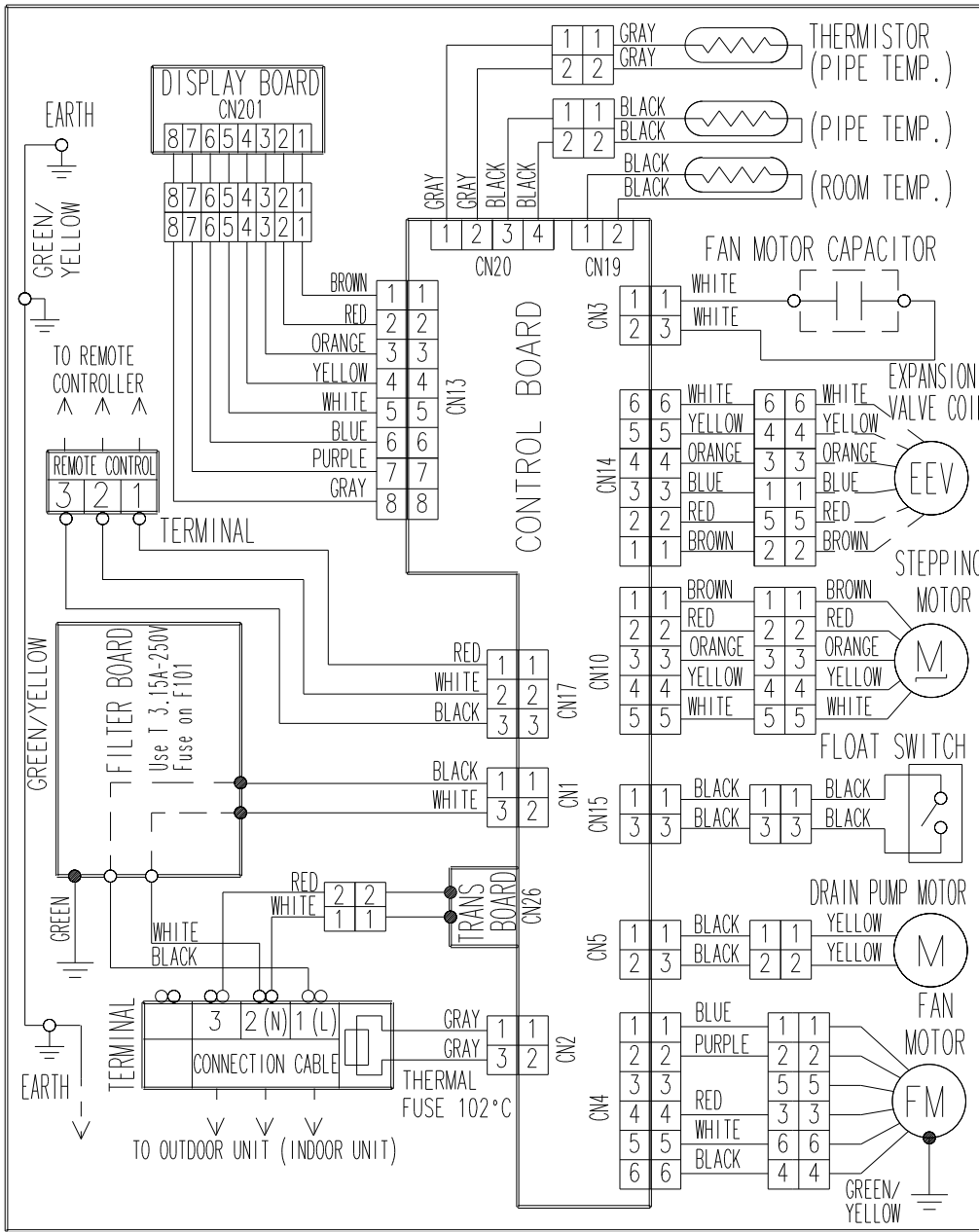

4-6-5. CASSETTE TYPE

MODELS : AU20, AU25, AU30

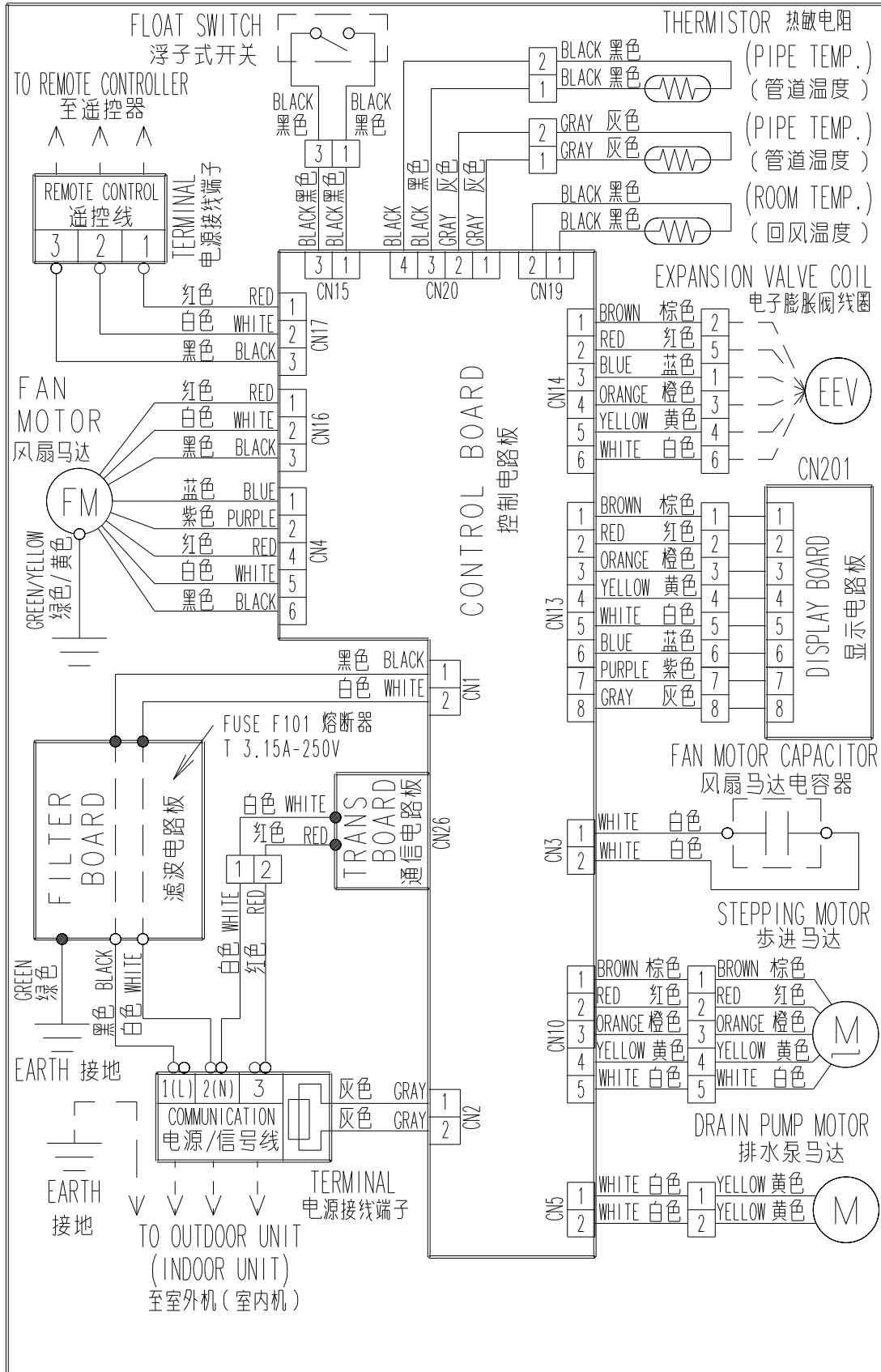

MODELS : AU36, AU45, AU54

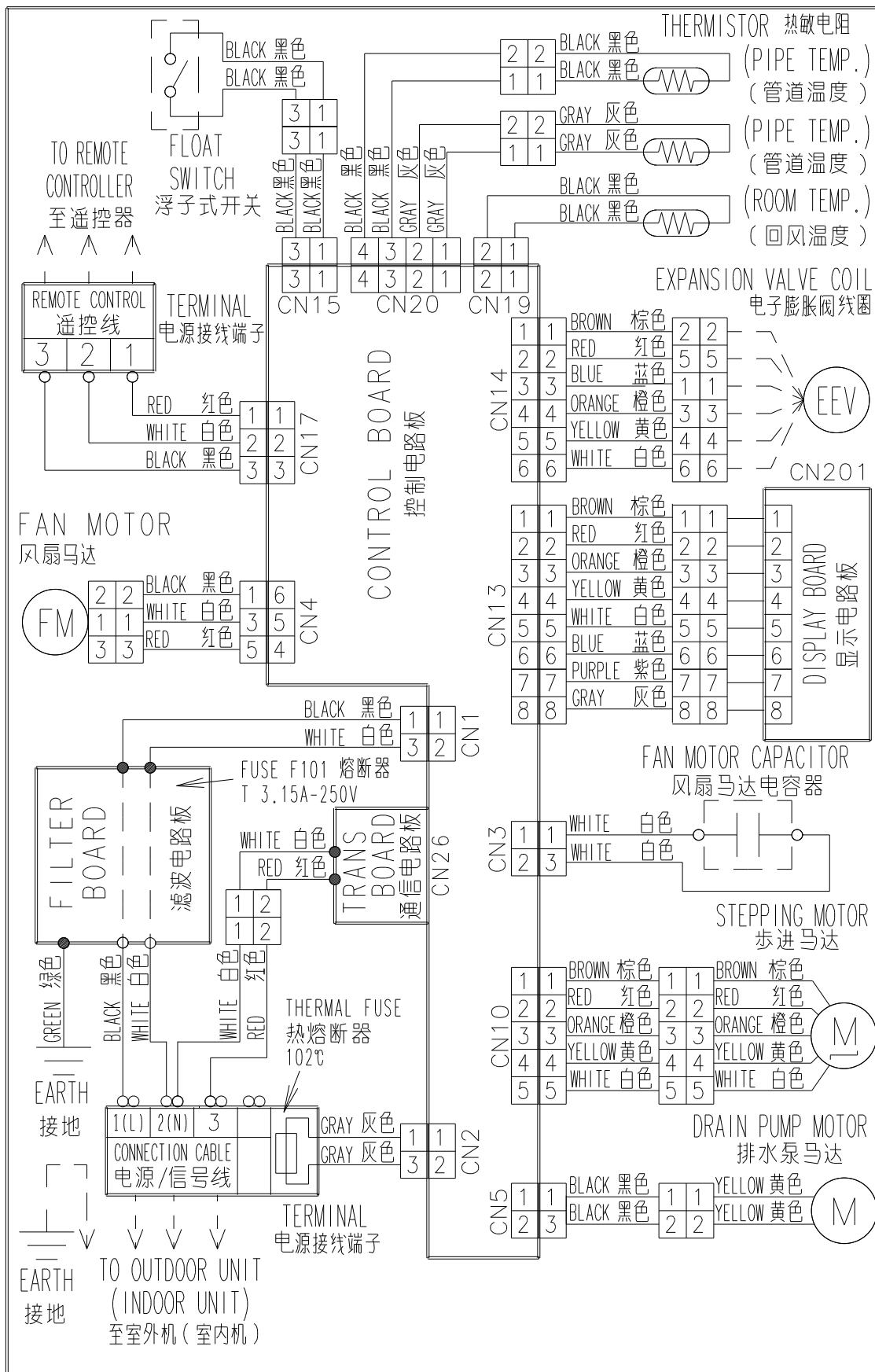

4-6-6. COMPACT WALL MOUNTED TYPE

MODELS : AS7, AS9, AS12, AS14

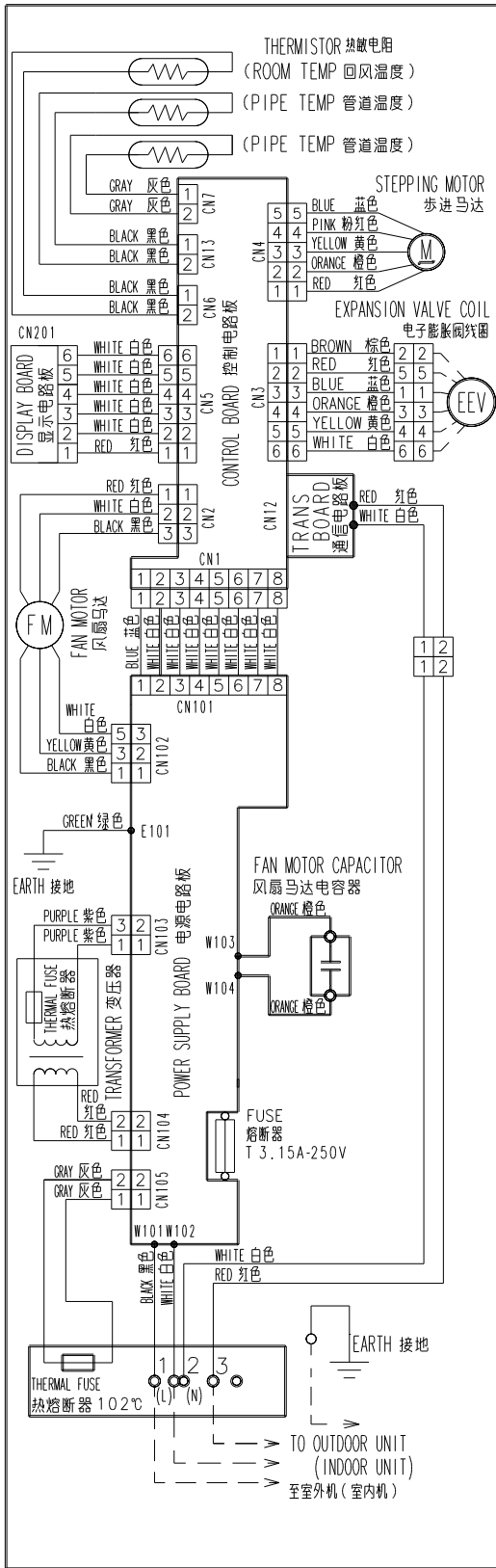

4-6-7. WALL MOUNTED TYPE

MODELS : AS18, AS24, AS30

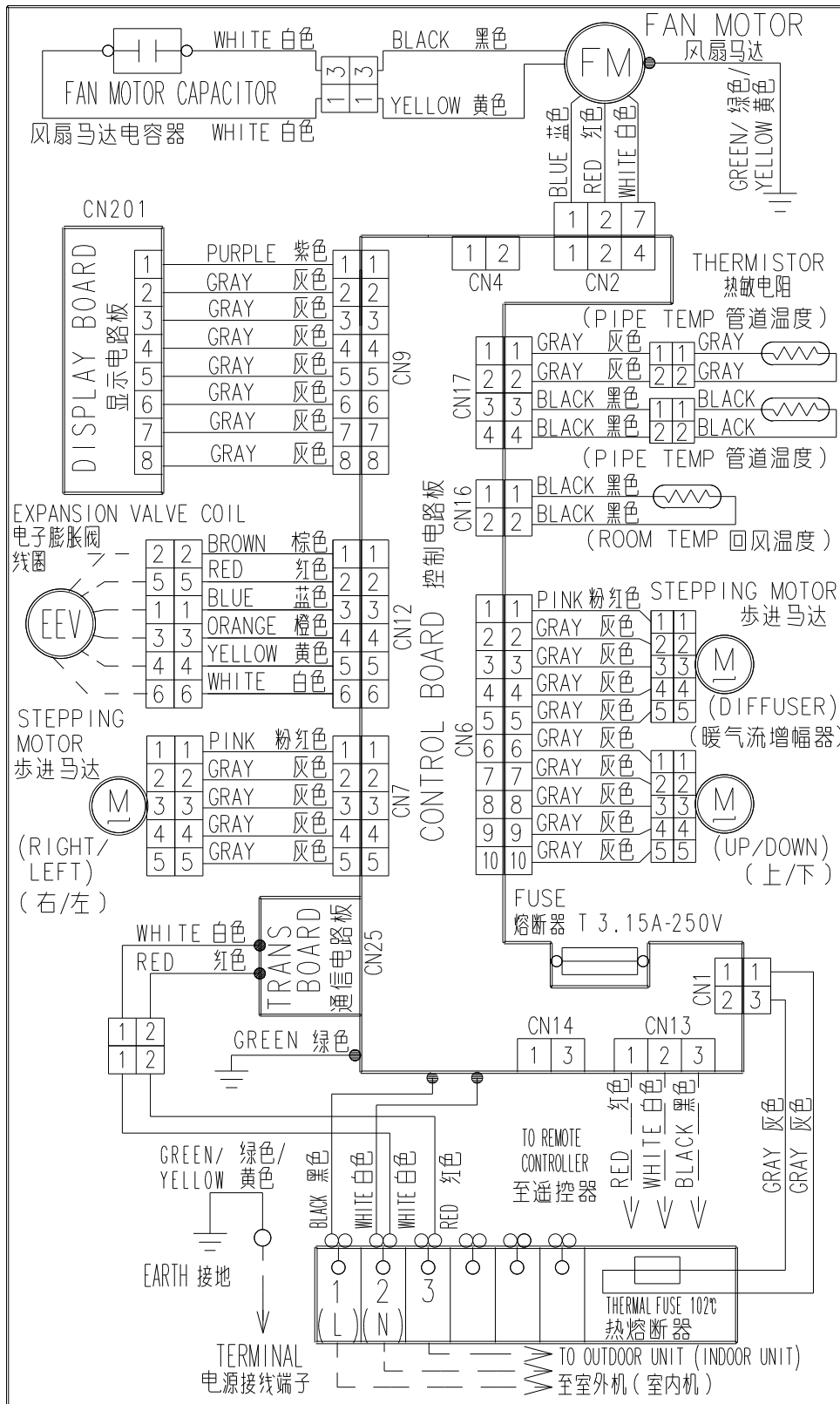





INDOOR UNIT

INDOOR UNIT

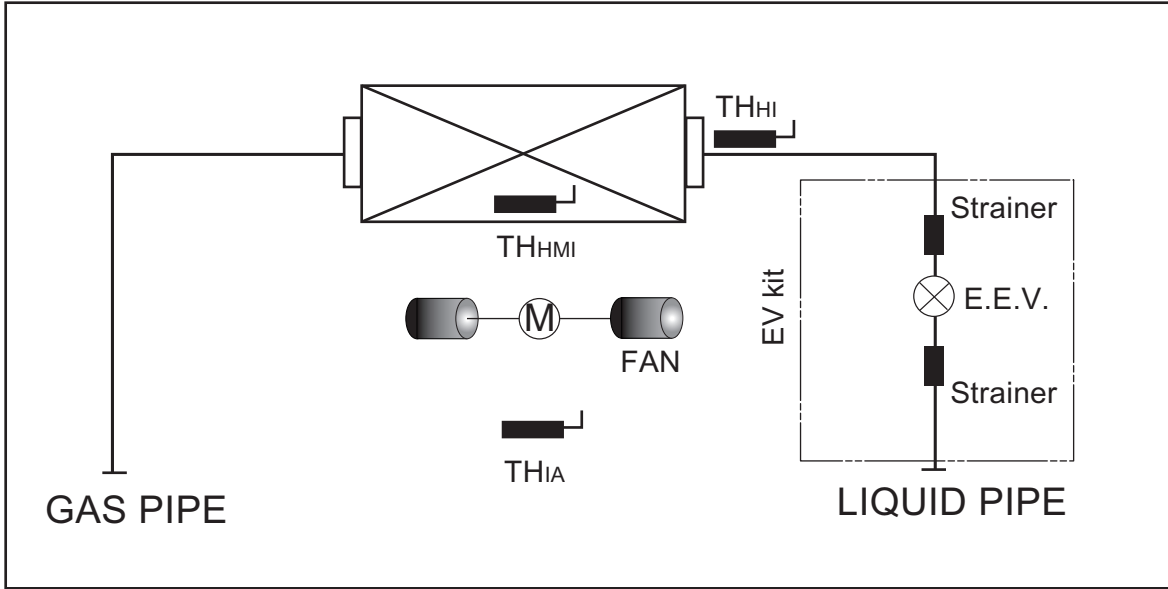
4-7. PIPING DIAGRAM

■ INDOOR UNIT



-  THiA :Indoor room temp. thermistor
-  THHi :Heat exchanger inlet thermistor
-  THHM :Heat exchanger(indoor) middle thermistor
-  E.E.V.:Electronic expansion valve

■ REFRIGERATION PIPE DIAMETER AND EV KIT TYPE

MODEL CODE	GAS PIPE Size (Thickness)	LIQUID PIPE Size (Thickness)	EV KIT TYPE
7, 9	Ø9.52 (0.8)	Ø6.35 (0.8)	UTR - EV2A*L
12, 14	Ø12.70 (0.8)	Ø6.35 (0.8)	
18, 20, 22, 24, 25	Ø15.88 (1.0)	Ø6.35 (0.8)	
30	Ø15.88 (1.0)	Ø9.52 (0.8)	UTR - EV3*L
36, 45, 54	Ø19.05 (1.2)	Ø9.52 (0.8)	

4-8. CAPACITY TABLE (COOLING)

COOLING CAPACITY

4-8-1. COMPACT DUCT TYPE (1/2)

MODEL : AR7

Outdoor Temperature		Indoor Temperature													
		20°CDB/15°CWB		23°CDB/16°CWB		26°CDB/18°CWB		27°CDB/19°CWB		28°CDB/20°CWB		30°CDB/22°CWB		32°CDB/23°CWB	
		68°FDB/59°FWB		73°FDB/61°FWB		79°FDB/64°FWB		81°FDB/66°FWB		82°FDB/68°FWB		86°FDB/72°FWB		90°FDB/73°FWB	
(°CDB)	(°FDB)	TC	SHC	TC	SHC	TC	SHC	TC	SHC	TC	SHC	TC	SHC	TC	SHC
10	50	1.55	1.18	1.70	1.43	2.00	1.60	2.15	1.63	2.30	1.63	2.62	1.70	2.75	1.82
15	59	1.55	1.18	1.70	1.43	2.00	1.60	2.15	1.63	2.30	1.63	2.62	1.70	2.75	1.82
21	70	1.55	1.18	1.70	1.43	2.00	1.60	2.15	1.63	2.30	1.63	2.58	1.68	2.62	1.76
23	73	1.55	1.18	1.70	1.43	2.00	1.60	2.15	1.63	2.30	1.63	2.54	1.67	2.60	1.74
25	77	1.55	1.18	1.70	1.43	2.00	1.60	2.15	1.63	2.30	1.63	2.49	1.65	2.56	1.74
27	81	1.55	1.18	1.70	1.43	2.00	1.60	2.15	1.63	2.30	1.63	2.45	1.64	2.52	1.74
30	86	1.55	1.18	1.70	1.43	2.00	1.60	2.15	1.63	2.30	1.63	2.41	1.61	2.45	1.69
33	91	1.55	1.18	1.70	1.43	2.00	1.60	2.15	1.63	2.24	1.63	2.34	1.59	2.39	1.67
35	95	1.55	1.18	1.70	1.43	2.00	1.60	2.15	1.63	2.19	1.60	2.30	1.59	2.34	1.66
37	99	1.55	1.18	1.70	1.43	2.00	1.60	2.11	1.60	2.15	1.59	2.26	1.56	2.30	1.66
40	104	1.55	1.18	1.70	1.43	2.00	1.60	2.04	1.57	2.09	1.56	2.17	1.54	2.21	1.62
43	109	1.55	1.18	1.70	1.43	1.91	1.57	1.96	1.55	2.00	1.54	2.09	1.50	2.13	1.60

MODEL : AR9

Outdoor Temperature		Indoor Temperature													
		20°CDB/15°CWB		23°CDB/16°CWB		26°CDB/18°CWB		27°CDB/19°CWB		28°CDB/20°CWB		30°CDB/22°CWB		32°CDB/23°CWB	
		68°FDB/59°FWB		73°FDB/61°FWB		79°FDB/64°FWB		81°FDB/66°FWB		82°FDB/68°FWB		86°FDB/72°FWB		90°FDB/73°FWB	
(°CDB)	(°FDB)	TC	SHC	TC	SHC	TC	SHC	TC	SHC	TC	SHC	TC	SHC	TC	SHC
10	50	2.02	1.51	2.21	1.84	2.60	2.06	2.80	2.10	3.00	2.13	3.42	2.19	3.58	2.33
15	59	2.02	1.51	2.21	1.84	2.60	2.06	2.80	2.10	3.00	2.13	3.42	2.19	3.58	2.33
21	70	2.02	1.51	2.21	1.84	2.60	2.06	2.80	2.10	3.00	2.13	3.36	2.18	3.42	2.29
23	73	2.02	1.51	2.21	1.84	2.60	2.06	2.80	2.10	3.00	2.13	3.30	2.15	3.39	2.27
25	77	2.02	1.51	2.21	1.84	2.60	2.06	2.80	2.10	3.00	2.13	3.25	2.14	3.33	2.23
27	81	2.02	1.51	2.21	1.84	2.60	2.06	2.80	2.10	3.00	2.13	3.19	2.11	3.28	2.23
30	86	2.02	1.51	2.21	1.84	2.60	2.06	2.80	2.10	3.00	2.13	3.14	2.10	3.19	2.20
33	91	2.02	1.51	2.21	1.84	2.60	2.06	2.80	2.10	2.91	2.10	3.05	2.04	3.11	2.18
35	95	2.02	1.51	2.21	1.84	2.60	2.06	2.80	2.10	2.86	2.08	3.00	2.04	3.05	2.14
37	99	2.02	1.51	2.21	1.84	2.60	2.06	2.74	2.09	2.80	2.04	2.94	2.03	3.00	2.13
40	104	2.02	1.51	2.21	1.84	2.60	2.06	2.66	2.05	2.72	2.01	2.83	1.98	2.88	2.08
43	109	2.02	1.51	2.21	1.84	2.49	2.02	2.55	1.99	2.60	1.98	2.72	1.93	2.77	2.05

MODEL : AR12

Outdoor Temperature		Indoor Temperature													
		20°CDB/15°CWB		23°CDB/16°CWB		26°CDB/18°CWB		27°CDB/19°CWB		28°CDB/20°CWB		30°CDB/22°CWB		32°CDB/23°CWB	
		68°FDB/59°FWB		73°FDB/61°FWB		79°FDB/64°FWB		81°FDB/66°FWB		82°FDB/68°FWB		86°FDB/72°FWB		90°FDB/73°FWB	
(°CDB)	(°FDB)	TC	SHC	TC	SHC	TC	SHC	TC	SHC	TC	SHC	TC	SHC	TC	SHC
10	50	2.52	1.86	2.77	2.27	3.26	2.54	3.50	2.59	3.75	2.62	4.27	2.69	4.48	2.87
15	59	2.52	1.86	2.77	2.27	3.26	2.54	3.50	2.59	3.75	2.62	4.27	2.69	4.48	2.87
21	70	2.52	1.86	2.77	2.27	3.26	2.54	3.50	2.59	3.75	2.62	4.20	2.69	4.27	2.78
23	73	2.52	1.86	2.77	2.27	3.26	2.54	3.50	2.59	3.75	2.62	4.13	2.64	4.24	2.80
25	77	2.52	1.86	2.77	2.27	3.26	2.54	3.50	2.59	3.75	2.62	4.06	2.64	4.17	2.75
27	81	2.52	1.86	2.77	2.27	3.26	2.54	3.50	2.59	3.75	2.62	3.99	2.59	4.10	2.74
30	86	2.52	1.86	2.77	2.27	3.26	2.54	3.50	2.59	3.75	2.62	3.92	2.59	3.99	2.67
33	91	2.52	1.86	2.77	2.27	3.26	2.54	3.50	2.59	3.64	2.58	3.82	2.52	3.89	2.64
35	95	2.52	1.86	2.77	2.27	3.26	2.54	3.50	2.59	3.57	2.53	3.75	2.51	3.82	2.63
37	99	2.52	1.86	2.77	2.27	3.26	2.54	3.43	2.54	3.50	2.52	3.68	2.46	3.75	2.62
40	104	2.52	1.86	2.77	2.27	3.26	2.54	3.33	2.49	3.40	2.48	3.54	2.44	3.61	2.56
43	109	2.52	1.86	2.77	2.27	3.12	2.46	3.19	2.45	3.26	2.41	3.40	2.38	3.47	2.49

TC : Total Capacity kW
 SHC : Sensible Heat Capacity kW

The data is based on the following conditions. Pipe length : 7.5m ; Height difference : 0 m ; Static pressure : 0 Pa.

4-8-1. COMPACT DUCT TYPE (2/2)

■ MODEL : AR14

Outdoor Temperature		Indoor Temperature													
		20°CDB/15°CWB		23°CDB/16°CWB		26°CDB/18°CWB		27°CDB/19°CWB		28°CDB/20°CWB		30°CDB/22°CWB		32°CDB/23°CWB	
		68°FDB/59°FWB		73°FDB/61°FWB		79°FDB/64°FWB		81°FDB/66°FWB		82°FDB/68°FWB		86°FDB/72°FWB		90°FDB/73°FWB	
(°CDB)	(°FDB)	TC	SHC	TC	SHC	TC	SHC	TC	SHC	TC	SHC	TC	SHC	TC	SHC
10	50	2.88	2.19	3.16	2.65	3.72	2.98	4.00	3.04	4.28	3.08	4.88	3.17	5.12	3.38
15	59	2.88	2.19	3.16	2.65	3.72	2.98	4.00	3.04	4.28	3.08	4.88	3.17	5.12	3.38
21	70	2.88	2.19	3.16	2.65	3.72	2.98	4.00	3.04	4.28	3.08	4.80	3.17	4.88	3.27
23	73	2.88	2.19	3.16	2.65	3.72	2.98	4.00	3.04	4.28	3.08	4.72	3.12	4.84	3.29
25	77	2.88	2.19	3.16	2.65	3.72	2.98	4.00	3.04	4.28	3.08	4.64	3.06	4.76	3.24
27	81	2.88	2.19	3.16	2.65	3.72	2.98	4.00	3.04	4.28	3.08	4.56	3.06	4.68	3.23
30	86	2.88	2.19	3.16	2.65	3.72	2.98	4.00	3.04	4.28	3.08	4.48	3.05	4.56	3.19
33	91	2.88	2.19	3.16	2.65	3.72	2.98	4.00	3.04	4.16	3.04	4.36	2.96	4.44	3.15
35	95	2.88	2.19	3.16	2.65	3.72	2.98	4.00	3.04	4.08	3.02	4.28	2.95	4.36	3.10
37	99	2.88	2.19	3.16	2.65	3.72	2.98	3.92	3.02	4.00	2.96	4.20	2.94	4.28	3.08
40	104	2.88	2.19	3.16	2.65	3.72	2.98	3.80	2.96	3.88	2.91	4.04	2.87	4.12	3.01
43	109	2.88	2.19	3.16	2.65	3.56	2.92	3.64	2.88	3.72	2.86	3.88	2.83	3.96	2.97

■ MODEL : AR18

Outdoor Temperature		Indoor Temperature													
		20°CDB/15°CWB		23°CDB/16°CWB		26°CDB/18°CWB		27°CDB/19°CWB		28°CDB/20°CWB		30°CDB/22°CWB		32°CDB/23°CWB	
		68°FDB/59°FWB		73°FDB/61°FWB		79°FDB/64°FWB		81°FDB/66°FWB		82°FDB/68°FWB		86°FDB/72°FWB		90°FDB/73°FWB	
(°CDB)	(°FDB)	TC	SHC	TC	SHC	TC	SHC	TC	SHC	TC	SHC	TC	SHC	TC	SHC
10	50	3.82	2.79	4.19	3.37	4.93	3.78	5.30	3.85	5.67	3.92	6.47	4.04	6.78	4.30
15	59	3.82	2.79	4.19	3.37	4.93	3.78	5.30	3.85	5.67	3.92	6.47	4.04	6.78	4.30
21	70	3.82	2.79	4.19	3.37	4.93	3.78	5.30	3.85	5.67	3.92	6.36	4.00	6.47	4.17
23	73	3.82	2.79	4.19	3.37	4.93	3.78	5.30	3.85	5.67	3.92	6.25	3.96	6.41	4.15
25	77	3.82	2.79	4.19	3.37	4.93	3.78	5.30	3.85	5.67	3.92	6.15	3.92	6.31	4.11
27	81	3.82	2.79	4.19	3.37	4.93	3.78	5.30	3.85	5.67	3.92	6.04	3.88	6.20	4.07
30	86	3.82	2.79	4.19	3.37	4.93	3.78	5.30	3.85	5.67	3.92	5.94	3.84	6.04	4.02
33	91	3.82	2.79	4.19	3.37	4.93	3.78	5.30	3.85	5.51	3.85	5.78	3.78	5.88	3.96
35	95	3.82	2.79	4.19	3.37	4.93	3.78	5.30	3.85	5.41	3.81	5.67	3.74	5.78	3.92
37	99	3.82	2.79	4.19	3.37	4.93	3.78	5.19	3.81	5.30	3.76	5.57	3.70	5.67	3.88
40	104	3.82	2.79	4.19	3.37	4.93	3.78	5.04	3.74	5.14	3.70	5.35	3.62	5.46	3.80
43	109	3.82	2.79	4.19	3.37	4.72	3.69	4.82	3.65	4.93	3.61	5.14	3.54	5.25	3.73

■ MODEL : AR22

Outdoor Temperature		Indoor Temperature													
		20°CDB/15°CWB		23°CDB/16°CWB		26°CDB/18°CWB		27°CDB/19°CWB		28°CDB/20°CWB		30°CDB/22°CWB		32°CDB/23°CWB	
		68°FDB/59°FWB		73°FDB/61°FWB		79°FDB/64°FWB		81°FDB/66°FWB		82°FDB/68°FWB		86°FDB/72°FWB		90°FDB/73°FWB	
(°CDB)	(°FDB)	TC	SHC	TC	SHC	TC	SHC	TC	SHC	TC	SHC	TC	SHC	TC	SHC
10	50	4.32	3.24	4.74	3.93	5.58	4.41	6.00	4.50	6.42	4.56	7.32	4.68	7.68	4.99
15	59	4.32	3.24	4.74	3.93	5.58	4.41	6.00	4.50	6.42	4.56	7.32	4.68	7.68	4.99
21	70	4.32	3.24	4.74	3.93	5.58	4.41	6.00	4.50	6.42	4.56	7.20	4.68	7.32	4.90
23	73	4.32	3.24	4.74	3.93	5.58	4.41	6.00	4.50	6.42	4.56	7.08	4.60	7.26	4.86
25	77	4.32	3.24	4.74	3.93	5.58	4.41	6.00	4.50	6.42	4.56	6.96	4.59	7.14	4.86
27	81	4.32	3.24	4.74	3.93	5.58	4.41	6.00	4.50	6.42	4.56	6.84	4.51	7.02	4.77
30	86	4.32	3.24	4.74	3.93	5.58	4.41	6.00	4.50	6.42	4.56	6.72	4.50	6.84	4.72
33	91	4.32	3.24	4.74	3.93	5.58	4.41	6.00	4.50	6.24	4.49	6.54	4.45	6.66	4.66
35	95	4.32	3.24	4.74	3.93	5.58	4.41	6.00	4.50	6.12	4.47	6.42	4.37	6.54	4.58
37	99	4.32	3.24	4.74	3.93	5.58	4.41	5.88	4.47	6.00	4.44	6.30	4.35	6.42	4.56
40	104	4.32	3.24	4.74	3.93	5.58	4.41	5.70	4.39	5.82	4.37	6.06	4.24	6.18	4.51
43	109	4.32	3.24	4.74	3.93	5.34	4.33	5.46	4.31	5.58	4.24	5.82	4.19	5.94	4.40

TC : Total Capacity kW
 SHC : Sensible Heat Capacity kW

The data is based on the following conditions. Pipe length : 7.5m ; Height difference : 0 m ; Static pressure : 0 Pa.

4-8-2. LOW STATIC PRESSURE DUCT TYPE

■ MODEL : ARXB25

Outdoor Temperature		Indoor Temperature													
		20°CDB/15°CWB		23°CDB/16°CWB		26°CDB/18°CWB		27°CDB/19°CWB		28°CDB/20°CWB		30°CDB/22°CWB		32°CDB/23°CWB	
		68°FDB/59°FWB		73°FDB/61°FWB		79°FDB/64°FWB		81°FDB/66°FWB		82°FDB/68°FWB		86°FDB/72°FWB		90°FDB/73°FWB	
(°CDB)	(°FDB)	TC	SHC	TC	SHC	TC	SHC	TC	SHC	TC	SHC	TC	SHC	TC	SHC
10	50	5.08	4.06	5.57	4.97	6.56	5.57	7.05	5.66	7.54	5.74	8.60	5.89	9.02	6.29
15	59	5.08	4.06	5.57	4.97	6.56	5.57	7.05	5.66	7.54	5.74	8.60	5.89	9.02	6.29
21	70	5.08	4.06	5.57	4.97	6.56	5.57	7.05	5.66	7.54	5.74	8.46	5.84	8.60	6.14
23	73	5.08	4.06	5.57	4.97	6.56	5.57	7.05	5.66	7.54	5.74	8.32	5.78	8.53	6.11
25	77	5.08	4.06	5.57	4.97	6.56	5.57	7.05	5.66	7.54	5.74	8.18	5.73	8.39	6.07
27	81	5.08	4.06	5.57	4.97	6.56	5.57	7.05	5.66	7.54	5.74	8.04	5.68	8.25	6.02
30	86	5.08	4.06	5.57	4.97	6.56	5.57	7.05	5.66	7.54	5.74	7.90	5.63	8.04	5.94
33	91	5.08	4.06	5.57	4.97	6.56	5.57	7.05	5.66	7.33	5.66	7.68	5.56	7.83	5.87
35	95	5.08	4.06	5.57	4.97	6.56	5.57	7.05	5.66	7.19	5.60	7.54	5.51	7.68	5.82
37	99	5.08	4.06	5.57	4.97	6.56	5.57	6.91	5.61	7.05	5.55	7.40	5.46	7.54	5.78
40	104	5.08	4.06	5.57	4.97	6.56	5.57	6.70	5.52	6.84	5.47	7.12	5.36	7.26	5.68
43	109	5.08	4.06	5.57	4.97	6.27	5.46	6.42	5.41	6.56	5.36	6.84	5.26	6.98	5.59

■ MODEL : ARXB30

Outdoor Temperature		Indoor Temperature													
		20°CDB/15°CWB		23°CDB/16°CWB		26°CDB/18°CWB		27°CDB/19°CWB		28°CDB/20°CWB		30°CDB/22°CWB		32°CDB/23°CWB	
		68°FDB/59°FWB		73°FDB/61°FWB		79°FDB/64°FWB		81°FDB/66°FWB		82°FDB/68°FWB		86°FDB/72°FWB		90°FDB/73°FWB	
(°CDB)	(°FDB)	TC	SHC	TC	SHC	TC	SHC	TC	SHC	TC	SHC	TC	SHC	TC	SHC
10	50	6.34	4.62	6.95	5.58	8.18	6.26	8.80	6.38	9.42	6.49	10.7	6.70	11.3	7.12
15	59	6.34	4.62	6.95	5.58	8.18	6.26	8.80	6.38	9.42	6.49	10.7	6.70	11.3	7.12
21	70	6.34	4.62	6.95	5.58	8.18	6.26	8.80	6.38	9.42	6.49	10.6	6.63	10.7	6.91
23	73	6.34	4.62	6.95	5.58	8.18	6.26	8.80	6.38	9.42	6.49	10.4	6.56	10.6	6.88
25	77	6.34	4.62	6.95	5.58	8.18	6.26	8.80	6.38	9.42	6.49	10.2	6.49	10.5	6.82
27	81	6.34	4.62	6.95	5.58	8.18	6.26	8.80	6.38	9.42	6.49	10.0	6.43	10.3	6.75
30	86	6.34	4.62	6.95	5.58	8.18	6.26	8.80	6.38	9.42	6.49	9.86	6.36	10.0	6.65
33	91	6.34	4.62	6.95	5.58	8.18	6.26	8.80	6.38	9.15	6.38	9.59	6.26	9.77	6.56
35	95	6.34	4.62	6.95	5.58	8.18	6.26	8.80	6.38	8.98	6.31	9.42	6.19	9.59	6.49
37	99	6.34	4.62	6.95	5.58	8.18	6.26	8.62	6.31	8.80	6.24	9.24	6.12	9.42	6.43
40	104	6.34	4.62	6.95	5.58	8.18	6.26	8.36	6.20	8.54	6.13	8.89	5.99	9.06	6.30
43	109	6.34	4.62	6.95	5.58	7.83	6.11	8.01	6.05	8.18	5.99	8.54	5.86	8.71	6.18

TC : Total Capacity kW
 SHC : Sensible Heat Capacity kW

The data is based on the following conditions. Pipe length : 7.5m ; Height difference : 0 m ; Static pressure : 0 Pa.

4-8-3. DUCT TYPE

COOLING CAPACITY

MODEL : AR25

Outdoor Temperature		Indoor Temperature													
		20°CDB/15°CWB		23°CDB/16°CWB		26°CDB/18°CWB		27°CDB/19°CWB		28°CDB/20°CWB		30°CDB/22°CWB		32°CDB/23°CWB	
		68°FDB/59°FWB		73°FDB/61°FWB		79°FDB/64°FWB		81°FDB/66°FWB		82°FDB/68°FWB		86°FDB/72°FWB		90°FDB/73°FWB	
(°CDB)	(°FDB)	TC	SHC	TC	SHC	TC	SHC	TC	SHC	TC	SHC	TC	SHC	TC	SHC
10	50	5.08	3.76	5.57	4.56	6.56	5.11	7.05	5.22	7.54	5.28	8.60	5.43	9.02	5.79
15	59	5.08	3.76	5.57	4.56	6.56	5.11	7.05	5.22	7.54	5.28	8.60	5.43	9.02	5.79
21	70	5.08	3.76	5.57	4.56	6.56	5.11	7.05	5.22	7.54	5.28	8.46	5.43	8.60	5.69
23	73	5.08	3.76	5.57	4.56	6.56	5.11	7.05	5.22	7.54	5.28	8.32	5.34	8.53	5.64
25	77	5.08	3.76	5.57	4.56	6.56	5.11	7.05	5.22	7.54	5.28	8.18	5.33	8.39	5.63
27	81	5.08	3.76	5.57	4.56	6.56	5.11	7.05	5.22	7.54	5.28	8.04	5.23	8.25	5.53
30	86	5.08	3.76	5.57	4.56	6.56	5.11	7.05	5.22	7.54	5.28	7.90	5.22	8.04	5.47
33	91	5.08	3.76	5.57	4.56	6.56	5.11	7.05	5.22	7.33	5.21	7.68	5.16	7.83	5.40
35	95	5.08	3.76	5.57	4.56	6.56	5.11	7.05	5.22	7.19	5.18	7.54	5.06	7.68	5.31
37	99	5.08	3.76	5.57	4.56	6.56	5.11	6.91	5.18	7.05	5.15	7.40	5.04	7.54	5.28
40	104	5.08	3.76	5.57	4.56	6.56	5.11	6.70	5.09	6.84	5.06	7.12	4.92	7.26	5.23
43	109	5.08	3.76	5.57	4.56	6.27	5.01	6.42	4.94	6.56	4.92	6.84	4.86	6.98	5.10

MODEL : AR30

Outdoor Temperature		Indoor Temperature													
		20°CDB/15°CWB		23°CDB/16°CWB		26°CDB/18°CWB		27°CDB/19°CWB		28°CDB/20°CWB		30°CDB/22°CWB		32°CDB/23°CWB	
		68°FDB/59°FWB		73°FDB/61°FWB		79°FDB/64°FWB		81°FDB/66°FWB		82°FDB/68°FWB		86°FDB/72°FWB		90°FDB/73°FWB	
(°CDB)	(°FDB)	TC	SHC	TC	SHC	TC	SHC	TC	SHC	TC	SHC	TC	SHC	TC	SHC
10	50	6.34	4.56	6.95	5.44	8.18	6.07	8.80	6.25	9.42	6.39	10.7	6.61	11.3	6.94
15	59	6.34	4.56	6.95	5.44	8.18	6.07	8.80	6.25	9.42	6.39	10.7	6.61	11.3	6.94
21	70	6.34	4.56	6.95	5.44	8.18	6.07	8.80	6.25	9.42	6.39	10.6	6.51	10.7	6.73
23	73	6.34	4.56	6.95	5.44	8.18	6.07	8.80	6.25	9.42	6.39	10.4	6.40	10.6	6.67
25	77	6.34	4.56	6.95	5.44	8.18	6.07	8.80	6.25	9.42	6.39	10.2	6.40	10.5	6.67
27	81	6.34	4.56	6.95	5.44	8.18	6.07	8.80	6.25	9.42	6.39	10.0	6.28	10.3	6.56
30	86	6.34	4.56	6.95	5.44	8.18	6.07	8.80	6.25	9.42	6.39	9.86	6.17	10.0	6.49
33	91	6.34	4.56	6.95	5.44	8.18	6.07	8.80	6.25	9.15	6.21	9.59	6.11	9.77	6.32
35	95	6.34	4.56	6.95	5.44	8.18	6.07	8.80	6.25	8.98	6.19	9.42	6.00	9.59	6.31
37	99	6.34	4.56	6.95	5.44	8.18	6.07	8.62	6.12	8.80	6.06	9.24	5.98	9.42	6.19
40	104	6.34	4.56	6.95	5.44	8.18	6.07	8.36	6.02	8.54	5.97	8.89	5.85	9.06	6.06
43	109	6.34	4.56	6.95	5.44	7.83	5.89	8.01	5.85	8.18	5.81	8.54	5.70	8.71	5.91

MODEL : AR36

Outdoor Temperature		Indoor Temperature													
		20°CDB/15°CWB		23°CDB/16°CWB		26°CDB/18°CWB		27°CDB/19°CWB		28°CDB/20°CWB		30°CDB/22°CWB		32°CDB/23°CWB	
		68°FDB/59°FWB		73°FDB/61°FWB		79°FDB/64°FWB		81°FDB/66°FWB		82°FDB/68°FWB		86°FDB/72°FWB		90°FDB/73°FWB	
(°CDB)	(°FDB)	TC	SHC	TC	SHC	TC	SHC	TC	SHC	TC	SHC	TC	SHC	TC	SHC
10	50	7.56	5.37	8.30	6.42	9.77	7.15	10.5	7.35	11.2	7.51	12.8	7.88	13.4	8.27
15	59	7.56	5.37	8.30	6.42	9.77	7.15	10.5	7.35	11.2	7.51	12.8	7.88	13.4	8.27
21	70	7.56	5.37	8.30	6.42	9.77	7.15	10.5	7.35	11.2	7.51	12.6	7.75	12.8	8.02
23	73	7.56	5.37	8.30	6.42	9.77	7.15	10.5	7.35	11.2	7.51	12.4	7.62	12.7	7.95
25	77	7.56	5.37	8.30	6.42	9.77	7.15	10.5	7.35	11.2	7.51	12.2	7.62	12.5	7.82
27	81	7.56	5.37	8.30	6.42	9.77	7.15	10.5	7.35	11.2	7.51	12.0	7.49	12.3	7.82
30	86	7.56	5.37	8.30	6.42	9.77	7.15	10.5	7.35	11.2	7.51	11.8	7.36	12.0	7.62
33	91	7.56	5.37	8.30	6.42	9.77	7.15	10.5	7.35	10.9	7.41	11.4	7.28	11.7	7.54
35	95	7.56	5.37	8.30	6.42	9.77	7.15	10.5	7.35	10.7	7.27	11.2	7.15	11.4	7.40
37	99	7.56	5.37	8.30	6.42	9.77	7.15	10.3	7.31	10.5	7.24	11.0	7.02	11.2	7.27
40	104	7.56	5.37	8.30	6.42	9.77	7.15	9.98	7.09	10.2	7.02	10.6	6.86	10.8	7.11
43	109	7.56	5.37	8.30	6.42	9.35	6.94	9.56	6.89	9.77	6.84	10.2	6.70	10.4	6.95

MODEL : AR45

Outdoor Temperature		Indoor Temperature													
		20°CDB/15°CWB		23°CDB/16°CWB		26°CDB/18°CWB		27°CDB/19°CWB		28°CDB/20°CWB		30°CDB/22°CWB		32°CDB/23°CWB	
		68°FDB/59°FWB		73°FDB/61°FWB		79°FDB/64°FWB		81°FDB/66°FWB		82°FDB/68°FWB		86°FDB/72°FWB		90°FDB/73°FWB	
(°CDB)	(°FDB)	TC	SHC	TC	SHC	TC	SHC	TC	SHC	TC	SHC	TC	SHC	TC	SHC
10	50	9.14	6.59	10.0	7.85	11.8	8.87	12.7	9.02	13.6	9.23	15.5	9.57	16.3	10.2
15	59	9.14	6.59	10.0	7.85	11.8	8.87	12.7	9.02	13.6	9.23	15.5	9.57	16.3	10.2
21	70	9.14	6.59	10.0	7.85	11.8	8.87	12.7	9.02	13.6	9.23	15.2	9.41	15.5	9.88
23	73	9.14	6.59	10.0	7.85	11.8	8.87	12.7	9.02	13.6	9.23	15.0	9.41	15.4	9.80
25	77	9.14	6.59	10.0	7.85	11.8	8.87	12.7	9.02	13.6	9.23	14.7	9.25	15.1	9.64
27	81	9.14	6.59	10.0	7.85	11.8	8.87	12.7	9.02	13.6	9.23	14.5	9.09	14.9	9.63
30	86	9.14	6.59	10.0	7.85	11.8	8.87	12.7	9.02	13.6	9.23	14.2	9.07	14.5	9.39
33	91	9.14	6.59	10.0	7.85	11.8	8.87	12.7	9.02	13.2	9.11	13.8	8.83	14.1	9.28
35	95	9.14	6.59	10.0	7.85	11.8	8.87	12.7	9.02	13.0	8.93	13.6	8.81	13.8	9.12
37	99	9.14	6.59	10.0	7.85	11.8	8.87	12.4	8.96	12.7	8.89	13.3	8.64	13.6	9.09
40	104	9.14	6.59	10.0	7.85	11.8	8.87	12.1	8.81	12.3	8.62	12.8	8.45	13.1	8.88
43	109	9.14	6.59	10.0	7.85	11.3	8.61	11.6	8.56	11.8	8.51	12.3	8.24	12.6	8.67

TC : Total Capacity kW
 SHC : Sensible Heat Capacity kW

The data is based on the following conditions. Pipe length : 7.5m ; Height difference : 0 m ; Static pressure : 100 Pa.

4-8-4. COMPACT CASSETTE TYPE (1/2)

COOLING CAPACITY

MODEL : AU7

Outdoor Temperature (°CDB) (°FDB)		Indoor Temperature													
		20°CDB/15°CWB		23°CDB/16°CWB		26°CDB/18°CWB		27°CDB/19°CWB		28°CDB/20°CWB		30°CDB/22°CWB		32°CDB/23°CWB	
		TC	SHC	TC	SHC	TC	SHC	TC	SHC	TC	SHC	TC	SHC	TC	SHC
10	50	1.55	1.12	1.70	1.33	2.00	1.48	2.15	1.53	2.30	1.56	2.62	1.64	2.75	1.72
15	59	1.55	1.12	1.70	1.33	2.00	1.48	2.15	1.53	2.30	1.56	2.62	1.64	2.75	1.72
21	70	1.55	1.12	1.70	1.33	2.00	1.48	2.15	1.53	2.30	1.56	2.58	1.61	2.62	1.67
23	73	1.55	1.12	1.70	1.33	2.00	1.48	2.15	1.53	2.30	1.56	2.54	1.59	2.60	1.65
25	77	1.55	1.12	1.70	1.33	2.00	1.48	2.15	1.53	2.30	1.56	2.49	1.56	2.56	1.63
27	81	1.55	1.12	1.70	1.33	2.00	1.48	2.15	1.53	2.30	1.56	2.45	1.56	2.52	1.60
30	86	1.55	1.12	1.70	1.33	2.00	1.48	2.15	1.53	2.30	1.56	2.41	1.53	2.45	1.58
33	91	1.55	1.12	1.70	1.33	2.00	1.48	2.15	1.53	2.24	1.54	2.34	1.49	2.39	1.54
35	95	1.55	1.12	1.70	1.33	2.00	1.48	2.15	1.53	2.19	1.51	2.30	1.49	2.34	1.54
37	99	1.55	1.12	1.70	1.33	2.00	1.48	2.11	1.50	2.15	1.48	2.26	1.46	2.30	1.51
40	104	1.55	1.12	1.70	1.33	2.00	1.48	2.04	1.47	2.09	1.46	2.17	1.43	2.21	1.48
43	109	1.55	1.12	1.70	1.33	1.91	1.44	1.96	1.43	2.00	1.42	2.09	1.39	2.13	1.44

MODEL : AU9

Outdoor Temperature (°CDB) (°FDB)		Indoor Temperature													
		20°CDB/15°CWB		23°CDB/16°CWB		26°CDB/18°CWB		27°CDB/19°CWB		28°CDB/20°CWB		30°CDB/22°CWB		32°CDB/23°CWB	
		TC	SHC	TC	SHC	TC	SHC	TC	SHC	TC	SHC	TC	SHC	TC	SHC
10	50	2.02	1.43	2.21	1.71	2.60	1.90	2.80	1.96	3.00	2.00	3.42	2.11	3.58	2.21
15	59	2.02	1.43	2.21	1.71	2.60	1.90	2.80	1.96	3.00	2.00	3.42	2.11	3.58	2.21
21	70	2.02	1.43	2.21	1.71	2.60	1.90	2.80	1.96	3.00	2.00	3.36	2.07	3.42	2.14
23	73	2.02	1.43	2.21	1.71	2.60	1.90	2.80	1.96	3.00	2.00	3.30	2.04	3.39	2.12
25	77	2.02	1.43	2.21	1.71	2.60	1.90	2.80	1.96	3.00	2.00	3.25	2.00	3.33	2.09
27	81	2.02	1.43	2.21	1.71	2.60	1.90	2.80	1.96	3.00	2.00	3.19	2.00	3.28	2.05
30	86	2.02	1.43	2.21	1.71	2.60	1.90	2.80	1.96	3.00	2.00	3.14	1.97	3.19	2.03
33	91	2.02	1.43	2.21	1.71	2.60	1.90	2.80	1.96	2.91	1.98	3.05	1.91	3.11	2.01
35	95	2.02	1.43	2.21	1.71	2.60	1.90	2.80	1.96	2.86	1.94	3.00	1.91	3.05	1.98
37	99	2.02	1.43	2.21	1.71	2.60	1.90	2.74	1.95	2.80	1.90	2.94	1.87	3.00	1.94
40	104	2.02	1.43	2.21	1.71	2.60	1.90	2.66	1.89	2.72	1.87	2.83	1.83	2.88	1.90
43	109	2.02	1.43	2.21	1.71	2.49	1.85	2.55	1.84	2.60	1.82	2.72	1.79	2.77	1.85

MODEL : AU12

Outdoor Temperature (°CDB) (°FDB)		Indoor Temperature													
		20°CDB/15°CWB		23°CDB/16°CWB		26°CDB/18°CWB		27°CDB/19°CWB		28°CDB/20°CWB		30°CDB/22°CWB		32°CDB/23°CWB	
		TC	SHC	TC	SHC	TC	SHC	TC	SHC	TC	SHC	TC	SHC	TC	SHC
10	50	2.59	1.84	2.84	2.19	3.35	2.48	3.60	2.56	3.85	2.58	4.39	2.67	4.61	2.84
15	59	2.59	1.84	2.84	2.19	3.35	2.48	3.60	2.56	3.85	2.58	4.39	2.67	4.61	2.84
21	70	2.59	1.84	2.84	2.19	3.35	2.48	3.60	2.56	3.85	2.58	4.32	2.67	4.39	2.76
23	73	2.59	1.84	2.84	2.19	3.35	2.48	3.60	2.56	3.85	2.58	4.25	2.62	4.36	2.73
25	77	2.59	1.84	2.84	2.19	3.35	2.48	3.60	2.56	3.85	2.58	4.18	2.58	4.28	2.69
27	81	2.59	1.84	2.84	2.19	3.35	2.48	3.60	2.56	3.85	2.58	4.10	2.58	4.21	2.69
30	86	2.59	1.84	2.84	2.19	3.35	2.48	3.60	2.56	3.85	2.58	4.03	2.53	4.10	2.66
33	91	2.59	1.84	2.84	2.19	3.35	2.48	3.60	2.56	3.74	2.54	3.92	2.50	4.00	2.59
35	95	2.59	1.84	2.84	2.19	3.35	2.48	3.60	2.56	3.67	2.49	3.85	2.46	3.92	2.54
37	99	2.59	1.84	2.84	2.19	3.35	2.48	3.53	2.50	3.60	2.48	3.78	2.41	3.85	2.54
40	104	2.59	1.84	2.84	2.19	3.35	2.48	3.42	2.46	3.49	2.44	3.64	2.36	3.71	2.48
43	109	2.59	1.84	2.84	2.19	3.20	2.41	3.28	2.39	3.35	2.38	3.49	2.30	3.56	2.42

TC : Total Capacity kW

SHC : Sensible Heat Capacity kW

The data is based on the following conditions. Pipe length : 7.5m ; Height difference : 0 m.

4-8-4. COMPACT CASSETTE TYPE (2/2)

COOLING CAPACITY

MODEL : AU14

Outdoor Temperature		Indoor Temperature													
		20°CDB/15°CWB		23°CDB/16°CWB		26°CDB/18°CWB		27°CDB/19°CWB		28°CDB/20°CWB		30°CDB/22°CWB		32°CDB/23°CWB	
		68°FDB/59°FWB		73°FDB/61°FWB		79°FDB/64°FWB		81°FDB/66°FWB		82°FDB/68°FWB		86°FDB/72°FWB		90°FDB/73°FWB	
(°CDB)	(°FDB)	TC	SHC	TC	SHC	TC	SHC	TC	SHC	TC	SHC	TC	SHC	TC	SHC
10	50	2.88	2.07	3.16	2.47	3.72	2.80	4.00	2.84	4.28	2.90	4.88	3.01	5.12	3.21
15	59	2.88	2.07	3.16	2.47	3.72	2.80	4.00	2.84	4.28	2.90	4.88	3.01	5.12	3.21
21	70	2.88	2.07	3.16	2.47	3.72	2.80	4.00	2.84	4.28	2.90	4.80	2.96	4.88	3.11
23	73	2.88	2.07	3.16	2.47	3.72	2.80	4.00	2.84	4.28	2.90	4.72	2.96	4.84	3.08
25	77	2.88	2.07	3.16	2.47	3.72	2.80	4.00	2.84	4.28	2.90	4.64	2.91	4.76	3.03
27	81	2.88	2.07	3.16	2.47	3.72	2.80	4.00	2.84	4.28	2.90	4.56	2.86	4.68	2.98
30	86	2.88	2.07	3.16	2.47	3.72	2.80	4.00	2.84	4.28	2.90	4.48	2.85	4.56	2.95
33	91	2.88	2.07	3.16	2.47	3.72	2.80	4.00	2.84	4.16	2.87	4.36	2.78	4.44	2.87
35	95	2.88	2.07	3.16	2.47	3.72	2.80	4.00	2.84	4.08	2.81	4.28	2.77	4.36	2.87
37	99	2.88	2.07	3.16	2.47	3.72	2.80	3.92	2.82	4.00	2.76	4.20	2.72	4.28	2.82
40	104	2.88	2.07	3.16	2.47	3.72	2.80	3.80	2.74	3.88	2.71	4.04	2.66	4.12	2.75
43	109	2.88	2.07	3.16	2.47	3.56	2.71	3.64	2.66	3.72	2.64	3.88	2.59	3.96	2.73

MODEL : AU18

Outdoor Temperature		Indoor Temperature													
		20°CDB/15°CWB		23°CDB/16°CWB		26°CDB/18°CWB		27°CDB/19°CWB		28°CDB/20°CWB		30°CDB/22°CWB		32°CDB/23°CWB	
		68°FDB/59°FWB		73°FDB/61°FWB		79°FDB/64°FWB		81°FDB/66°FWB		82°FDB/68°FWB		86°FDB/72°FWB		90°FDB/73°FWB	
(°CDB)	(°FDB)	TC	SHC	TC	SHC	TC	SHC	TC	SHC	TC	SHC	TC	SHC	TC	SHC
10	50	3.60	2.59	3.95	3.13	4.65	3.49	5.00	3.55	5.35	3.64	6.10	3.77	6.40	3.96
15	59	3.60	2.59	3.95	3.13	4.65	3.49	5.00	3.55	5.35	3.64	6.10	3.77	6.40	3.96
21	70	3.60	2.59	3.95	3.13	4.65	3.49	5.00	3.55	5.35	3.64	6.00	3.71	6.10	3.84
23	73	3.60	2.59	3.95	3.13	4.65	3.49	5.00	3.55	5.35	3.64	5.90	3.65	6.05	3.87
25	77	3.60	2.59	3.95	3.13	4.65	3.49	5.00	3.55	5.35	3.64	5.80	3.65	5.95	3.80
27	81	3.60	2.59	3.95	3.13	4.65	3.49	5.00	3.55	5.35	3.64	5.70	3.58	5.85	3.74
30	86	3.60	2.59	3.95	3.13	4.65	3.49	5.00	3.55	5.35	3.64	5.60	3.58	5.70	3.70
33	91	3.60	2.59	3.95	3.13	4.65	3.49	5.00	3.55	5.20	3.59	5.45	3.48	5.55	3.66
35	95	3.60	2.59	3.95	3.13	4.65	3.49	5.00	3.55	5.10	3.52	5.35	3.47	5.45	3.59
37	99	3.60	2.59	3.95	3.13	4.65	3.49	4.90	3.53	5.00	3.50	5.25	3.41	5.35	3.58
40	104	3.60	2.59	3.95	3.13	4.65	3.49	4.75	3.47	4.85	3.39	5.05	3.33	5.15	3.50
43	109	3.60	2.59	3.95	3.13	4.45	3.39	4.55	3.37	4.65	3.35	4.85	3.25	4.95	3.41

TC : Total Capacity kW
 SHC : Sensible Heat Capacity kW

The data is based on the following conditions. Pipe length : 7.5m ; Height difference : 0 m.

4-8-5. CASSETTE TYPE (1/2)

COOLING CAPACITY

MODEL : AU20

Outdoor Temperature		Indoor Temperature													
		20°CDB/15°CWB		23°CDB/16°CWB		26°CDB/18°CWB		27°CDB/19°CWB		28°CDB/20°CWB		30°CDB/22°CWB		32°CDB/23°CWB	
		68°FDB/59°FWB		73°FDB/61°FWB		79°FDB/64°FWB		81°FDB/66°FWB		82°FDB/68°FWB		86°FDB/72°FWB		90°FDB/73°FWB	
(°CDB)	(°FDB)	TC	SHC	TC	SHC	TC	SHC	TC	SHC	TC	SHC	TC	SHC	TC	SHC
10	50	4.10	2.87	4.50	3.47	5.30	3.87	5.70	3.99	6.10	4.03	6.95	4.17	7.30	4.45
15	59	4.10	2.87	4.50	3.47	5.30	3.87	5.70	3.99	6.10	4.03	6.95	4.17	7.30	4.45
21	70	4.10	2.87	4.50	3.47	5.30	3.87	5.70	3.99	6.10	4.03	6.84	4.17	6.95	4.31
23	73	4.10	2.87	4.50	3.47	5.30	3.87	5.70	3.99	6.10	4.03	6.73	4.10	6.90	4.28
25	77	4.10	2.87	4.50	3.47	5.30	3.87	5.70	3.99	6.10	4.03	6.61	4.03	6.78	4.21
27	81	4.10	2.87	4.50	3.47	5.30	3.87	5.70	3.99	6.10	4.03	6.50	4.03	6.67	4.20
30	86	4.10	2.87	4.50	3.47	5.30	3.87	5.70	3.99	6.10	4.03	6.38	3.96	6.50	4.09
33	91	4.10	2.87	4.50	3.47	5.30	3.87	5.70	3.99	5.93	3.97	6.21	3.91	6.33	4.05
35	95	4.10	2.87	4.50	3.47	5.30	3.87	5.70	3.99	5.81	3.90	6.10	3.84	6.21	4.04
37	99	4.10	2.87	4.50	3.47	5.30	3.87	5.59	3.91	5.70	3.88	5.99	3.77	6.10	3.96
40	104	4.10	2.87	4.50	3.47	5.30	3.87	5.42	3.84	5.53	3.82	5.76	3.68	5.87	3.87
43	109	4.10	2.87	4.50	3.47	5.07	3.75	5.19	3.73	5.30	3.71	5.53	3.59	5.64	3.78

MODEL : AU25

Outdoor Temperature		Indoor Temperature													
		20°CDB/15°CWB		23°CDB/16°CWB		26°CDB/18°CWB		27°CDB/19°CWB		28°CDB/20°CWB		30°CDB/22°CWB		32°CDB/23°CWB	
		68°FDB/59°FWB		73°FDB/61°FWB		79°FDB/64°FWB		81°FDB/66°FWB		82°FDB/68°FWB		86°FDB/72°FWB		90°FDB/73°FWB	
(°CDB)	(°FDB)	TC	SHC	TC	SHC	TC	SHC	TC	SHC	TC	SHC	TC	SHC	TC	SHC
10	50	5.08	3.71	5.57	4.50	6.56	5.04	7.05	5.15	7.54	5.21	8.60	5.36	9.02	5.71
15	59	5.08	3.71	5.57	4.50	6.56	5.04	7.05	5.15	7.54	5.21	8.60	5.36	9.02	5.71
21	70	5.08	3.71	5.57	4.50	6.56	5.04	7.05	5.15	7.54	5.21	8.46	5.35	8.60	5.61
23	73	5.08	3.71	5.57	4.50	6.56	5.04	7.05	5.15	7.54	5.21	8.32	5.26	8.53	5.56
25	77	5.08	3.71	5.57	4.50	6.56	5.04	7.05	5.15	7.54	5.21	8.18	5.25	8.39	5.47
27	81	5.08	3.71	5.57	4.50	6.56	5.04	7.05	5.15	7.54	5.21	8.04	5.16	8.25	5.46
30	86	5.08	3.71	5.57	4.50	6.56	5.04	7.05	5.15	7.54	5.21	7.90	5.15	8.04	5.40
33	91	5.08	3.71	5.57	4.50	6.56	5.04	7.05	5.15	7.33	5.14	7.68	5.01	7.83	5.33
35	95	5.08	3.71	5.57	4.50	6.56	5.04	7.05	5.15	7.19	5.11	7.54	4.99	7.68	5.24
37	99	5.08	3.71	5.57	4.50	6.56	5.04	6.91	5.11	7.05	5.01	7.40	4.97	7.54	5.21
40	104	5.08	3.71	5.57	4.50	6.56	5.04	6.70	5.02	6.84	4.93	7.12	4.85	7.26	5.09
43	109	5.08	3.71	5.57	4.50	6.27	4.95	6.42	4.87	6.56	4.85	6.84	4.73	6.98	5.03

MODEL : AU30

Outdoor Temperature		Indoor Temperature													
		20°CDB/15°CWB		23°CDB/16°CWB		26°CDB/18°CWB		27°CDB/19°CWB		28°CDB/20°CWB		30°CDB/22°CWB		32°CDB/23°CWB	
		68°FDB/59°FWB		73°FDB/61°FWB		79°FDB/64°FWB		81°FDB/66°FWB		82°FDB/68°FWB		86°FDB/72°FWB		90°FDB/73°FWB	
(°CDB)	(°FDB)	TC	SHC	TC	SHC	TC	SHC	TC	SHC	TC	SHC	TC	SHC	TC	SHC
10	50	6.34	4.44	6.95	5.29	8.18	5.90	8.80	6.07	9.42	6.21	10.7	6.43	11.3	6.74
15	59	6.34	4.44	6.95	5.29	8.18	5.90	8.80	6.07	9.42	6.21	10.7	6.43	11.3	6.74
21	70	6.34	4.44	6.95	5.29	8.18	5.90	8.80	6.07	9.42	6.21	10.6	6.32	10.7	6.54
23	73	6.34	4.44	6.95	5.29	8.18	5.90	8.80	6.07	9.42	6.21	10.4	6.22	10.6	6.48
25	77	6.34	4.44	6.95	5.29	8.18	5.90	8.80	6.07	9.42	6.21	10.2	6.21	10.5	6.48
27	81	6.34	4.44	6.95	5.29	8.18	5.90	8.80	6.07	9.42	6.21	10.0	6.11	10.3	6.37
30	86	6.34	4.44	6.95	5.29	8.18	5.90	8.80	6.07	9.42	6.21	9.86	6.00	10.0	6.31
33	91	6.34	4.44	6.95	5.29	8.18	5.90	8.80	6.07	9.15	6.04	9.59	5.94	9.77	6.15
35	95	6.34	4.44	6.95	5.29	8.18	5.90	8.80	6.07	8.98	6.01	9.42	5.83	9.59	6.13
37	99	6.34	4.44	6.95	5.29	8.18	5.90	8.62	5.95	8.80	5.89	9.24	5.81	9.42	6.02
40	104	6.34	4.44	6.95	5.29	8.18	5.90	8.36	5.85	8.54	5.80	8.89	5.68	9.06	5.89
43	109	6.34	4.44	6.95	5.29	7.83	5.72	8.01	5.69	8.18	5.65	8.54	5.54	8.71	5.75

MODEL : AU36

Outdoor Temperature		Indoor Temperature													
		20°CDB/15°CWB		23°CDB/16°CWB		26°CDB/18°CWB		27°CDB/19°CWB		28°CDB/20°CWB		30°CDB/22°CWB		32°CDB/23°CWB	
		68°FDB/59°FWB		73°FDB/61°FWB		79°FDB/64°FWB		81°FDB/66°FWB		82°FDB/68°FWB		86°FDB/72°FWB		90°FDB/73°FWB	
(°CDB)	(°FDB)	TC	SHC	TC	SHC	TC	SHC	TC	SHC	TC	SHC	TC	SHC	TC	SHC
10	50	7.56	5.22	8.30	6.24	9.77	7.04	10.5	7.14	11.2	7.29	12.8	7.65	13.4	8.03
15	59	7.56	5.22	8.30	6.24	9.77	7.04	10.5	7.14	11.2	7.29	12.8	7.65	13.4	8.03
21	70	7.56	5.22	8.30	6.24	9.77	7.04	10.5	7.14	11.2	7.29	12.6	7.53	12.8	7.79
23	73	7.56	5.22	8.30	6.24	9.77	7.04	10.5	7.14	11.2	7.29	12.4	7.40	12.7	7.72
25	77	7.56	5.22	8.30	6.24	9.77	7.04	10.5	7.14	11.2	7.29	12.2	7.40	12.5	7.60
27	81	7.56	5.22	8.30	6.24	9.77	7.04	10.5	7.14	11.2	7.29	12.0	7.28	12.3	7.59
30	86	7.56	5.22	8.30	6.24	9.77	7.04	10.5	7.14	11.2	7.29	11.8	7.15	12.0	7.40
33	91	7.56	5.22	8.30	6.24	9.77	7.04	10.5	7.14	10.9	7.20	11.4	7.08	11.7	7.32
35	95	7.56	5.22	8.30	6.24	9.77	7.04	10.5	7.14	10.7	7.06	11.2	6.95	11.4	7.19
37	99	7.56	5.22	8.30	6.24	9.77	7.04	10.3	7.10	10.5	7.03	11.0	6.82	11.2	7.06
40	104	7.56	5.22	8.30	6.24	9.77	7.04	9.98	6.89	10.2	6.82	10.6	6.67	10.8	6.91
43	109	7.56	5.22	8.30	6.24	9.35	6.74	9.56	6.69	9.77	6.64	10.2	6.51	10.4	6.75

TC : Total Capacity kW

SHC : Sensible Heat Capacity kW

The data is based on the following conditions. Pipe length : 7.5m ; Height difference : 0 m.

4-8-5. CASSETTE TYPE (2/2)

COOLING CAPACITY

MODEL : AU45

Outdoor Temperature		Indoor Temperature													
		20°CDB/15°CWB 68°FDB/59°FWB		23°CDB/16°CWB 73°FDB/61°FWB		26°CDB/18°CWB 79°FDB/64°FWB		27°CDB/19°CWB 81°FDB/66°FWB		28°CDB/20°CWB 82°FDB/68°FWB		30°CDB/22°CWB 86°FDB/72°FWB		32°CDB/23°CWB 90°FDB/73°FWB	
(°CDB)	(°FDB)	TC	SHC	TC	SHC	TC	SHC	TC	SHC	TC	SHC	TC	SHC	TC	SHC
10	50	9.14	6.40	10.0	7.65	11.8	8.64	12.7	8.89	13.6	9.09	15.5	9.39	16.3	9.85
15	59	9.14	6.40	10.0	7.65	11.8	8.64	12.7	8.89	13.6	9.09	15.5	9.39	16.3	9.85
21	70	9.14	6.40	10.0	7.65	11.8	8.64	12.7	8.89	13.6	9.09	15.2	9.23	15.5	9.55
23	73	9.14	6.40	10.0	7.65	11.8	8.64	12.7	8.89	13.6	9.09	15.0	9.24	15.4	9.47
25	77	9.14	6.40	10.0	7.65	11.8	8.64	12.7	8.89	13.6	9.09	14.7	9.08	15.1	9.47
27	81	9.14	6.40	10.0	7.65	11.8	8.64	12.7	8.89	13.6	9.09	14.5	8.92	14.9	9.31
30	86	9.14	6.40	10.0	7.65	11.8	8.64	12.7	8.89	13.6	9.09	14.2	8.77	14.5	9.08
33	91	9.14	6.40	10.0	7.65	11.8	8.64	12.7	8.89	13.2	8.83	13.8	8.68	14.1	8.98
35	95	9.14	6.40	10.0	7.65	11.8	8.64	12.7	8.89	13.0	8.66	13.6	8.52	13.8	8.82
37	99	9.14	6.40	10.0	7.65	11.8	8.64	12.4	8.71	12.7	8.62	13.3	8.36	13.6	8.80
40	104	9.14	6.40	10.0	7.65	11.8	8.64	12.1	8.57	12.3	8.37	12.8	8.17	13.1	8.61
43	109	9.14	6.40	10.0	7.65	11.3	8.38	11.6	8.33	11.8	8.14	12.3	7.98	12.6	8.41

MODEL : AU54

Outdoor Temperature		Indoor Temperature													
		20°CDB/15°CWB 68°FDB/59°FWB		23°CDB/16°CWB 73°FDB/61°FWB		26°CDB/18°CWB 79°FDB/64°FWB		27°CDB/19°CWB 81°FDB/66°FWB		28°CDB/20°CWB 82°FDB/68°FWB		30°CDB/22°CWB 86°FDB/72°FWB		32°CDB/23°CWB 90°FDB/73°FWB	
(°CDB)	(°FDB)	TC	SHC	TC	SHC	TC	SHC	TC	SHC	TC	SHC	TC	SHC	TC	SHC
10	50	10.2	7.11	11.1	8.49	13.1	9.59	14.1	9.73	15.1	9.94	17.2	10.5	18.0	10.8
15	59	10.2	7.11	11.1	8.49	13.1	9.59	14.1	9.73	15.1	9.94	17.2	10.5	18.0	10.8
21	70	10.2	7.11	11.1	8.49	13.1	9.59	14.1	9.73	15.1	9.94	16.9	10.3	17.2	10.6
23	73	10.2	7.11	11.1	8.49	13.1	9.59	14.1	9.73	15.1	9.94	16.6	10.1	17.1	10.5
25	77	10.2	7.11	11.1	8.49	13.1	9.59	14.1	9.73	15.1	9.94	16.4	9.94	16.8	10.4
27	81	10.2	7.11	11.1	8.49	13.1	9.59	14.1	9.73	15.1	9.94	16.1	9.93	16.5	10.2
30	86	10.2	7.11	11.1	8.49	13.1	9.59	14.1	9.73	15.1	9.94	15.8	9.76	16.1	10.1
33	91	10.2	7.11	11.1	8.49	13.1	9.59	14.1	9.73	14.7	9.82	15.4	9.65	15.7	9.99
35	95	10.2	7.11	11.1	8.49	13.1	9.59	14.1	9.73	14.4	9.63	15.1	9.48	15.4	9.81
37	99	10.2	7.11	11.1	8.49	13.1	9.59	13.8	9.68	14.1	9.58	14.8	9.30	15.1	9.79
40	104	10.2	7.11	11.1	8.49	13.1	9.59	13.4	9.38	13.7	9.30	14.2	9.09	14.5	9.57
43	109	10.2	7.11	11.1	8.49	12.5	9.30	12.8	9.25	13.1	9.05	13.7	8.87	14.0	9.34

TC : Total Capacity kW
SHC : Sensible Heat Capacity kW

The data is based on the following conditions. Pipe length : 7.5m ; Height difference : 0 m.

4-8-6. COMPACT WALL MOUNTED TYPE

COOLING CAPACITY

MODEL : AS7

Outdoor Temperature		Indoor Temperature													
		20°CDB/15°CWB		23°CDB/16°CWB		26°CDB/18°CWB		27°CDB/19°CWB		28°CDB/20°CWB		30°CDB/22°CWB		32°CDB/23°CWB	
		68°FDB/59°FWB		73°FDB/61°FWB		79°FDB/64°FWB		81°FDB/66°FWB		82°FDB/68°FWB		86°FDB/72°FWB		90°FDB/73°FWB	
(°CDB)	(°FDB)	TC	SHC	TC	SHC	TC	SHC	TC	SHC	TC	SHC	TC	SHC	TC	SHC
10	50	1.55	1.21	1.70	1.44	2.00	1.61	2.15	1.66	2.30	1.69	2.62	1.75	2.75	1.87
15	59	1.55	1.21	1.70	1.44	2.00	1.61	2.15	1.66	2.30	1.69	2.62	1.75	2.75	1.87
21	70	1.55	1.21	1.70	1.44	2.00	1.61	2.15	1.66	2.30	1.69	2.58	1.75	2.62	1.81
23	73	1.55	1.21	1.70	1.44	2.00	1.61	2.15	1.66	2.30	1.69	2.54	1.72	2.60	1.79
25	77	1.55	1.21	1.70	1.44	2.00	1.61	2.15	1.66	2.30	1.69	2.49	1.69	2.56	1.76
27	81	1.55	1.21	1.70	1.44	2.00	1.61	2.15	1.66	2.30	1.69	2.45	1.69	2.52	1.73
30	86	1.55	1.21	1.70	1.44	2.00	1.61	2.15	1.66	2.30	1.69	2.41	1.66	2.45	1.72
33	91	1.55	1.21	1.70	1.44	2.00	1.61	2.15	1.66	2.24	1.67	2.34	1.62	2.39	1.67
35	95	1.55	1.21	1.70	1.44	2.00	1.61	2.15	1.66	2.19	1.64	2.30	1.61	2.34	1.67
37	99	1.55	1.21	1.70	1.44	2.00	1.61	2.11	1.62	2.15	1.61	2.26	1.58	2.30	1.64
40	104	1.55	1.21	1.70	1.44	2.00	1.61	2.04	1.60	2.09	1.58	2.17	1.55	2.21	1.60
43	109	1.55	1.21	1.70	1.44	1.91	1.56	1.96	1.55	2.00	1.54	2.09	1.51	2.13	1.57

MODEL : AS9

Outdoor Temperature		Indoor Temperature													
		20°CDB/15°CWB		23°CDB/16°CWB		26°CDB/18°CWB		27°CDB/19°CWB		28°CDB/20°CWB		30°CDB/22°CWB		32°CDB/23°CWB	
		68°FDB/59°FWB		73°FDB/61°FWB		79°FDB/64°FWB		81°FDB/66°FWB		82°FDB/68°FWB		86°FDB/72°FWB		90°FDB/73°FWB	
(°CDB)	(°FDB)	TC	SHC	TC	SHC	TC	SHC	TC	SHC	TC	SHC	TC	SHC	TC	SHC
10	50	2.02	1.51	2.21	1.81	2.60	2.01	2.80	2.07	3.00	2.12	3.42	2.23	3.58	2.34
15	59	2.02	1.51	2.21	1.81	2.60	2.01	2.80	2.07	3.00	2.12	3.42	2.23	3.58	2.34
21	70	2.02	1.51	2.21	1.81	2.60	2.01	2.80	2.07	3.00	2.12	3.36	2.19	3.42	2.26
23	73	2.02	1.51	2.21	1.81	2.60	2.01	2.80	2.07	3.00	2.12	3.30	2.15	3.39	2.25
25	77	2.02	1.51	2.21	1.81	2.60	2.01	2.80	2.07	3.00	2.12	3.25	2.12	3.33	2.21
27	81	2.02	1.51	2.21	1.81	2.60	2.01	2.80	2.07	3.00	2.12	3.19	2.12	3.28	2.17
30	86	2.02	1.51	2.21	1.81	2.60	2.01	2.80	2.07	3.00	2.12	3.14	2.08	3.19	2.15
33	91	2.02	1.51	2.21	1.81	2.60	2.01	2.80	2.07	2.91	2.09	3.05	2.02	3.11	2.13
35	95	2.02	1.51	2.21	1.81	2.60	2.01	2.80	2.07	2.86	2.05	3.00	2.02	3.05	2.09
37	99	2.02	1.51	2.21	1.81	2.60	2.01	2.74	2.06	2.80	2.01	2.94	1.98	3.00	2.05
40	104	2.02	1.51	2.21	1.81	2.60	2.01	2.66	2.00	2.72	1.98	2.83	1.94	2.88	2.01
43	109	2.02	1.51	2.21	1.81	2.49	1.95	2.55	1.94	2.60	1.93	2.72	1.86	2.77	1.96

MODEL : AS12

Outdoor Temperature		Indoor Temperature													
		20°CDB/15°CWB		23°CDB/16°CWB		26°CDB/18°CWB		27°CDB/19°CWB		28°CDB/20°CWB		30°CDB/22°CWB		32°CDB/23°CWB	
		68°FDB/59°FWB		73°FDB/61°FWB		79°FDB/64°FWB		81°FDB/66°FWB		82°FDB/68°FWB		86°FDB/72°FWB		90°FDB/73°FWB	
(°CDB)	(°FDB)	TC	SHC	TC	SHC	TC	SHC	TC	SHC	TC	SHC	TC	SHC	TC	SHC
10	50	2.52	1.79	2.77	2.15	3.26	2.44	3.50	2.49	3.75	2.51	4.27	2.61	4.48	2.74
15	59	2.52	1.79	2.77	2.15	3.26	2.44	3.50	2.49	3.75	2.51	4.27	2.61	4.48	2.74
21	70	2.52	1.79	2.77	2.15	3.26	2.44	3.50	2.49	3.75	2.51	4.20	2.57	4.27	2.69
23	73	2.52	1.79	2.77	2.15	3.26	2.44	3.50	2.49	3.75	2.51	4.13	2.57	4.24	2.67
25	77	2.52	1.79	2.77	2.15	3.26	2.44	3.50	2.49	3.75	2.51	4.06	2.52	4.17	2.63
27	81	2.52	1.79	2.77	2.15	3.26	2.44	3.50	2.49	3.75	2.51	3.99	2.48	4.10	2.62
30	86	2.52	1.79	2.77	2.15	3.26	2.44	3.50	2.49	3.75	2.51	3.92	2.47	3.99	2.56
33	91	2.52	1.79	2.77	2.15	3.26	2.44	3.50	2.49	3.64	2.48	3.82	2.41	3.89	2.53
35	95	2.52	1.79	2.77	2.15	3.26	2.44	3.50	2.49	3.57	2.43	3.75	2.40	3.82	2.52
37	99	2.52	1.79	2.77	2.15	3.26	2.44	3.43	2.44	3.50	2.42	3.68	2.36	3.75	2.47
40	104	2.52	1.79	2.77	2.15	3.26	2.44	3.33	2.39	3.40	2.38	3.54	2.34	3.61	2.45
43	109	2.52	1.79	2.77	2.15	3.12	2.37	3.19	2.36	3.26	2.31	3.40	2.28	3.47	2.39

MODEL : AS14

Outdoor Temperature		Indoor Temperature													
		20°CDB/15°CWB		23°CDB/16°CWB		26°CDB/18°CWB		27°CDB/19°CWB		28°CDB/20°CWB		30°CDB/22°CWB		32°CDB/23°CWB	
		68°FDB/59°FWB		73°FDB/61°FWB		79°FDB/64°FWB		81°FDB/66°FWB		82°FDB/68°FWB		86°FDB/72°FWB		90°FDB/73°FWB	
(°CDB)	(°FDB)	TC	SHC	TC	SHC	TC	SHC	TC	SHC	TC	SHC	TC	SHC	TC	SHC
10	50	2.74	2.11	3.00	2.57	3.53	2.87	3.80	2.93	4.07	2.96	4.64	3.07	4.86	3.28
15	59	2.74	2.11	3.00	2.57	3.53	2.87	3.80	2.93	4.07	2.96	4.64	3.07	4.86	3.28
21	70	2.74	2.11	3.00	2.57	3.53	2.87	3.80	2.93	4.07	2.96	4.56	3.02	4.64	3.17
23	73	2.74	2.11	3.00	2.57	3.53	2.87	3.80	2.93	4.07	2.96	4.48	3.02	4.60	3.15
25	77	2.74	2.11	3.00	2.57	3.53	2.87	3.80	2.93	4.07	2.96	4.41	2.97	4.52	3.14
27	81	2.74	2.11	3.00	2.57	3.53	2.87	3.80	2.93	4.07	2.96	4.33	2.97	4.45	3.09
30	86	2.74	2.11	3.00	2.57	3.53	2.87	3.80	2.93	4.07	2.96	4.26	2.91	4.33	3.06
33	91	2.74	2.11	3.00	2.57	3.53	2.87	3.80	2.93	3.95	2.92	4.14	2.88	4.22	3.02
35	95	2.74	2.11	3.00	2.57	3.53	2.87	3.80	2.93	3.88	2.90	4.07	2.83	4.14	2.97
37	99	2.74	2.11	3.00	2.57	3.53	2.87	3.72	2.91	3.80	2.84	3.99	2.82	4.07	2.96
40	104	2.74	2.11	3.00	2.57	3.53	2.87	3.61	2.86	3.69	2.80	3.84	2.75	3.91	2.89
43	109	2.74	2.11	3.00	2.57	3.38	2.78	3.46	2.77	3.53	2.76	3.69	2.68	3.76	2.82

TC : Total Capacity kW
 SHC : Sensible Heat Capacity kW

The data is based on the following conditions. Pipe length : 7.5m ; Height difference : 0 m.

4-8-7. WALL MOUNTED TYPE

COOLING CAPACITY

MODEL : AS18

Outdoor Temperature		Indoor Temperature													
		20°CDB/15°CWB		23°CDB/16°CWB		26°CDB/18°CWB		27°CDB/19°CWB		28°CDB/20°CWB		30°CDB/22°CWB		32°CDB/23°CWB	
		68°FDB/59°FWB		73°FDB/61°FWB		79°FDB/64°FWB		81°FDB/66°FWB		82°FDB/68°FWB		86°FDB/72°FWB		90°FDB/73°FWB	
(°CDB)	(°FDB)	TC	SHC	TC	SHC	TC	SHC	TC	SHC	TC	SHC	TC	SHC	TC	SHC
10	50	3.89	2.80	4.27	3.40	5.02	3.86	5.40	3.89	5.78	3.94	6.59	4.04	6.91	4.30
15	59	3.89	2.80	4.27	3.40	5.02	3.86	5.40	3.89	5.78	3.94	6.59	4.04	6.91	4.30
21	70	3.89	2.80	4.27	3.40	5.02	3.86	5.40	3.89	5.78	3.94	6.48	4.04	6.59	4.23
23	73	3.89	2.80	4.27	3.40	5.02	3.86	5.40	3.89	5.78	3.94	6.37	3.97	6.53	4.20
25	77	3.89	2.80	4.27	3.40	5.02	3.86	5.40	3.89	5.78	3.94	6.26	3.96	6.43	4.13
27	81	3.89	2.80	4.27	3.40	5.02	3.86	5.40	3.89	5.78	3.94	6.16	3.89	6.32	4.12
30	86	3.89	2.80	4.27	3.40	5.02	3.86	5.40	3.89	5.78	3.94	6.05	3.88	6.16	4.07
33	91	3.89	2.80	4.27	3.40	5.02	3.86	5.40	3.89	5.62	3.88	5.89	3.78	5.99	3.97
35	95	3.89	2.80	4.27	3.40	5.02	3.86	5.40	3.89	5.51	3.86	5.78	3.77	5.89	3.95
37	99	3.89	2.80	4.27	3.40	5.02	3.86	5.29	3.81	5.40	3.78	5.67	3.70	5.78	3.94
40	104	3.89	2.80	4.27	3.40	5.02	3.86	5.13	3.74	5.24	3.72	5.45	3.66	5.56	3.84
43	109	3.89	2.80	4.27	3.40	4.81	3.69	4.91	3.68	5.02	3.71	5.24	3.57	5.35	3.75

MODEL : AS24

Outdoor Temperature		Indoor Temperature													
		20°CDB/15°CWB		23°CDB/16°CWB		26°CDB/18°CWB		27°CDB/19°CWB		28°CDB/20°CWB		30°CDB/22°CWB		32°CDB/23°CWB	
		68°FDB/59°FWB		73°FDB/61°FWB		79°FDB/64°FWB		81°FDB/66°FWB		82°FDB/68°FWB		86°FDB/72°FWB		90°FDB/73°FWB	
(°CDB)	(°FDB)	TC	SHC	TC	SHC	TC	SHC	TC	SHC	TC	SHC	TC	SHC	TC	SHC
10	50	4.97	3.53	5.45	4.24	6.42	4.74	6.90	4.90	7.38	4.96	8.42	5.09	8.83	5.42
15	59	4.97	3.53	5.45	4.24	6.42	4.74	6.90	4.90	7.38	4.96	8.42	5.09	8.83	5.42
21	70	4.97	3.53	5.45	4.24	6.42	4.74	6.90	4.90	7.38	4.96	8.28	5.00	8.42	5.25
23	73	4.97	3.53	5.45	4.24	6.42	4.74	6.90	4.90	7.38	4.96	8.14	5.00	8.35	5.21
25	77	4.97	3.53	5.45	4.24	6.42	4.74	6.90	4.90	7.38	4.96	8.00	4.91	8.21	5.20
27	81	4.97	3.53	5.45	4.24	6.42	4.74	6.90	4.90	7.38	4.96	7.87	4.91	8.07	5.11
30	86	4.97	3.53	5.45	4.24	6.42	4.74	6.90	4.90	7.38	4.96	7.73	4.82	7.87	5.06
33	91	4.97	3.53	5.45	4.24	6.42	4.74	6.90	4.90	7.18	4.82	7.52	4.76	7.66	5.00
35	95	4.97	3.53	5.45	4.24	6.42	4.74	6.90	4.90	7.04	4.79	7.38	4.68	7.52	4.98
37	99	4.97	3.53	5.45	4.24	6.42	4.74	6.76	4.80	6.90	4.77	7.25	4.66	7.38	4.89
40	104	4.97	3.53	5.45	4.24	6.42	4.74	6.56	4.78	6.69	4.69	6.97	4.55	7.11	4.77
43	109	4.97	3.53	5.45	4.24	6.14	4.65	6.28	4.64	6.42	4.68	6.69	4.50	6.83	4.72

MODEL : AS30

Outdoor Temperature		Indoor Temperature													
		20°CDB/15°CWB		23°CDB/16°CWB		26°CDB/18°CWB		27°CDB/19°CWB		28°CDB/20°CWB		30°CDB/22°CWB		32°CDB/23°CWB	
		68°FDB/59°FWB		73°FDB/61°FWB		79°FDB/64°FWB		81°FDB/66°FWB		82°FDB/68°FWB		86°FDB/72°FWB		90°FDB/73°FWB	
(°CDB)	(°FDB)	TC	SHC	TC	SHC	TC	SHC	TC	SHC	TC	SHC	TC	SHC	TC	SHC
10	50	5.76	4.09	6.32	4.93	7.44	5.58	8.00	5.68	8.56	5.74	9.76	5.95	10.2	6.35
15	59	5.76	4.09	6.32	4.93	7.44	5.58	8.00	5.68	8.56	5.74	9.76	5.95	10.2	6.35
21	70	5.76	4.09	6.32	4.93	7.44	5.58	8.00	5.68	8.56	5.74	9.60	5.86	9.76	6.15
23	73	5.76	4.09	6.32	4.93	7.44	5.58	8.00	5.68	8.56	5.74	9.44	5.85	9.68	6.10
25	77	5.76	4.09	6.32	4.93	7.44	5.58	8.00	5.68	8.56	5.74	9.28	5.75	9.52	6.00
27	81	5.76	4.09	6.32	4.93	7.44	5.58	8.00	5.68	8.56	5.74	9.12	5.75	9.36	5.99
30	86	5.76	4.09	6.32	4.93	7.44	5.58	8.00	5.68	8.56	5.74	8.96	5.64	9.12	5.93
33	91	5.76	4.09	6.32	4.93	7.44	5.58	8.00	5.68	8.32	5.66	8.72	5.58	8.88	5.77
35	95	5.76	4.09	6.32	4.93	7.44	5.58	8.00	5.68	8.16	5.63	8.56	5.48	8.72	5.76
37	99	5.76	4.09	6.32	4.93	7.44	5.58	7.84	5.57	8.00	5.52	8.40	5.46	8.56	5.65
40	104	5.76	4.09	6.32	4.93	7.44	5.58	7.60	5.47	7.76	5.43	8.08	5.33	8.24	5.60
43	109	5.76	4.09	6.32	4.93	7.12	5.41	7.28	5.39	7.44	5.28	7.76	5.20	7.92	5.46

TC : Total Capacity kW
 SHC : Sensible Heat Capacity kW

The data is based on the following conditions. Pipe length : 7.5m ; Height difference : 0 m.

4-9. CAPACITY TABLE (HEATING)

4-9-1. COMPACT DUCT TYPE (1 / 2)

■ MODEL : AR7

Outdoor Temperature			Indoor Temperature					
			15°CDB	18°CDB	20°CDB	23°CDB	25°CDB	27°CDB
(°CDB)	(°FDB)	RH	59°FDB	64°FDB	68°FDB	73°FDB	77°FDB	81°FDB
(°CDB)	(°FDB)	RH	TC	TC	TC	TC	TC	TC
-20	-4	RH85%	1.58	1.50	1.45	1.37	1.33	1.28
-15	5		1.83	1.76	1.70	1.62	1.58	1.54
-10	14		2.05	1.96	1.92	1.84	1.79	1.74
-5	23		2.29	2.20	2.16	2.07	1.96	1.76
0	32		2.52	2.44	2.39	2.16	1.96	1.76
5	41		2.71	2.64	2.45	2.16	1.96	1.76
7	45		2.81	2.64	2.45	2.16	1.96	1.76
10	50		2.81	2.64	2.45	2.16	1.96	1.76
15	59		2.94	2.64	2.45	2.16	1.96	1.76

■ MODEL : AR9

Outdoor Temperature			Indoor Temperature					
			15°CDB	18°CDB	20°CDB	23°CDB	25°CDB	27°CDB
(°CDB)	(°FDB)	RH	59°FDB	64°FDB	68°FDB	73°FDB	77°FDB	81°FDB
(°CDB)	(°FDB)	RH	TC	TC	TC	TC	TC	TC
-20	-4	RH85%	2.00	1.90	1.83	1.74	1.68	1.62
-15	5		2.32	2.22	2.15	2.06	2.00	1.94
-10	14		2.59	2.48	2.43	2.33	2.26	2.20
-5	23		2.90	2.78	2.73	2.61	2.48	2.22
0	32		3.19	3.08	3.03	2.73	2.48	2.22
5	41		3.43	3.34	3.10	2.73	2.48	2.22
7	45		3.55	3.34	3.10	2.73	2.48	2.22
10	50		3.55	3.34	3.10	2.73	2.48	2.22
15	59		3.72	3.34	3.10	2.73	2.48	2.22

■ MODEL : AR12

Outdoor Temperature			Indoor Temperature					
			15°CDB	18°CDB	20°CDB	23°CDB	25°CDB	27°CDB
(°CDB)	(°FDB)	RH	59°FDB	64°FDB	68°FDB	73°FDB	77°FDB	81°FDB
(°CDB)	(°FDB)	RH	TC	TC	TC	TC	TC	TC
-20	-4	RH85%	2.64	2.52	2.42	2.30	2.22	2.14
-15	5		3.06	2.94	2.84	2.72	2.64	2.57
-10	14		3.43	3.28	3.21	3.09	2.99	2.92
-5	23		3.83	3.68	3.61	3.46	3.28	2.94
0	32		4.22	4.08	4.00	3.61	3.28	2.94
5	41		4.54	4.42	4.10	3.61	3.28	2.94
7	45		4.69	4.42	4.10	3.61	3.28	2.94
10	50		4.69	4.42	4.10	3.61	3.28	2.94
15	59		4.92	4.42	4.10	3.61	3.28	2.94

TC : Total Capacity kW

The data is based on the following conditions. Pipe length : 7.5m ; Height difference : 0 m ; Static pressure : 0 Pa.

4-9-1. COMPACT DUCT TYPE (2 / 2)

HEATING CAPACITY

■ MODEL : AR14

Outdoor Temperature			Indoor Temperature					
			15°CDB	18°CDB	20°CDB	23°CDB	25°CDB	27°CDB
(°CDB)	(°FDB)	RH	59°FDB	64°FDB	68°FDB	73°FDB	77°FDB	81°FDB
(°CDB)	(°FDB)	RH	TC	TC	TC	TC	TC	TC
-20	-4	RH85%	3.10	2.95	2.84	2.69	2.60	2.51
-15	5		3.59	3.44	3.33	3.18	3.10	3.01
-10	14		4.02	3.84	3.76	3.61	3.50	3.41
-5	23		4.48	4.31	4.22	4.05	3.84	3.44
0	32		4.94	4.77	4.68	4.22	3.84	3.44
5	41		5.32	5.17	4.80	4.22	3.84	3.44
7	45		5.50	5.17	4.80	4.22	3.84	3.44
10	50		5.50	5.17	4.80	4.22	3.84	3.44
15	59		5.76	5.17	4.80	4.22	3.84	3.44

■ MODEL : AR18

Outdoor Temperature			Indoor Temperature					
			15°CDB	18°CDB	20°CDB	23°CDB	25°CDB	27°CDB
(°CDB)	(°FDB)	RH	59°FDB	64°FDB	68°FDB	73°FDB	77°FDB	81°FDB
(°CDB)	(°FDB)	RH	TC	TC	TC	TC	TC	TC
-20	-4	RH85%	3.61	3.44	3.31	3.14	3.04	2.93
-15	5		4.18	4.02	3.88	3.71	3.61	3.51
-10	14		4.69	4.49	4.38	4.22	4.08	3.98
-5	23		5.23	5.03	4.93	4.72	4.49	4.02
0	32		5.77	5.57	5.47	4.93	4.49	4.02
5	41		6.20	6.04	5.60	4.93	4.49	4.02
7	45		6.41	6.04	5.60	4.93	4.49	4.02
10	50		6.41	6.04	5.60	4.93	4.49	4.02
15	59		6.71	6.04	5.60	4.93	4.49	4.02

■ MODEL : AR22

Outdoor Temperature			Indoor Temperature					
			15°CDB	18°CDB	20°CDB	23°CDB	25°CDB	27°CDB
(°CDB)	(°FDB)	RH	59°FDB	64°FDB	68°FDB	73°FDB	77°FDB	81°FDB
(°CDB)	(°FDB)	RH	TC	TC	TC	TC	TC	TC
-20	-4	RH85%	4.06	3.87	3.72	3.53	3.41	3.29
-15	5		4.71	4.52	4.37	4.18	4.06	3.95
-10	14		5.27	5.05	4.93	4.74	4.59	4.48
-5	23		5.88	5.66	5.54	5.31	5.05	4.52
0	32		6.49	6.26	6.15	5.54	5.05	4.52
5	41		6.98	6.79	6.30	5.54	5.05	4.52
7	45		7.21	6.79	6.30	5.54	5.05	4.52
10	50		7.21	6.79	6.30	5.54	5.05	4.52
15	59		7.55	6.79	6.30	5.54	5.05	4.52

TC : Total Capacity kW

The data is based on the following conditions. Pipe length : 7.5m ; Height difference : 0 m ; Static pressure : 0 Pa.

4-9-2. LOW STATIC PRESSURE DUCT TYPE

HEATING CAPACITY

■ MODEL : ARXB25

Outdoor Temperature			Indoor Temperature					
			15°CDB	18°CDB	20°CDB	23°CDB	25°CDB	27°CDB
(°CDB)	(°FDB)	RH	59°FDB	64°FDB	68°FDB	73°FDB	77°FDB	81°FDB
(°CDB)	(°FDB)	RH	TC	TC	TC	TC	TC	TC
-20	-4	RH85%	5.06	4.82	4.64	4.40	4.25	4.11
-15	5		5.86	5.63	5.44	5.20	5.06	4.92
-10	14		6.57	6.29	6.15	5.91	5.72	5.58
-5	23		7.33	7.05	6.91	6.62	6.29	5.63
0	32		8.09	7.80	7.66	6.91	6.29	5.63
5	41		8.70	8.46	7.85	6.91	6.29	5.63
7	45		8.99	8.46	7.85	6.91	6.29	5.63
10	50		8.99	8.46	7.85	6.91	6.29	5.63
15	59		9.41	8.46	7.85	6.91	6.29	5.63

■ MODEL : ARXB30

Outdoor Temperature			Indoor Temperature					
			15°CDB	18°CDB	20°CDB	23°CDB	25°CDB	27°CDB
(°CDB)	(°FDB)	RH	59°FDB	64°FDB	68°FDB	73°FDB	77°FDB	81°FDB
(°CDB)	(°FDB)	RH	TC	TC	TC	TC	TC	TC
-20	-4	RH85%	5.87	5.59	5.38	5.10	4.93	4.76
-15	5		6.80	6.52	6.31	6.03	5.87	5.71
-10	14		7.62	7.29	7.13	6.85	6.63	6.47
-5	23		8.50	8.17	8.01	7.67	7.29	6.52
0	32		9.37	9.05	8.88	8.01	7.29	6.52
5	41		10.1	9.81	9.10	8.01	7.29	6.52
7	45		10.4	9.81	9.10	8.01	7.29	6.52
10	50		10.4	9.81	9.10	8.01	7.29	6.52
15	59		10.9	9.81	9.10	8.01	7.29	6.52

TC : Total Capacity kW

The data is based on the following conditions. Pipe length : 7.5m ; Height difference : 0 m ; Static pressure : 0 Pa.

INDOOR
UNIT

INDOOR
UNIT

4-9-3. DUCT TYPE

■ MODEL : AR25

Outdoor Temperature			Indoor Temperature					
			15°CDB	18°CDB	20°CDB	23°CDB	25°CDB	27°CDB
(°CDB)	(°FDB)	RH	59°FDB	64°FDB	68°FDB	73°FDB	77°FDB	81°FDB
(°CDB)	(°FDB)	RH	TC	TC	TC	TC	TC	TC
-20	-4	RH85%	5.06	4.82	4.64	4.40	4.25	4.11
-15	5		5.86	5.63	5.44	5.20	5.06	4.92
-10	14		6.57	6.29	6.15	5.91	5.72	5.58
-5	23		7.33	7.05	6.91	6.62	6.29	5.63
0	32		8.09	7.80	7.66	6.91	6.29	5.63
5	41		8.70	8.46	7.85	6.91	6.29	5.63
7	45		8.99	8.46	7.85	6.91	6.29	5.63
10	50		8.99	8.46	7.85	6.91	6.29	5.63
15	59	9.41	8.46	7.85	6.91	6.29	5.63	

■ MODEL : AR30

Outdoor Temperature			Indoor Temperature					
			15°CDB	18°CDB	20°CDB	23°CDB	25°CDB	27°CDB
(°CDB)	(°FDB)	RH	59°FDB	64°FDB	68°FDB	73°FDB	77°FDB	81°FDB
(°CDB)	(°FDB)	RH	TC	TC	TC	TC	TC	TC
-20	-4	RH85%	5.87	5.59	5.38	5.10	4.93	4.76
-15	5		6.80	6.52	6.31	6.03	5.87	5.71
-10	14		7.62	7.29	7.13	6.85	6.63	6.47
-5	23		8.50	8.17	8.01	7.67	7.29	6.52
0	32		9.37	9.05	8.88	8.01	7.29	6.52
5	41		10.1	9.81	9.10	8.01	7.29	6.52
7	45		10.4	9.81	9.10	8.01	7.29	6.52
10	50		10.4	9.81	9.10	8.01	7.29	6.52
15	59	10.9	9.81	9.10	8.01	7.29	6.52	

■ MODEL : AR36

Outdoor Temperature			Indoor Temperature					
			15°CDB	18°CDB	20°CDB	23°CDB	25°CDB	27°CDB
(°CDB)	(°FDB)	RH	59°FDB	64°FDB	68°FDB	73°FDB	77°FDB	81°FDB
(°CDB)	(°FDB)	RH	TC	TC	TC	TC	TC	TC
-20	-4	RH85%	6.90	6.57	6.32	5.99	5.80	5.60
-15	5		7.99	7.67	7.42	7.09	6.90	6.71
-10	14		8.96	8.57	8.38	8.06	7.80	7.61
-5	23		9.99	9.61	9.42	9.02	8.57	7.67
0	32		11.0	10.6	10.4	9.42	8.57	7.67
5	41		11.9	11.5	10.7	9.42	8.57	7.67
7	45		12.3	11.5	10.7	9.42	8.57	7.67
10	50		12.3	11.5	10.7	9.42	8.57	7.67
15	59	12.8	11.5	10.7	9.42	8.57	7.67	

■ MODEL : AR45

Outdoor Temperature			Indoor Temperature					
			15°CDB	18°CDB	20°CDB	23°CDB	25°CDB	27°CDB
(°CDB)	(°FDB)	RH	59°FDB	64°FDB	68°FDB	73°FDB	77°FDB	81°FDB
(°CDB)	(°FDB)	RH	TC	TC	TC	TC	TC	TC
-20	-4	RH85%	8.84	8.41	8.10	7.67	7.43	7.17
-15	5		10.2	9.82	9.49	9.08	8.84	8.59
-10	14		11.5	11.0	10.7	10.3	9.99	9.74
-5	23		12.8	12.3	12.1	11.5	11.0	9.82
0	32		14.1	13.6	13.4	12.1	11.0	9.82
5	41		15.2	14.8	13.7	12.1	11.0	9.82
7	45		15.7	14.8	13.7	12.1	11.0	9.82
10	50		15.7	14.8	13.7	12.1	11.0	9.82
15	59	16.4	14.8	13.7	12.1	11.0	9.82	

TC : Total Capacity kW

The data is based on the following conditions. Pipe length : 7.5m ; Height difference : 0 m ; Static pressure : 100 Pa.

4-9-4. COMPACT CASSETTE TYPE

HEATING CAPACITY

■ MODEL : AU7

Outdoor Temperature			Indoor Temperature					
			15°CDB	18°CDB	20°CDB	23°CDB	25°CDB	27°CDB
(°CDB)	(°FDB)	RH	59°FDB	64°FDB	68°FDB	73°FDB	77°FDB	81°FDB
(°CDB)	(°FDB)	RH	TC	TC	TC	TC	TC	TC
-20	-4	RH85%	1.58	1.50	1.45	1.37	1.33	1.28
-15	5		1.83	1.76	1.70	1.62	1.58	1.54
-10	14		2.05	1.96	1.92	1.84	1.79	1.74
-5	23		2.29	2.20	2.16	2.07	1.96	1.76
0	32		2.52	2.44	2.39	2.16	1.96	1.76
5	41		2.71	2.64	2.45	2.16	1.96	1.76
7	45		2.81	2.64	2.45	2.16	1.96	1.76
10	50		2.81	2.64	2.45	2.16	1.96	1.76
15	59		2.94	2.64	2.45	2.16	1.96	1.76

■ MODEL : AU9

Outdoor Temperature			Indoor Temperature					
			15°CDB	18°CDB	20°CDB	23°CDB	25°CDB	27°CDB
(°CDB)	(°FDB)	RH	59°FDB	64°FDB	68°FDB	73°FDB	77°FDB	81°FDB
(°CDB)	(°FDB)	RH	TC	TC	TC	TC	TC	TC
-20	-4	RH85%	2.00	1.90	1.83	1.74	1.68	1.62
-15	5		2.32	2.22	2.15	2.06	2.00	1.94
-10	14		2.59	2.48	2.43	2.33	2.26	2.20
-5	23		2.90	2.78	2.73	2.61	2.48	2.22
0	32		3.19	3.08	3.03	2.73	2.48	2.22
5	41		3.43	3.34	3.10	2.73	2.48	2.22
7	45		3.55	3.34	3.10	2.73	2.48	2.22
10	50		3.55	3.34	3.10	2.73	2.48	2.22
15	59		3.72	3.34	3.10	2.73	2.48	2.22

■ MODEL : AU12

Outdoor Temperature			Indoor Temperature					
			15°CDB	18°CDB	20°CDB	23°CDB	25°CDB	27°CDB
(°CDB)	(°FDB)	RH	59°FDB	64°FDB	68°FDB	73°FDB	77°FDB	81°FDB
(°CDB)	(°FDB)	RH	TC	TC	TC	TC	TC	TC
-20	-4	RH85%	2.64	2.52	2.42	2.30	2.22	2.14
-15	5		3.06	2.94	2.84	2.72	2.64	2.57
-10	14		3.43	3.28	3.21	3.09	2.99	2.92
-5	23		3.83	3.68	3.61	3.46	3.28	2.94
0	32		4.22	4.08	4.00	3.61	3.28	2.94
5	41		4.54	4.42	4.10	3.61	3.28	2.94
7	45		4.69	4.42	4.10	3.61	3.28	2.94
10	50		4.69	4.42	4.10	3.61	3.28	2.94
15	59		4.92	4.42	4.10	3.61	3.28	2.94

■ MODEL : AU14

Outdoor Temperature			Indoor Temperature					
			15°CDB	18°CDB	20°CDB	23°CDB	25°CDB	27°CDB
(°CDB)	(°FDB)	RH	59°FDB	64°FDB	68°FDB	73°FDB	77°FDB	81°FDB
(°CDB)	(°FDB)	RH	TC	TC	TC	TC	TC	TC
-20	-4	RH85%	2.90	2.76	2.66	2.52	2.44	2.35
-15	5		3.36	3.23	3.12	2.98	2.90	2.82
-10	14		3.77	3.60	3.52	3.39	3.28	3.20
-5	23		4.20	4.04	3.96	3.79	3.60	3.23
0	32		4.64	4.47	4.39	3.96	3.60	3.23
5	41		4.99	4.85	4.50	3.96	3.60	3.23
7	45		5.15	4.85	4.50	3.96	3.60	3.23
10	50		5.15	4.85	4.50	3.96	3.60	3.23
15	59		5.40	4.85	4.50	3.96	3.60	3.23

■ MODEL : AU18

Outdoor Temperature			Indoor Temperature					
			15°CDB	18°CDB	20°CDB	23°CDB	25°CDB	27°CDB
(°CDB)	(°FDB)	RH	59°FDB	64°FDB	68°FDB	73°FDB	77°FDB	81°FDB
(°CDB)	(°FDB)	RH	TC	TC	TC	TC	TC	TC
-20	-4	RH85%	3.52	3.35	3.22	3.05	2.95	2.85
-15	5		4.07	3.91	3.78	3.61	3.52	3.42
-10	14		4.56	4.37	4.27	4.10	3.97	3.87
-5	23		5.09	4.89	4.80	4.59	4.37	3.91
0	32		5.61	5.42	5.32	4.80	4.37	3.91
5	41		6.04	5.88	5.45	4.80	4.37	3.91
7	45		6.24	5.88	5.45	4.80	4.37	3.91
10	50		6.24	5.88	5.45	4.80	4.37	3.91
15	59		6.53	5.88	5.45	4.80	4.37	3.91

TC : Total Capacity kW

The data is based on the following conditions. Pipe length : 7.5m ; Height difference : 0 m.

4-9-5. CASSETTE TYPE (1/2)

HEATING CAPACITY

■ MODEL : AU20

Outdoor Temperature			Indoor Temperature					
			15°CDB	18°CDB	20°CDB	23°CDB	25°CDB	27°CDB
(°CDB)	(°FDB)	RH	59°FDB	64°FDB	68°FDB	73°FDB	77°FDB	81°FDB
(°CDB)	(°FDB)	RH	TC	TC	TC	TC	TC	TC
-20	-4	RH85%	3.74	3.56	3.43	3.25	3.14	3.03
-15	5		4.33	4.16	4.02	3.85	3.74	3.64
-10	14		4.85	4.65	4.54	4.37	4.23	4.12
-5	23		5.42	5.21	5.10	4.89	4.65	4.16
0	32		5.97	5.77	5.66	5.10	4.65	4.16
5	41		6.43	6.25	5.80	5.10	4.65	4.16
7	45		6.64	6.25	5.80	5.10	4.65	4.16
10	50		6.64	6.25	5.80	5.10	4.65	4.16
15	59		6.95	6.25	5.80	5.10	4.65	4.16

■ MODEL : AU25

Outdoor Temperature			Indoor Temperature					
			15°CDB	18°CDB	20°CDB	23°CDB	25°CDB	27°CDB
(°CDB)	(°FDB)	RH	59°FDB	64°FDB	68°FDB	73°FDB	77°FDB	81°FDB
(°CDB)	(°FDB)	RH	TC	TC	TC	TC	TC	TC
-20	-4	RH85%	5.06	4.82	4.64	4.40	4.25	4.11
-15	5		5.86	5.63	5.44	5.20	5.06	4.92
-10	14		6.57	6.29	6.15	5.91	5.72	5.58
-5	23		7.33	7.05	6.91	6.62	6.29	5.63
0	32		8.09	7.80	7.66	6.91	6.29	5.63
5	41		8.70	8.46	7.85	6.91	6.29	5.63
7	45		8.99	8.46	7.85	6.91	6.29	5.63
10	50		8.99	8.46	7.85	6.91	6.29	5.63
15	59		9.41	8.46	7.85	6.91	6.29	5.63

■ MODEL : AU30

Outdoor Temperature			Indoor Temperature					
			15°CDB	18°CDB	20°CDB	23°CDB	25°CDB	27°CDB
(°CDB)	(°FDB)	RH	59°FDB	64°FDB	68°FDB	73°FDB	77°FDB	81°FDB
(°CDB)	(°FDB)	RH	TC	TC	TC	TC	TC	TC
-20	-4	RH85%	5.87	5.59	5.38	5.10	4.93	4.76
-15	5		6.80	6.52	6.31	6.03	5.87	5.71
-10	14		7.62	7.29	7.13	6.85	6.63	6.47
-5	23		8.50	8.17	8.01	7.67	7.29	6.52
0	32		9.37	9.05	8.88	8.01	7.29	6.52
5	41		10.1	9.81	9.10	8.01	7.29	6.52
7	45		10.4	9.81	9.10	8.01	7.29	6.52
10	50		10.4	9.81	9.10	8.01	7.29	6.52
15	59		10.9	9.81	9.10	8.01	7.29	6.52

■ MODEL : AU36

Outdoor Temperature			Indoor Temperature					
			15°CDB	18°CDB	20°CDB	23°CDB	25°CDB	27°CDB
(°CDB)	(°FDB)	RH	59°FDB	64°FDB	68°FDB	73°FDB	77°FDB	81°FDB
(°CDB)	(°FDB)	RH	TC	TC	TC	TC	TC	TC
-20	-4	RH85%	6.90	6.57	6.32	5.99	5.80	5.60
-15	5		7.99	7.67	7.42	7.09	6.90	6.71
-10	14		8.96	8.57	8.38	8.06	7.80	7.61
-5	23		9.99	9.61	9.42	9.02	8.57	7.67
0	32		11.0	10.6	10.4	9.42	8.57	7.67
5	41		11.9	11.5	10.7	9.42	8.57	7.67
7	45		12.3	11.5	10.7	9.42	8.57	7.67
10	50		12.3	11.5	10.7	9.42	8.57	7.67
15	59		12.8	11.5	10.7	9.42	8.57	7.67

TC : Total Capacity kW

The data is based on the following conditions. Pipe length : 7.5m ; Height difference : 0 m.

4-9-5. CASSETTE TYPE (2/2)

HEATING CAPACITY

■ MODEL : AU45

Outdoor Temperature			Indoor Temperature					
			15°CDB	18°CDB	20°CDB	23°CDB	25°CDB	27°CDB
(°CDB)	(°FDB)	RH	59°FDB	64°FDB	68°FDB	73°FDB	77°FDB	81°FDB
(°CDB)	(°FDB)	RH	TC	TC	TC	TC	TC	TC
-20	-4	RH85%	8.84	8.41	8.10	7.67	7.43	7.17
-15	5		10.2	9.82	9.49	9.08	8.84	8.59
-10	14		11.5	11.0	10.7	10.3	9.99	9.74
-5	23		12.8	12.3	12.1	11.5	11.0	9.82
0	32		14.1	13.6	13.4	12.1	11.0	9.82
5	41		15.2	14.8	13.7	12.1	11.0	9.82
7	45		15.7	14.8	13.7	12.1	11.0	9.82
10	50		15.7	14.8	13.7	12.1	11.0	9.82
15	59		16.4	14.8	13.7	12.1	11.0	9.82

■ MODEL : AU54

Outdoor Temperature			Indoor Temperature					
			15°CDB	18°CDB	20°CDB	23°CDB	25°CDB	27°CDB
(°CDB)	(°FDB)	RH	59°FDB	64°FDB	68°FDB	73°FDB	77°FDB	81°FDB
(°CDB)	(°FDB)	RH	TC	TC	TC	TC	TC	TC
-20	-4	RH85%	10.2	9.70	9.34	8.85	8.56	8.26
-15	5		11.8	11.3	10.9	10.5	10.2	9.91
-10	14		13.2	12.7	12.4	11.9	11.5	11.2
-5	23		14.8	14.2	13.9	13.3	12.7	11.3
0	32		16.3	15.7	15.4	13.9	12.7	11.3
5	41		17.5	17.0	15.8	13.9	12.7	11.3
7	45		18.1	17.0	15.8	13.9	12.7	11.3
10	50		18.1	17.0	15.8	13.9	12.7	11.3
15	59		18.9	17.0	15.8	13.9	12.7	11.3

TC : Total Capacity kW

The data is based on the following conditions. Pipe length : 7.5m ; Height difference : 0 m.

INDOOR
UNIT

INDOOR
UNIT

4-9-6. COMPACT WALL MOUNTED TYPE

HEATING CAPACITY

■ MODEL : AS7

Outdoor Temperature			Indoor Temperature					
			15°CDB	18°CDB	20°CDB	23°CDB	25°CDB	27°CDB
(°CDB)	(°FDB)	RH	59°FDB	64°FDB	68°FDB	73°FDB	77°FDB	81°FDB
(°CDB)	(°FDB)	RH	TC	TC	TC	TC	TC	TC
-20	-4	RH85%	1.58	1.50	1.45	1.37	1.33	1.28
-15	5		1.83	1.76	1.70	1.62	1.58	1.54
-10	14		2.05	1.96	1.92	1.84	1.79	1.74
-5	23		2.29	2.20	2.16	2.07	1.96	1.76
0	32		2.52	2.44	2.39	2.16	1.96	1.76
5	41		2.71	2.64	2.45	2.16	1.96	1.76
7	45		2.81	2.64	2.45	2.16	1.96	1.76
10	50		2.81	2.64	2.45	2.16	1.96	1.76
15	59		2.94	2.64	2.45	2.16	1.96	1.76

■ MODEL : AS9

Outdoor Temperature			Indoor Temperature					
			15°CDB	18°CDB	20°CDB	23°CDB	25°CDB	27°CDB
(°CDB)	(°FDB)	RH	59°FDB	64°FDB	68°FDB	73°FDB	77°FDB	81°FDB
(°CDB)	(°FDB)	RH	TC	TC	TC	TC	TC	TC
-20	-4	RH85%	2.00	1.90	1.83	1.74	1.68	1.62
-15	5		2.32	2.22	2.15	2.06	2.00	1.94
-10	14		2.59	2.48	2.43	2.33	2.26	2.20
-5	23		2.90	2.78	2.73	2.61	2.48	2.22
0	32		3.19	3.08	3.03	2.73	2.48	2.22
5	41		3.43	3.34	3.10	2.73	2.48	2.22
7	45		3.55	3.34	3.10	2.73	2.48	2.22
10	50		3.55	3.34	3.10	2.73	2.48	2.22
15	59		3.72	3.34	3.10	2.73	2.48	2.22

■ MODEL : AS12

Outdoor Temperature			Indoor Temperature					
			15°CDB	18°CDB	20°CDB	23°CDB	25°CDB	27°CDB
(°CDB)	(°FDB)	RH	59°FDB	64°FDB	68°FDB	73°FDB	77°FDB	81°FDB
(°CDB)	(°FDB)	RH	TC	TC	TC	TC	TC	TC
-20	-4	RH85%	2.64	2.52	2.42	2.30	2.22	2.14
-15	5		3.06	2.94	2.84	2.72	2.64	2.57
-10	14		3.43	3.28	3.21	3.09	2.99	2.92
-5	23		3.83	3.68	3.61	3.46	3.28	2.94
0	32		4.22	4.08	4.00	3.61	3.28	2.94
5	41		4.54	4.42	4.10	3.61	3.28	2.94
7	45		4.69	4.42	4.10	3.61	3.28	2.94
10	50		4.69	4.42	4.10	3.61	3.28	2.94
15	59		4.92	4.42	4.10	3.61	3.28	2.94

■ MODEL : AS14

Outdoor Temperature			Indoor Temperature					
			15°CDB	18°CDB	20°CDB	23°CDB	25°CDB	27°CDB
(°CDB)	(°FDB)	RH	59°FDB	64°FDB	68°FDB	73°FDB	77°FDB	81°FDB
(°CDB)	(°FDB)	RH	TC	TC	TC	TC	TC	TC
-20	-4	RH85%	2.90	2.76	2.66	2.52	2.44	2.35
-15	5		3.36	3.23	3.12	2.98	2.90	2.82
-10	14		3.77	3.60	3.52	3.39	3.28	3.20
-5	23		4.20	4.04	3.96	3.79	3.60	3.23
0	32		4.64	4.47	4.39	3.96	3.60	3.23
5	41		4.99	4.85	4.50	3.96	3.60	3.23
7	45		5.15	4.85	4.50	3.96	3.60	3.23
10	50		5.15	4.85	4.50	3.96	3.60	3.23
15	59		5.40	4.85	4.50	3.96	3.60	3.23

TC : Total Capacity kW

The data is based on the following conditions. Pipe length : 7.5m ; Height difference : 0 m.

4-9-7. WALL MOUNTED TYPE

HEATING CAPACITY

■ MODEL : AS18

Outdoor Temperature			Indoor Temperature					
			15°CDB	18°CDB	20°CDB	23°CDB	25°CDB	27°CDB
(°CDB)	(°FDB)	RH	59°FDB	64°FDB	68°FDB	73°FDB	77°FDB	81°FDB
-20	-4	RH85%	TC	TC	TC	TC	TC	TC
-20	-4		3.61	3.44	3.31	3.14	3.04	2.93
-15	5		4.18	4.02	3.88	3.71	3.61	3.51
-10	14		4.69	4.49	4.38	4.22	4.08	3.98
-5	23		5.23	5.03	4.93	4.72	4.49	4.02
0	32		5.77	5.57	5.47	4.93	4.49	4.02
5	41		6.20	6.04	5.60	4.93	4.49	4.02
7	45		6.41	6.04	5.60	4.93	4.49	4.02
10	50		6.41	6.04	5.60	4.93	4.49	4.02
15	59		6.71	6.04	5.60	4.93	4.49	4.02

■ MODEL : AS24

Outdoor Temperature			Indoor Temperature					
			15°CDB	18°CDB	20°CDB	23°CDB	25°CDB	27°CDB
(°CDB)	(°FDB)	RH	59°FDB	64°FDB	68°FDB	73°FDB	77°FDB	81°FDB
-20	-4	RH85%	TC	TC	TC	TC	TC	TC
-20	-4		5.03	4.79	4.61	4.37	4.23	4.08
-15	5		5.83	5.59	5.41	5.17	5.03	4.89
-10	14		6.53	6.25	6.11	5.87	5.69	5.55
-5	23		7.29	7.00	6.86	6.58	6.25	5.59
0	32		8.03	7.75	7.61	6.86	6.25	5.59
5	41		8.64	8.41	7.80	6.86	6.25	5.59
7	45		8.93	8.41	7.80	6.86	6.25	5.59
10	50		8.93	8.41	7.80	6.86	6.25	5.59
15	59		9.35	8.41	7.80	6.86	6.25	5.59

■ MODEL : AS30

Outdoor Temperature			Indoor Temperature					
			15°CDB	18°CDB	20°CDB	23°CDB	25°CDB	27°CDB
(°CDB)	(°FDB)	RH	59°FDB	64°FDB	68°FDB	73°FDB	77°FDB	81°FDB
-20	-4	RH85%	TC	TC	TC	TC	TC	TC
-20	-4		5.68	5.40	5.20	4.93	4.77	4.60
-15	5		6.57	6.31	6.10	5.83	5.68	5.52
-10	14		7.37	7.05	6.89	6.63	6.42	6.26
-5	23		8.22	7.90	7.74	7.42	7.05	6.31
0	32		9.06	8.75	8.59	7.74	7.05	6.31
5	41		9.75	9.49	8.80	7.74	7.05	6.31
7	45		10.1	9.49	8.80	7.74	7.05	6.31
10	50		10.1	9.49	8.80	7.74	7.05	6.31
15	59		10.6	9.49	8.80	7.74	7.05	6.31

TC : Total Capacity kW

The data is based on the following conditions. Pipe length : 7.5m ; Height difference : 0 m.

4-10. AIR VELOCITY DISTRIBUTION

4-10-1. COMPACT CASSETTE TYPE

MODELS : AU7, AU9

Conditions
 Fan speed : High
 Operation mode : Fan
 Voltage : 240V

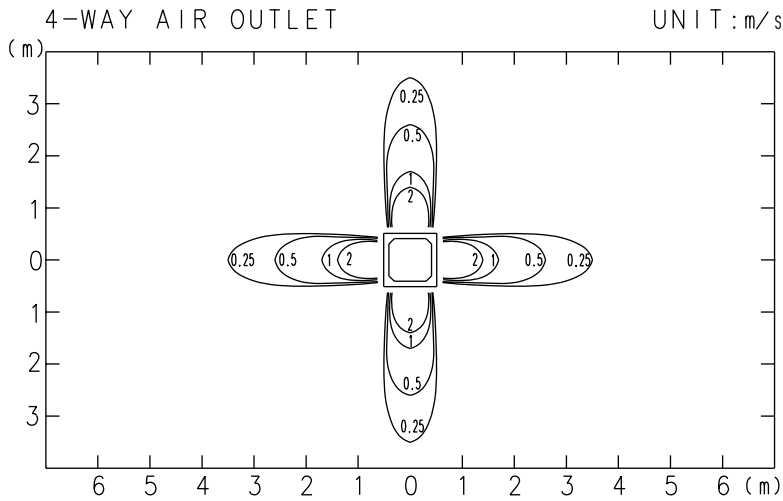

Fig TOP VIEW
 HORIZONTAL LOUVER : Upward

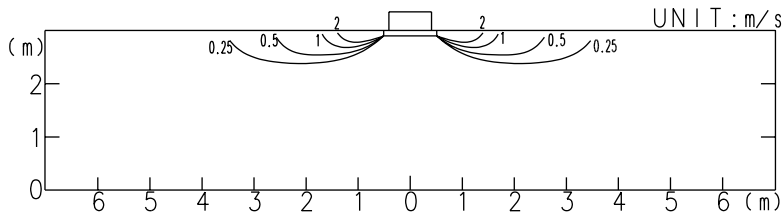

Fig SIDE VIEW
 HORIZONTAL LOUVER : Upward

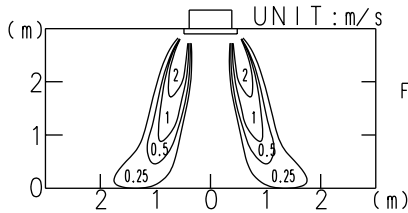

Fig SIDE VIEW
 HORIZONTAL LOUVER : Downward

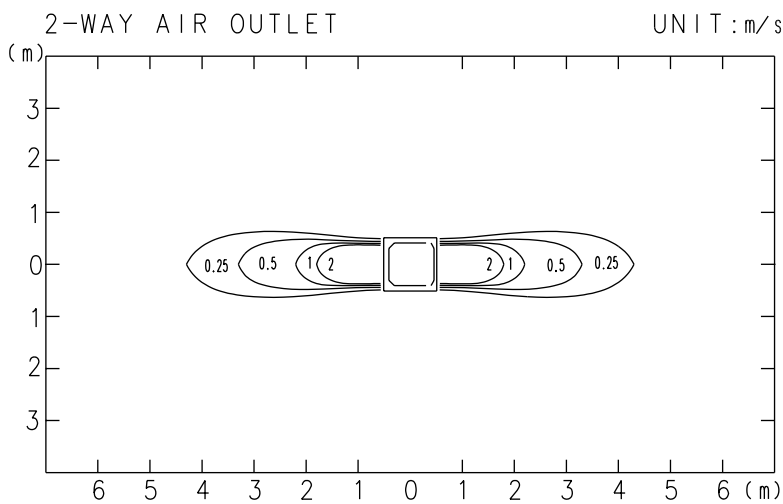

Fig TOP VIEW
 HORIZONTAL LOUVER : Upward

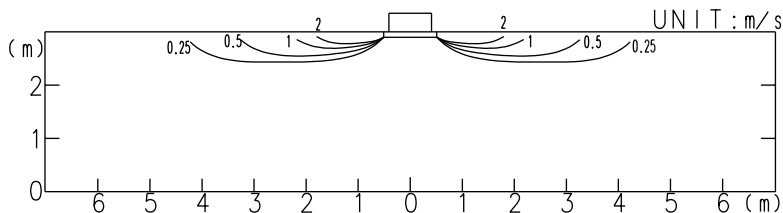

Fig SIDE VIEW
 HORIZONTAL LOUVER : Upward

INDOOR UNIT

INDOOR UNIT

MODELS : AU12 , AU14

Conditions
 Fan speed : High
 Operation mode : Fan
 Voltage : 240V

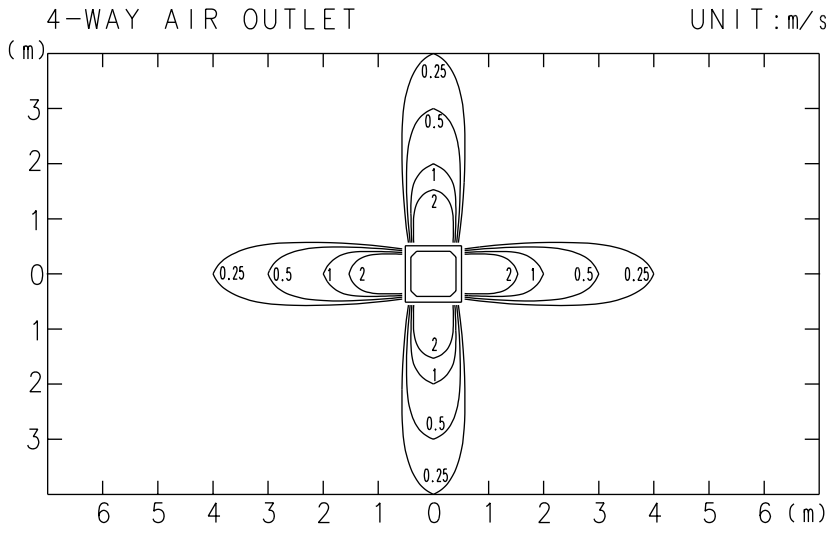

Fig
 TOP VIEW
 HORIZONTAL LOUVER
 : Upward

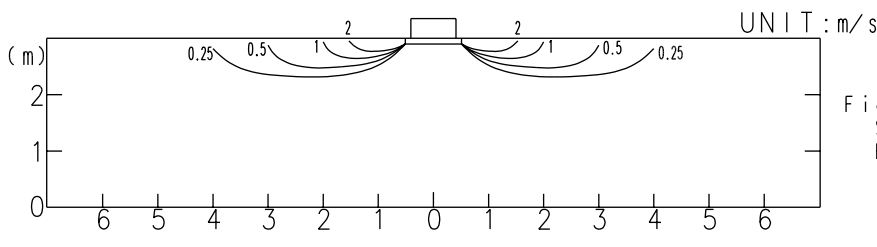

Fig
 SIDE VIEW
 HORIZONTAL LOUVER
 : Upward

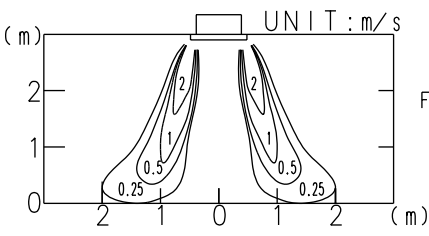

Fig
 SIDE VIEW
 HORIZONTAL LOUVER
 : Downward

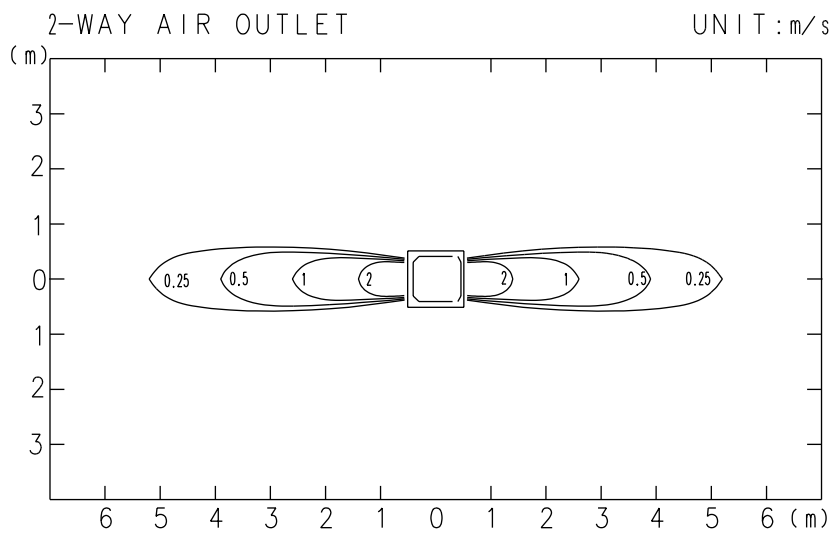
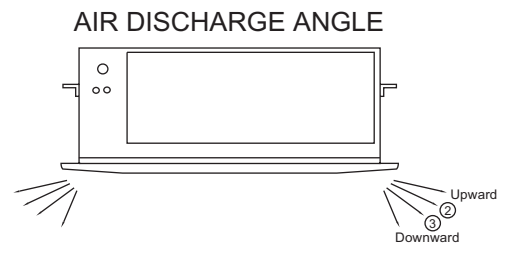

Fig
 TOP VIEW
 HORIZONTAL LOUVER
 : Upward

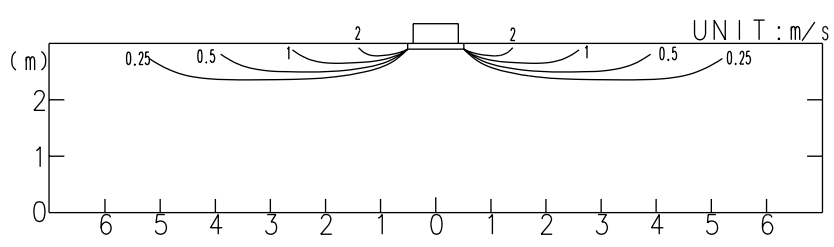

Fig
 SIDE VIEW
 HORIZONTAL LOUVER
 : Upward

INDOOR UNIT

INDOOR UNIT

MODEL : AU18

Conditions	
Fan speed	: High
Operation mode	: Fan
Voltage	: 240V

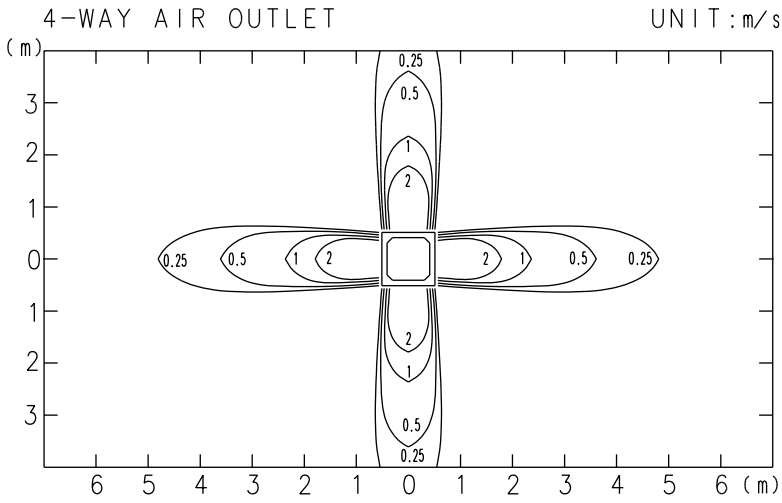

Fig TOP VIEW
HORIZONTAL LOUVER
: Upward

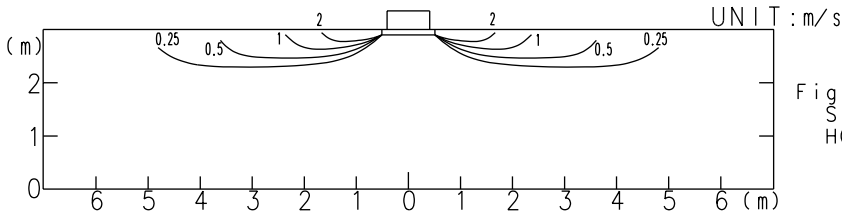

Fig SIDE VIEW
HORIZONTAL LOUVER
: Upward

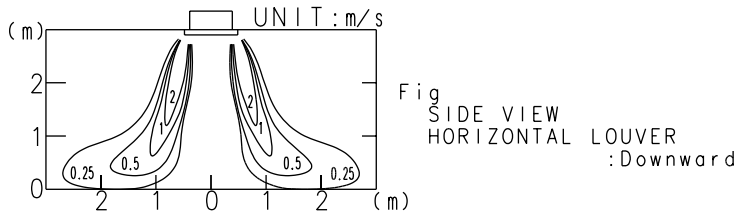

Fig SIDE VIEW
HORIZONTAL LOUVER
: Downward

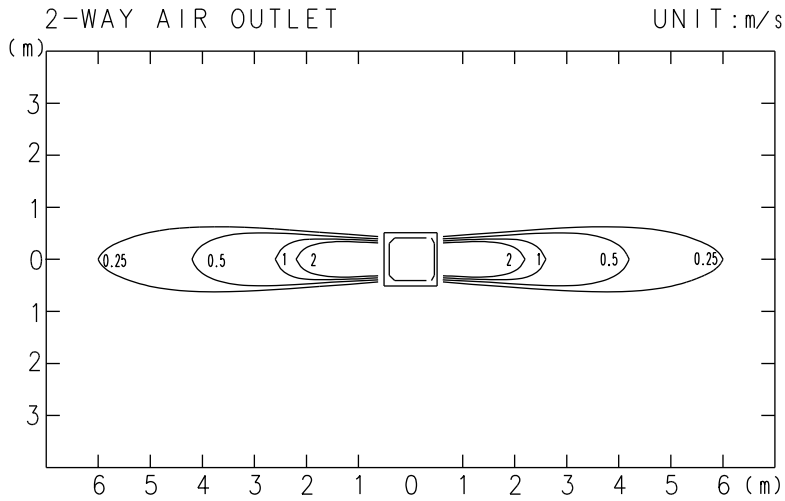
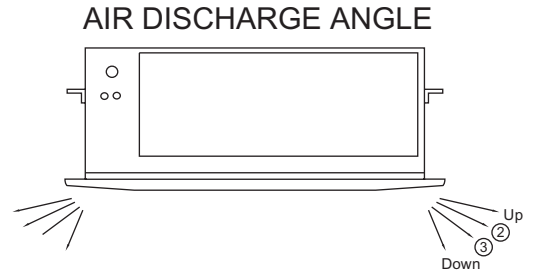

Fig TOP VIEW
HORIZONTAL LOUVER
: Upward

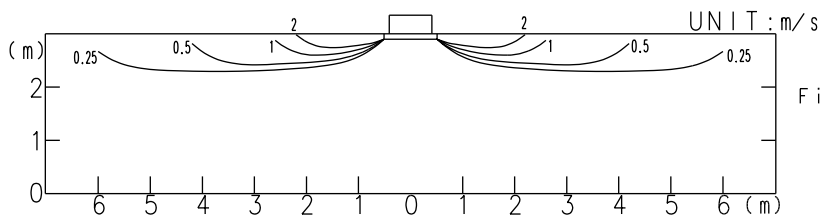

Fig SIDE VIEW
HORIZONTAL LOUVER
: Upward

INDOOR UNIT

INDOOR UNIT

4-10-2. CASSETTE TYPE

■ MODEL : AU20

Conditions	
Fan speed	: High
Operation mode	: Fan
Voltage	: 240V

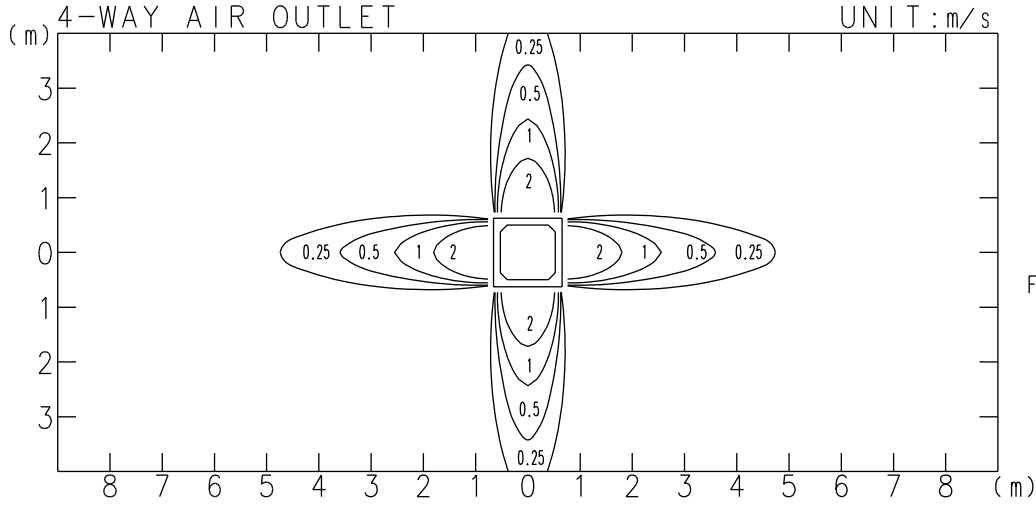

Fig
TOP VIEW
HORIZONTAL LOUVER
: Upward

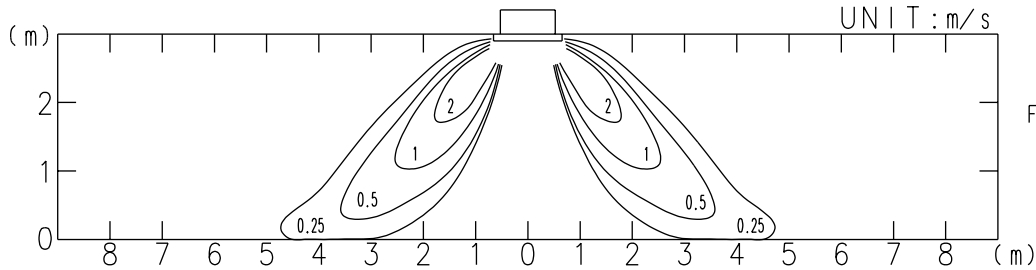

Fig
SIDE VIEW
HORIZONTAL LOUVER
: Upward

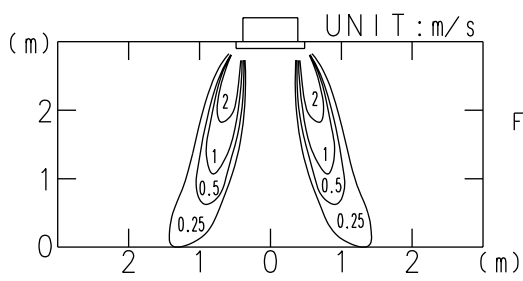

Fig
SIDE VIEW
HORIZONTAL LOUVER
: Downward

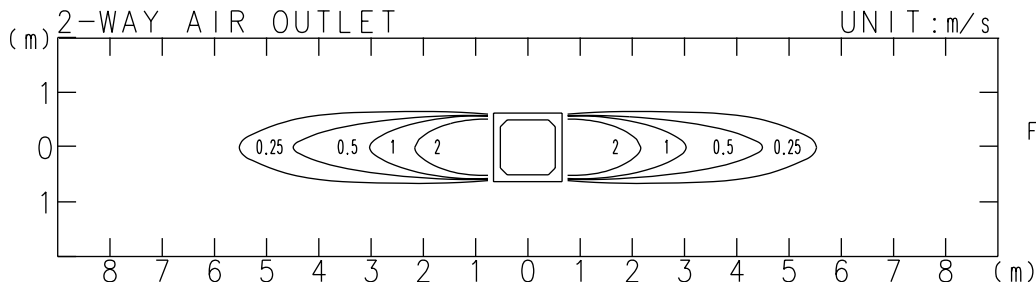

Fig
SIDE VIEW
HORIZONTAL LOUVER
: Upward

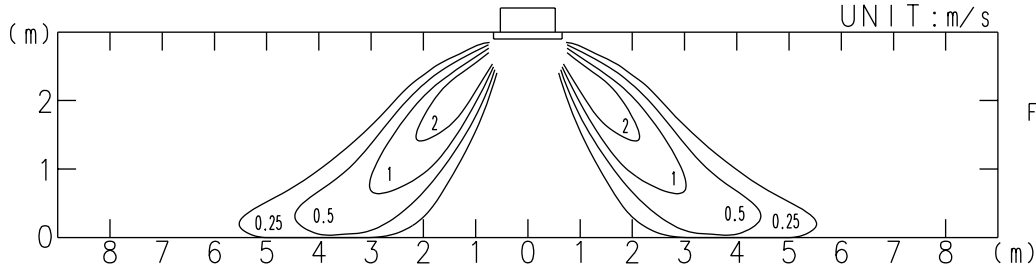

Fig
SIDE VIEW
HORIZONTAL LOUVER
: Upward

INDOOR UNIT

INDOOR UNIT

■ MODEL : AU25

Conditions
 Fan speed : High
 Operation mode : Fan
 Voltage : 240V

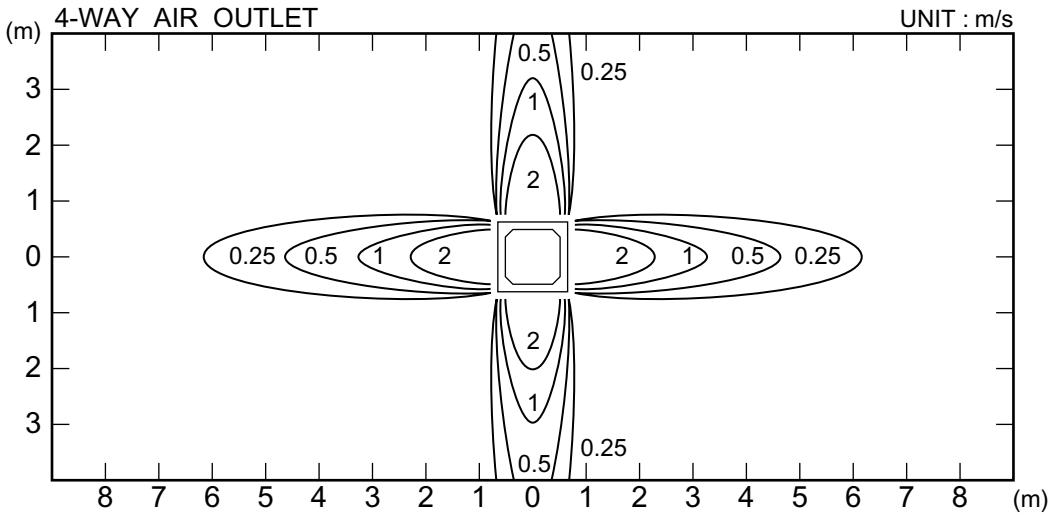

TOP VIEW
 AIR FLOW DIRECTION : Upward

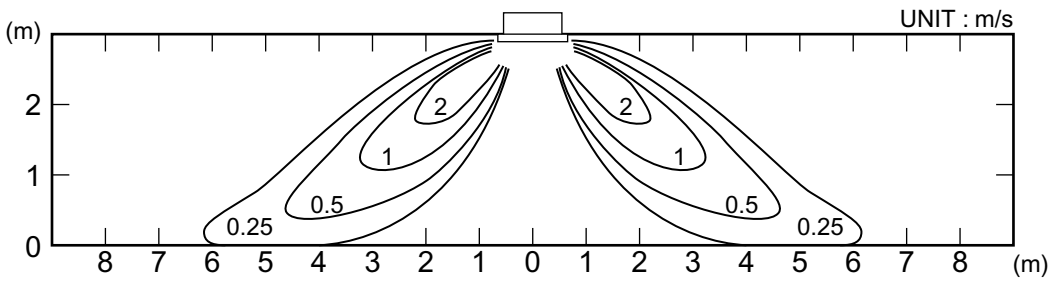

SIDE VIEW
 AIR FLOW DIRECTION : Upward

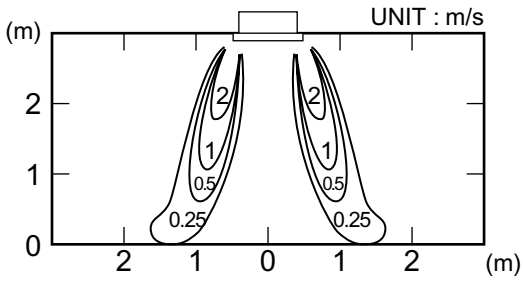

SIDE VIEW
 HORIZONTAL LOUVER
 : Downward

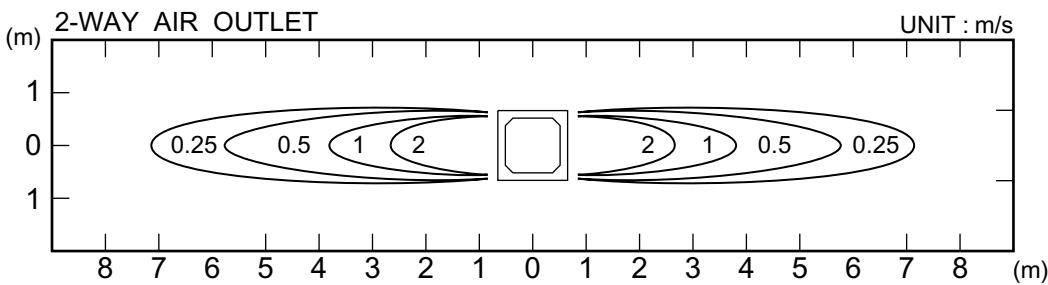

TOP VIEW
 AIR FLOW DIRECTION : Upward

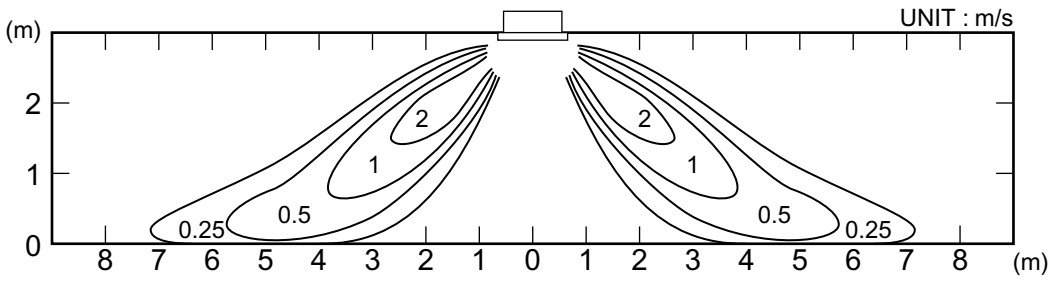

SIDE VIEW
 AIR FLOW DIRECTION : Upward

INDOOR UNIT

INDOOR UNIT

■ MODEL : AU30

Conditions
 Fan speed : High
 Operation mode : Fan
 Voltage : 240V

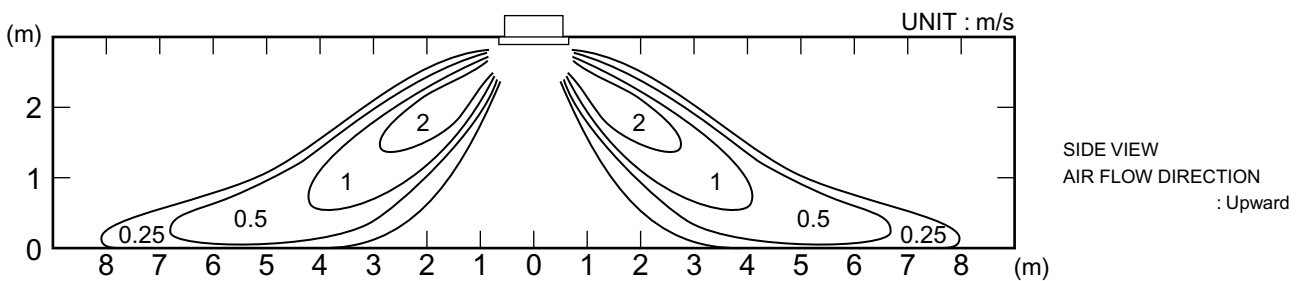
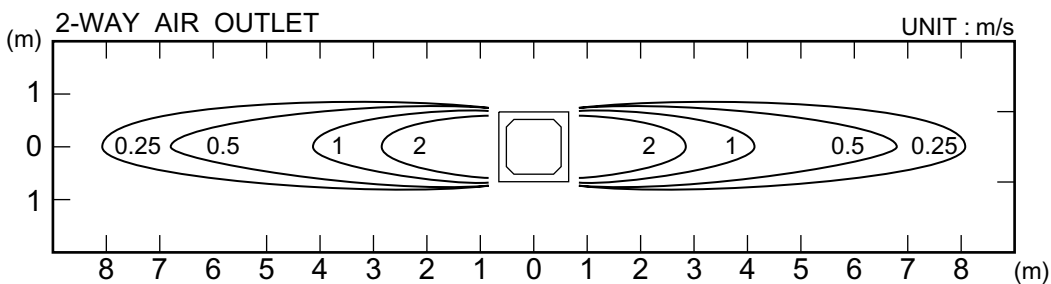
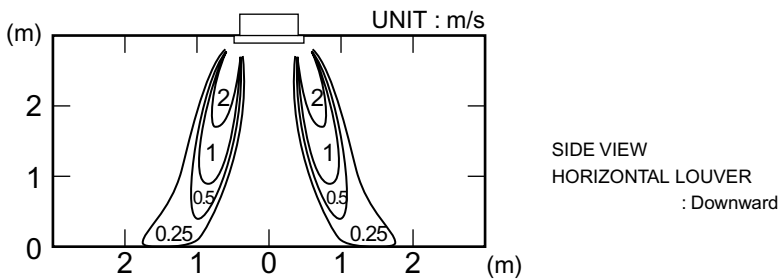
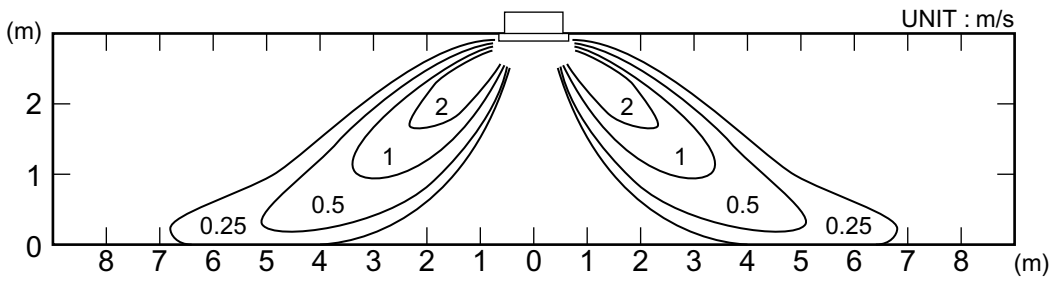
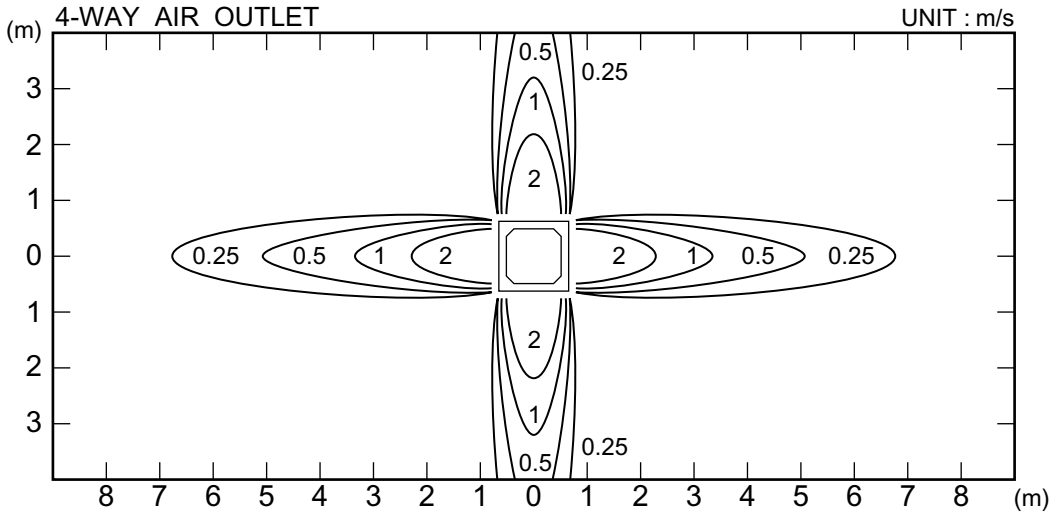

INDOOR UNIT

INDOOR UNIT

MODEL : AU36

Conditions	
Fan speed	: High
Operation mode	: Fan
Voltage	: 240V

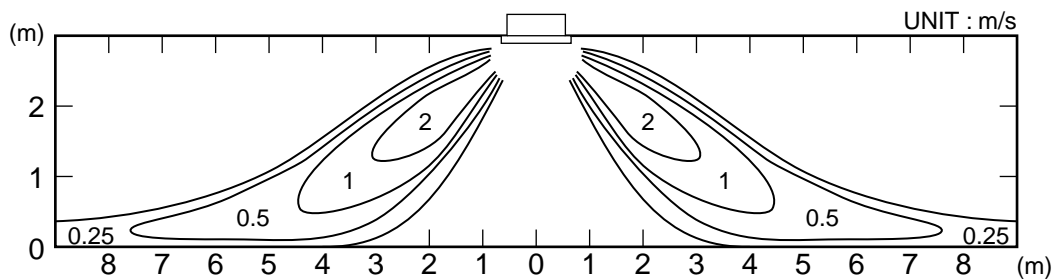
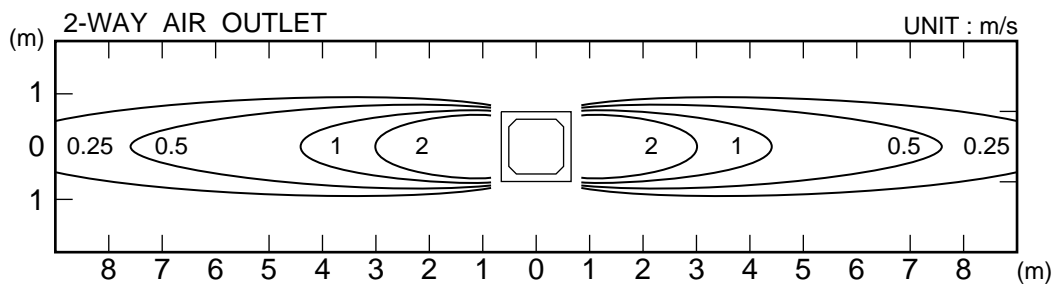
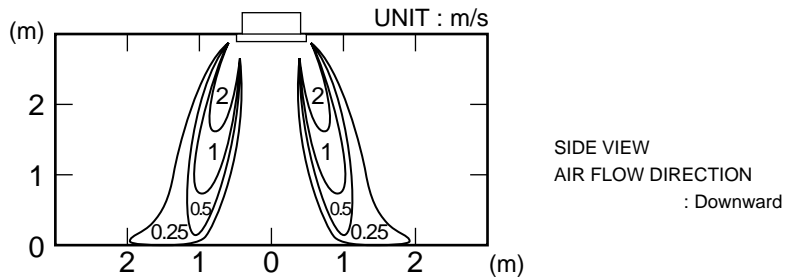
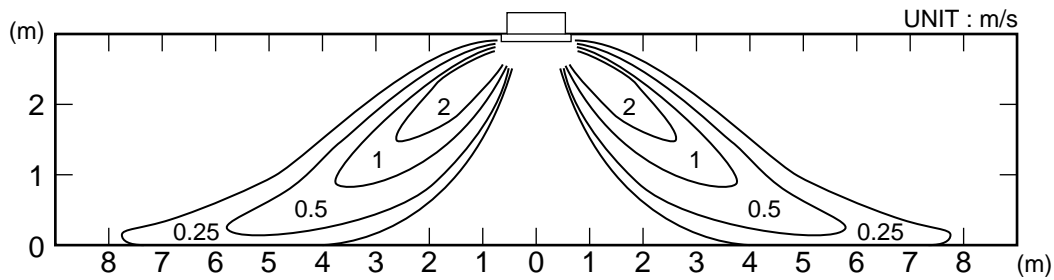
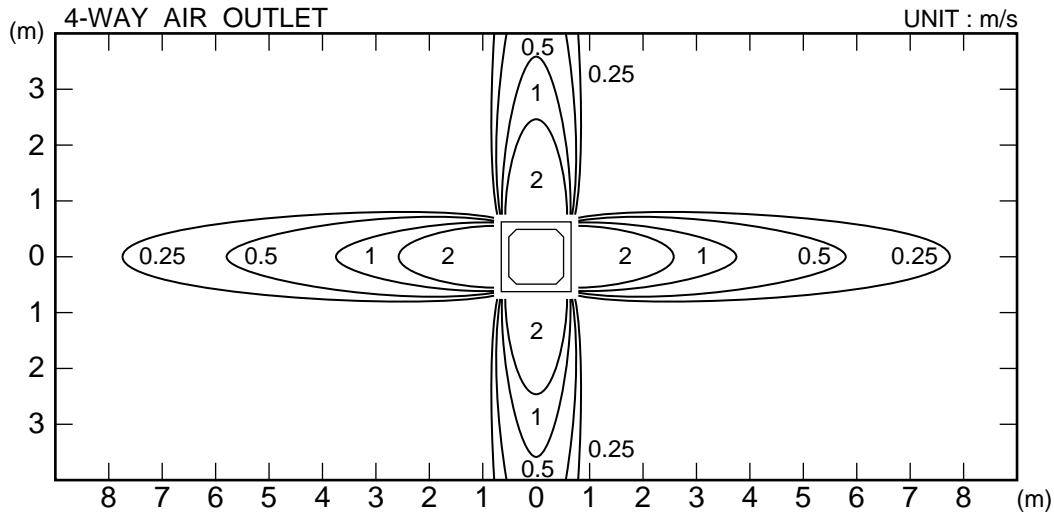

INDOOR UNIT

INDOOR UNIT

MODEL : AU45

Conditions	
Fan speed	: High
Operation mode	: Fan
Voltage	: 240V

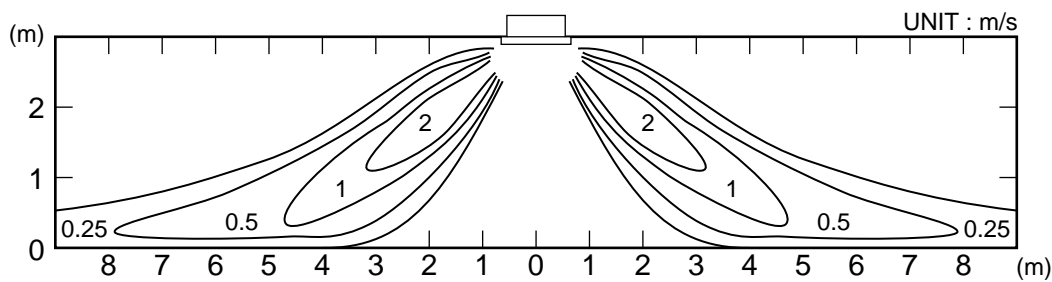
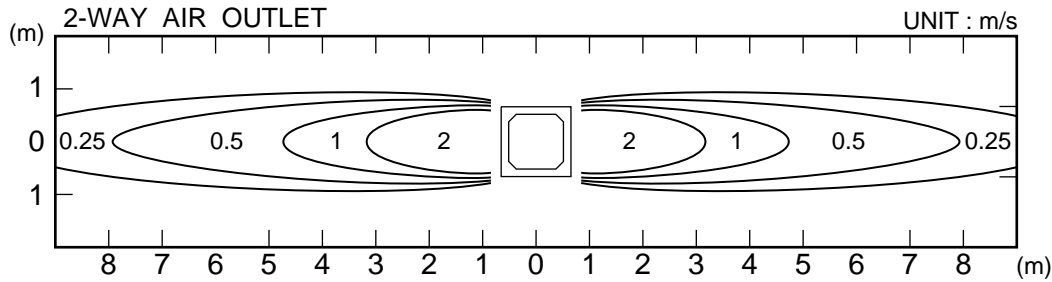
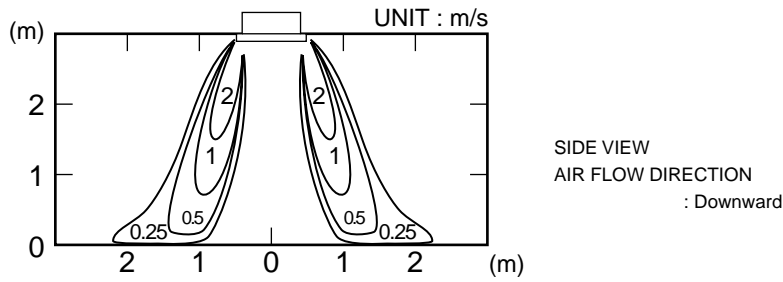
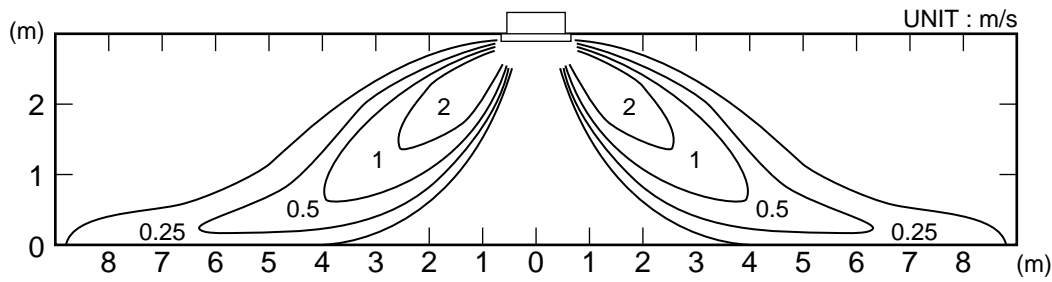
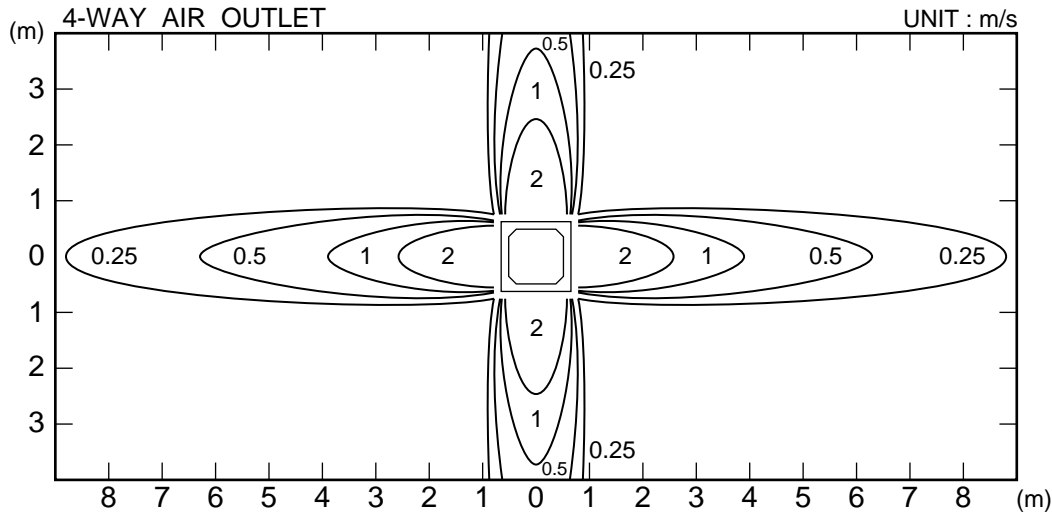

INDOOR UNIT

INDOOR UNIT

MODEL : AU54

Conditions	
Fan speed	: High
Operation mode	: Fan
Voltage	: 240V

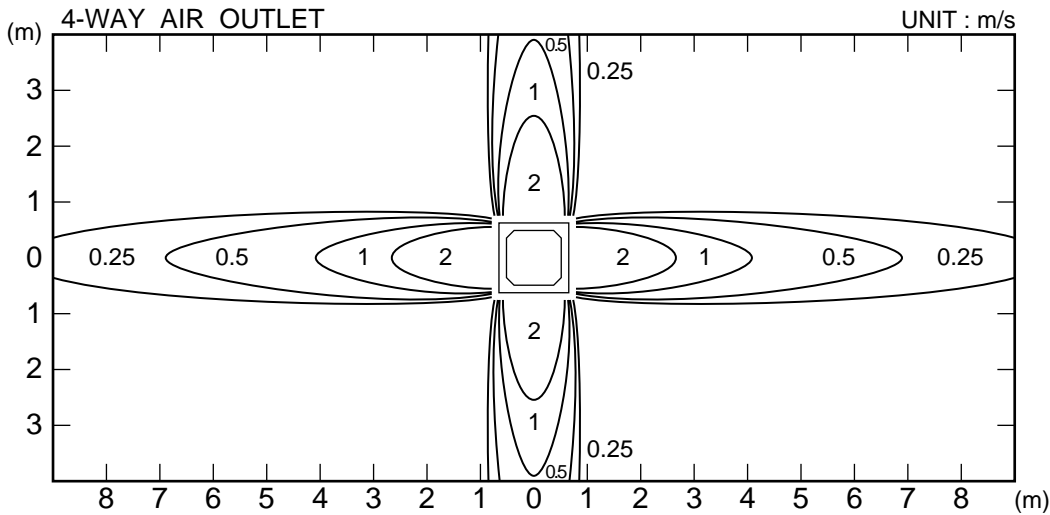

TOP VIEW
AIR FLOW DIRECTION : Upward

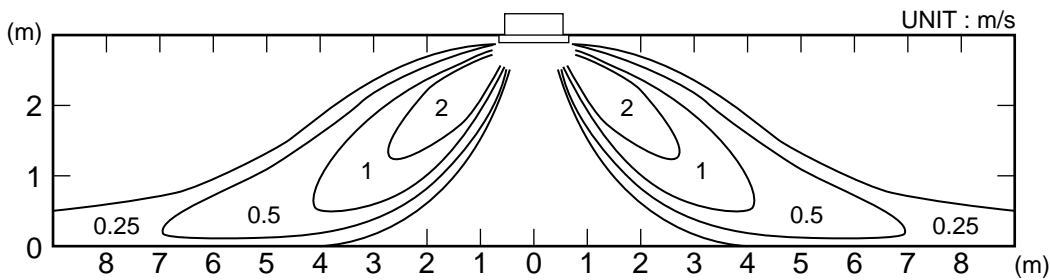

SIDE VIEW
AIR FLOW DIRECTION : Upward

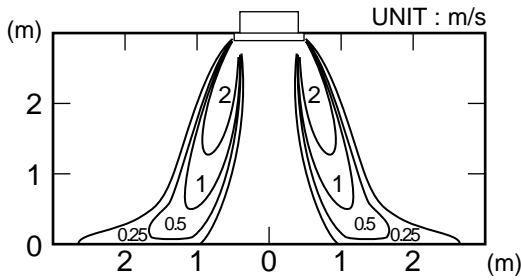

SIDE VIEW
AIR FLOW DIRECTION : Downward

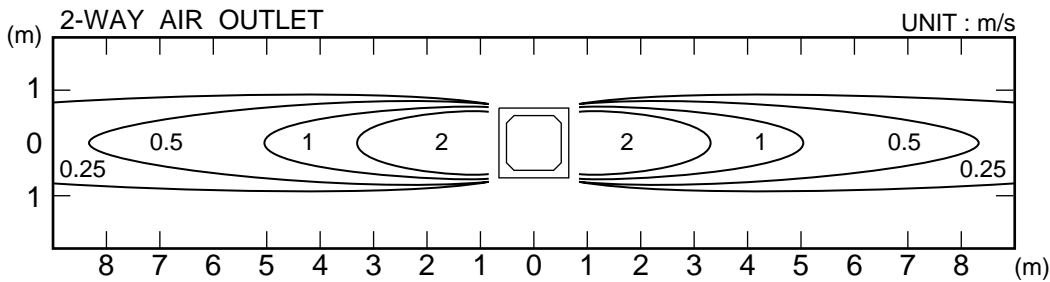

TOP VIEW
AIR FLOW DIRECTION : Upward

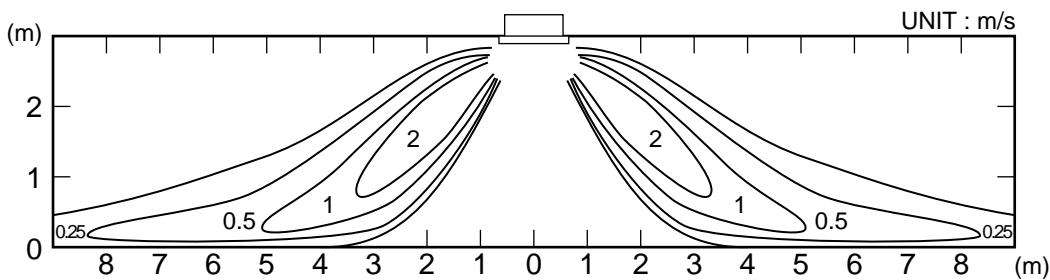

SIDE VIEW
AIR FLOW DIRECTION : Upward

INDOOR UNIT

INDOOR UNIT

4-10-3. COMPACT WALL MOUNTED TYPE

■ MODEL : AS7

Conditions	
Fan speed	: High
Operation mode	: Fan
Voltage	: 240V

TOP VIEW
 FLOW CONTROL PANEL : Horiz.
 LOUVER : Center

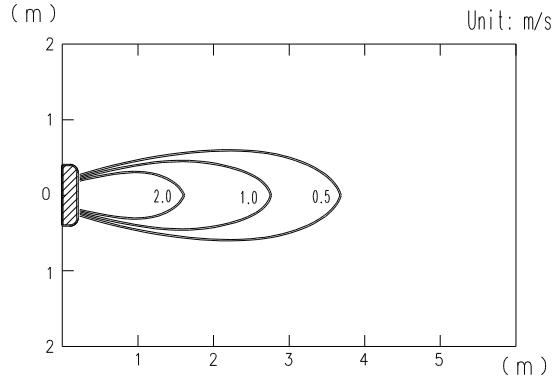

TOP VIEW
 FLOW CONTROL PANEL : Horiz.
 LOUVER : Right & Left

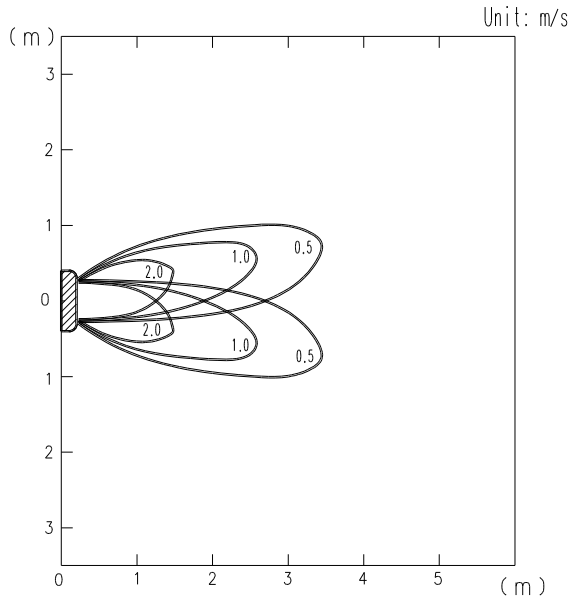

SIDE VIEW
 FRONT CONTROL PANEL : Horiz.
 LOUVER : Center

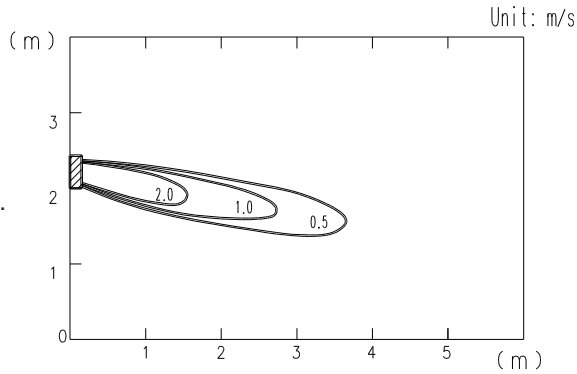

SIDE VIEW
 FLOW CONTROL PANEL : Vert.
 LOUVER : Center

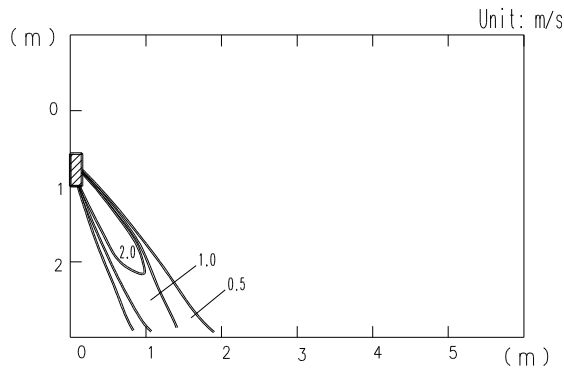

INDOOR UNIT

INDOOR UNIT

■ MODEL : AS9

Conditions	
Fan speed	: High
Operation mode	: Fan
Voltage	: 240V

TOP VIEW
 FLOW CONTROL PANEL : Horiz.
 LOUVER : Center

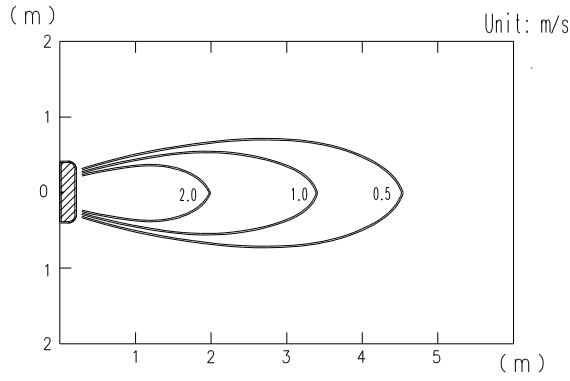

TOP VIEW
 FLOW CONTROL PANEL : Horiz.
 LOUVER : Right & Left

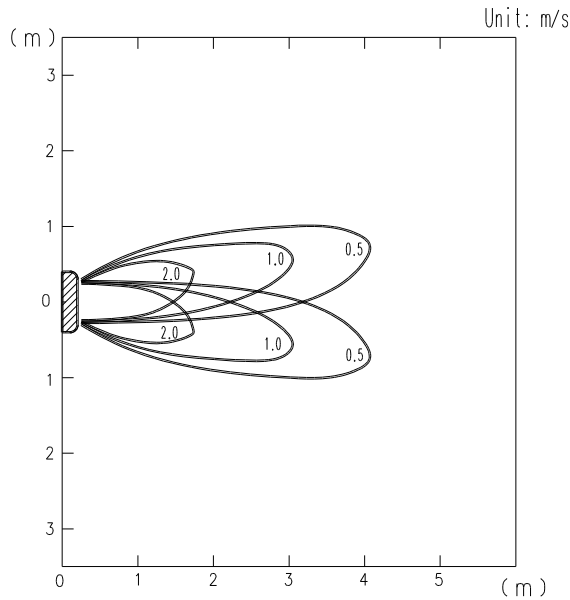

SIDE VIEW
 FRONT CONTROL PANEL : Horiz.
 LOUVER : Center

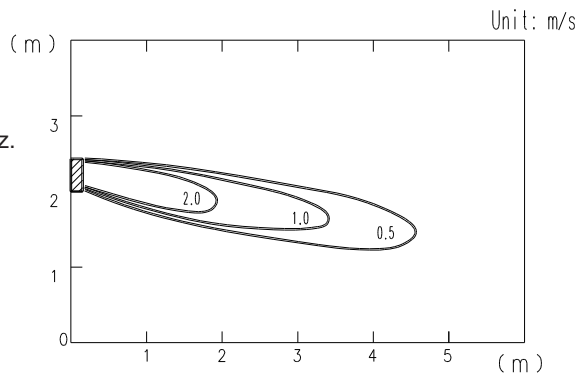

SIDE VIEW
 FLOW CONTROL PANEL : Vert.
 LOUVER : Center

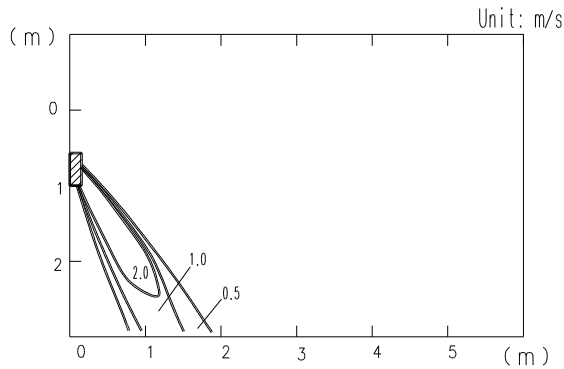

INDOOR UNIT

INDOOR UNIT

MODELS : AS12 , AS14

Conditions	
Fan speed	: High
Operation mode	: Fan
Voltage	: 240V

TOP VIEW
 FLOW CONTROL PANEL : Horiz.
 LOUVER : Center

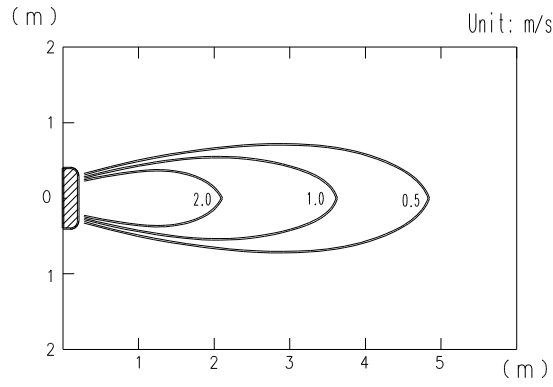

TOP VIEW
 FLOW CONTROL PANEL : Horiz.
 LOUVER : Right & Left

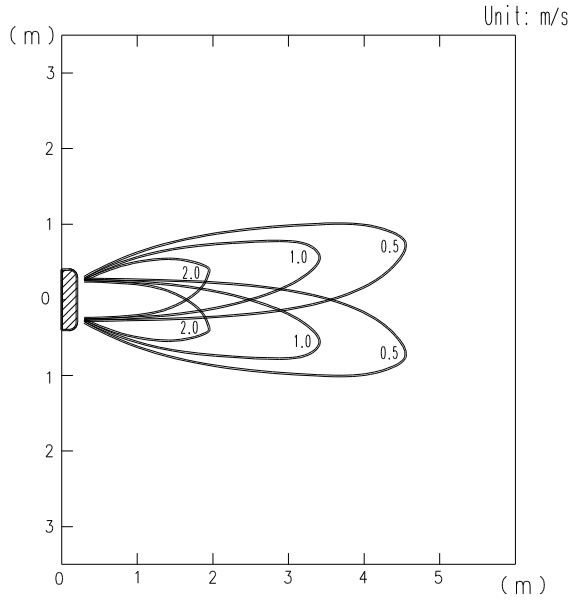

SIDE VIEW
 FRONT CONTROL PANEL : Horiz.
 LOUVER : Center

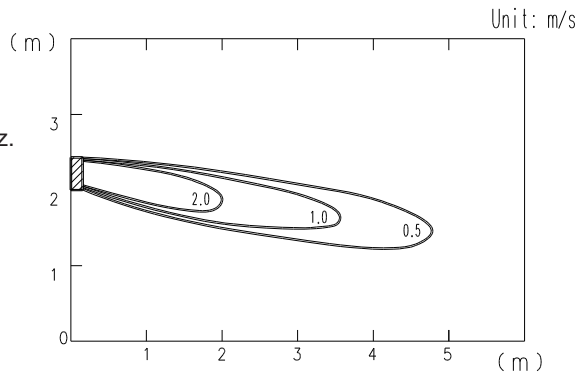

SIDE VIEW
 FLOW CONTROL PANEL : Vert.
 LOUVER : Center

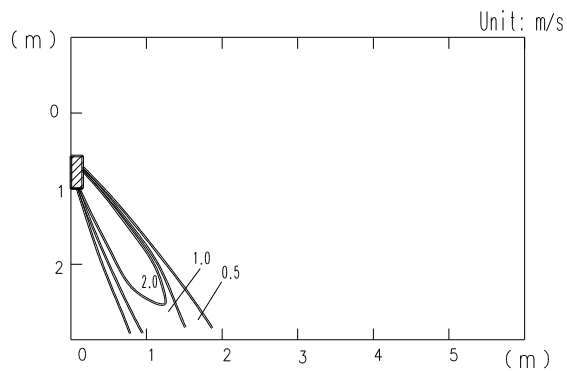

INDOOR UNIT

INDOOR UNIT

4-10-4. WALL MOUNTED TYPE

■ MODEL : AS18

Conditions	
Fan speed	: High
Operation mode	: Fan
Voltage	: 240V

TOP VIEW
FLOW CONTROL PANEL : Horiz.
LOUVER : Center

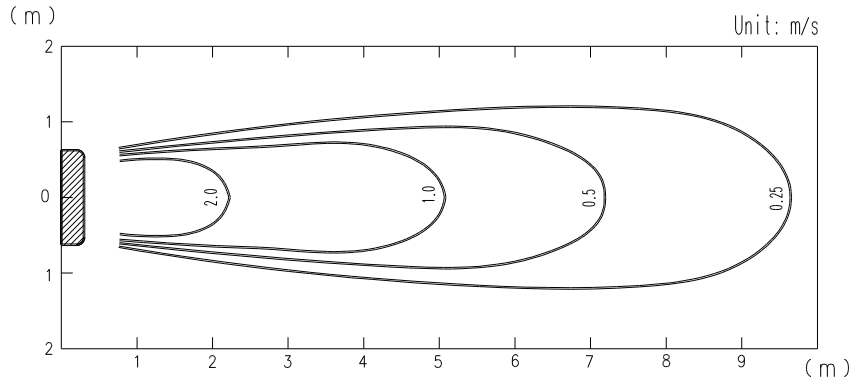

TOP VIEW
FLOW CONTROL PANEL : Horiz.
LOUVER : Right & Left

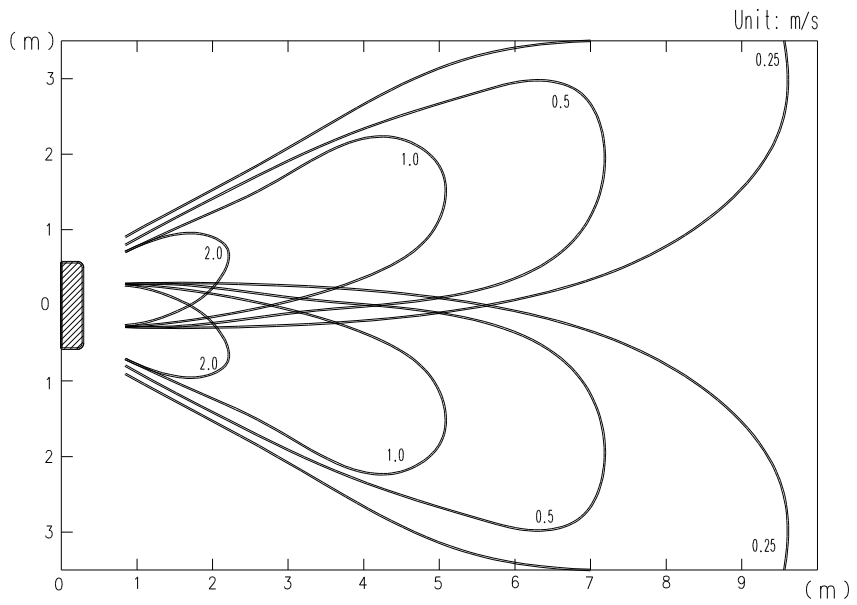

SIDE VIEW
FRONT CONTROL PANEL : Horiz.
LOUVER : Center

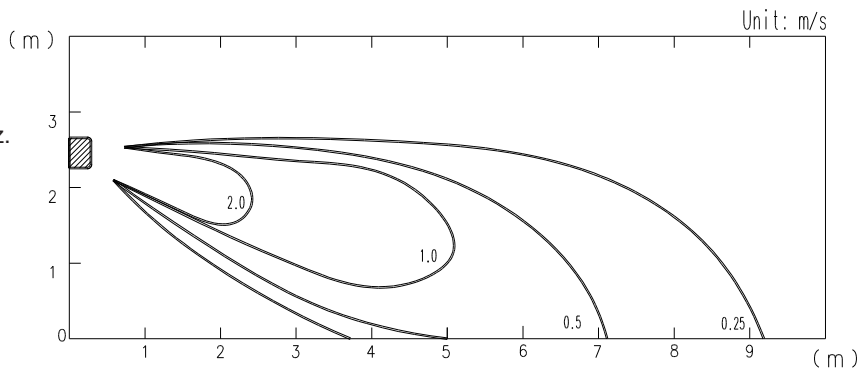

SIDE VIEW
FLOW CONTROL PANEL : Vert.
LOUVER : Center

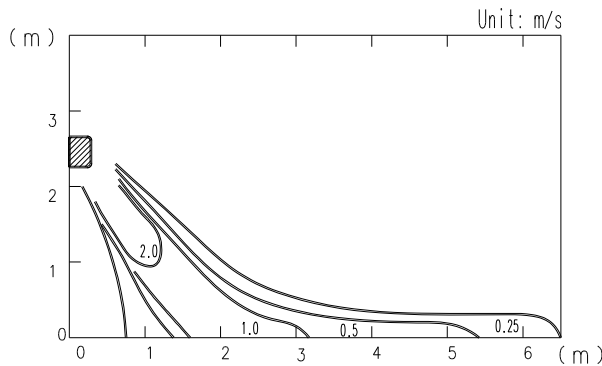

INDOOR UNIT

INDOOR UNIT

MODEL : AS24

Conditions	
Fan speed	: High
Operation mode	: Fan
Voltage	: 240V

TOP VIEW
FLOW CONTROL PANEL : Horiz.
LOUVER : Center

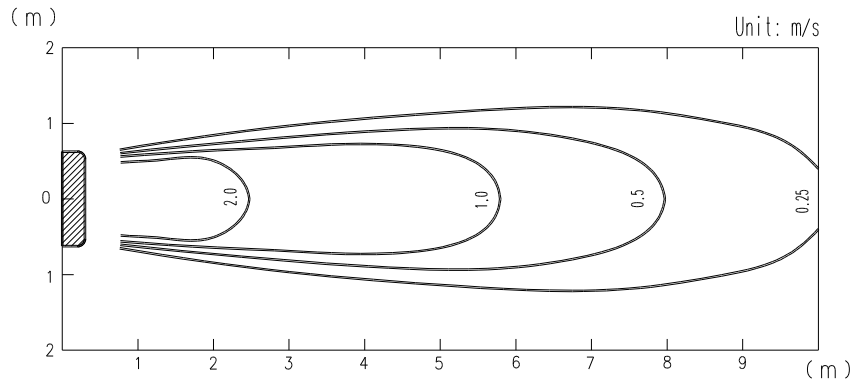

TOP VIEW
FLOW CONTROL PANEL : Horiz.
LOUVER : Right & Left

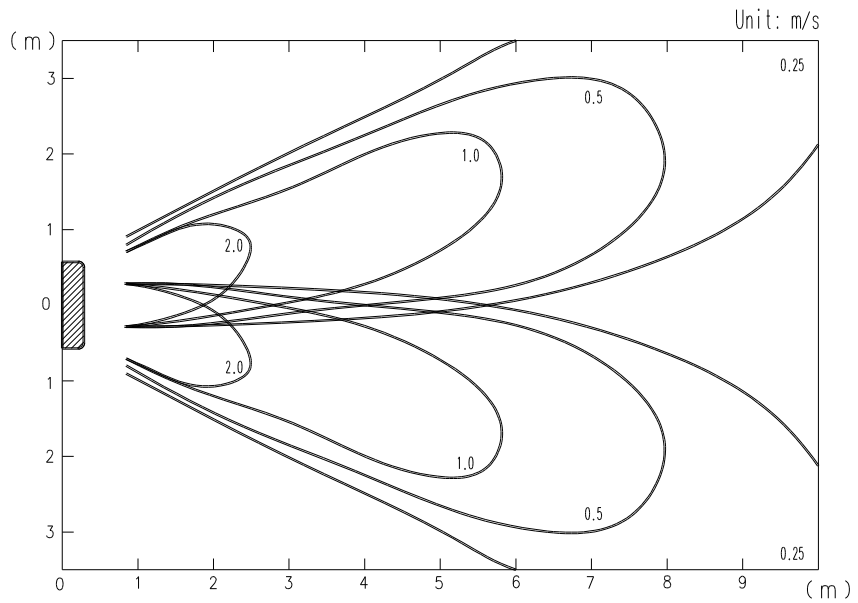

SIDE VIEW
FRONT CONTROL PANEL : Horiz.
LOUVER : Center

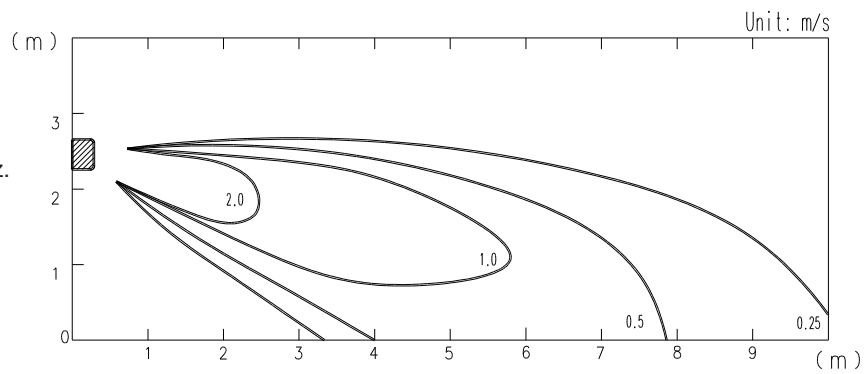

SIDE VIEW
FLOW CONTROL PANEL : Vert.
LOUVER : Center

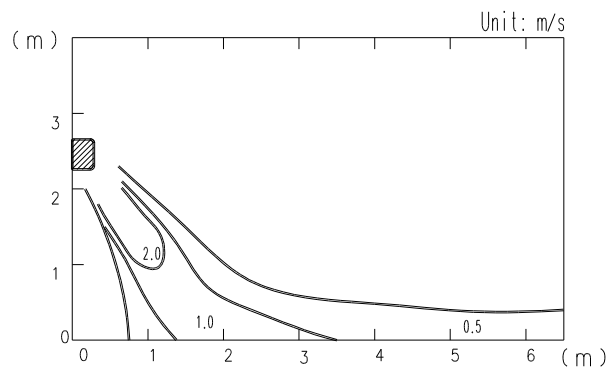

■ MODEL : AS30

Conditions
 Fan speed : High
 Operation mode : Fan
 Voltage : 240V

TOP VIEW
 FLOW CONTROL PANEL : Horiz.
 LOUVER : Center

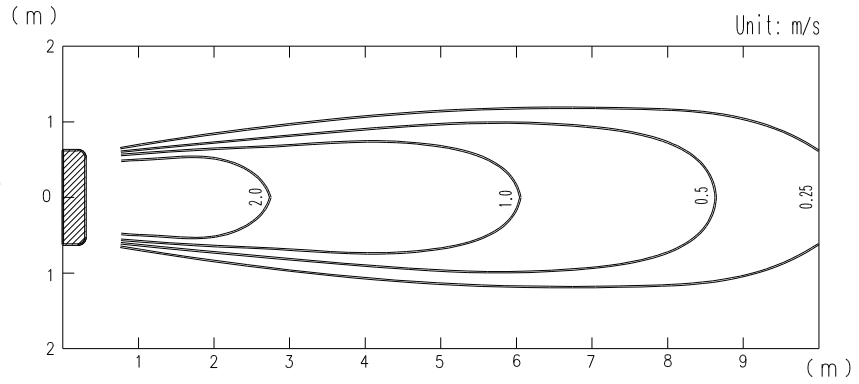

TOP VIEW
 FLOW CONTROL PANEL : Horiz.
 LOUVER : Right & Left

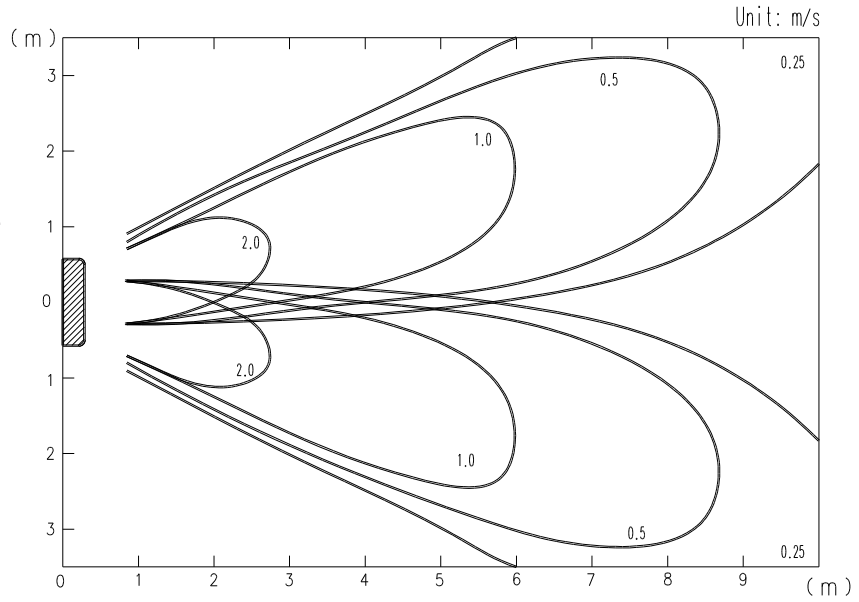

SIDE VIEW
 FRONT CONTROL PANEL : Horiz.
 LOUVER : Center

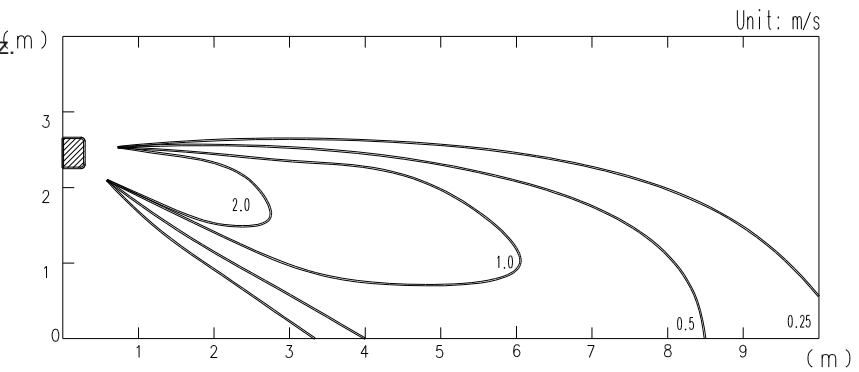

SIDE VIEW
 FLOW CONTROL PANEL : Vert.
 LOUVER : Center

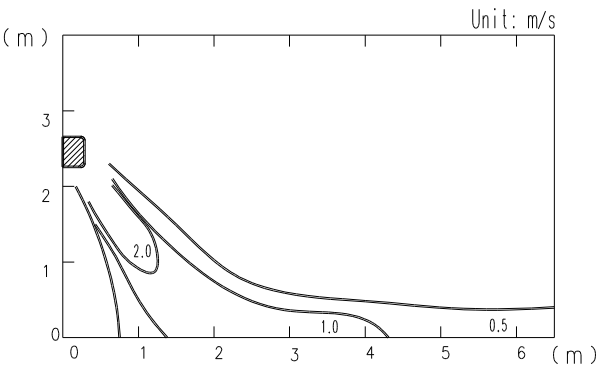

4-11. FAN PERFORMANCE AND AIR FLOW

4-11-1. FAN CURVE (COMPACT DUCT TYPE)

■ MODELS : AR7, AR9, AR12, AR14, AR18, AR22

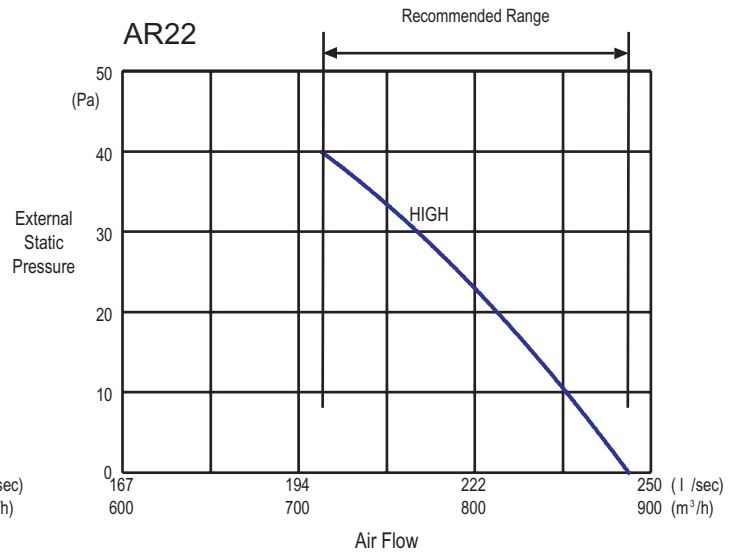
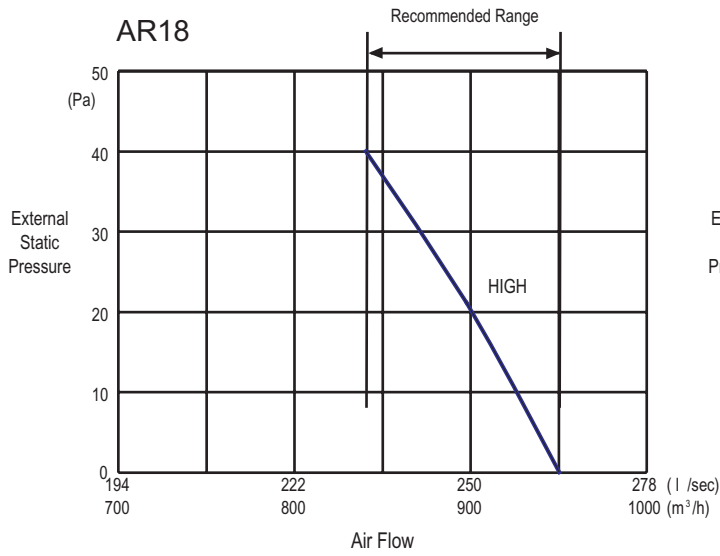
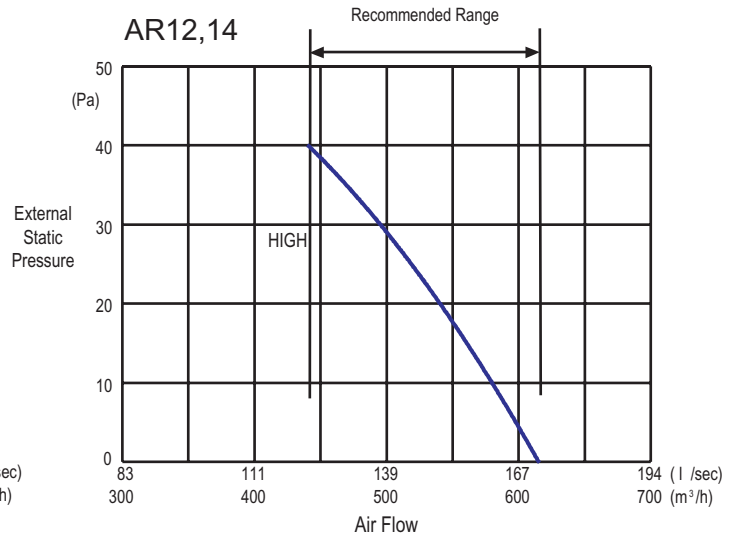
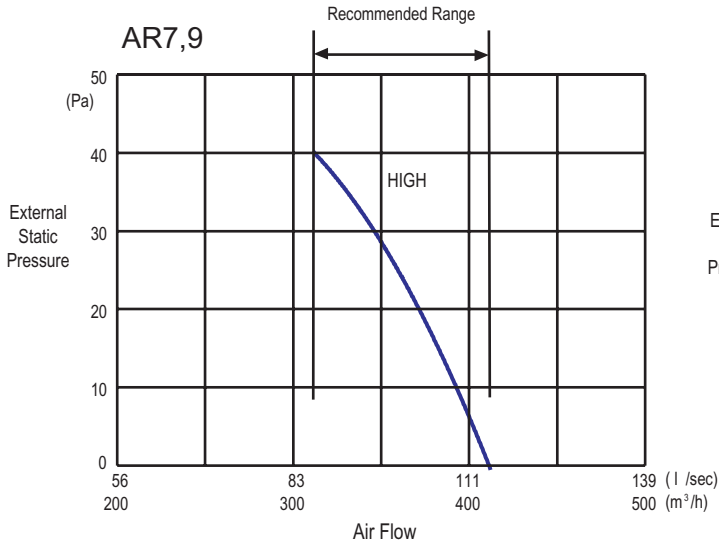

INDOOR UNIT

INDOOR UNIT

CAPACITY BY AIR FLOW

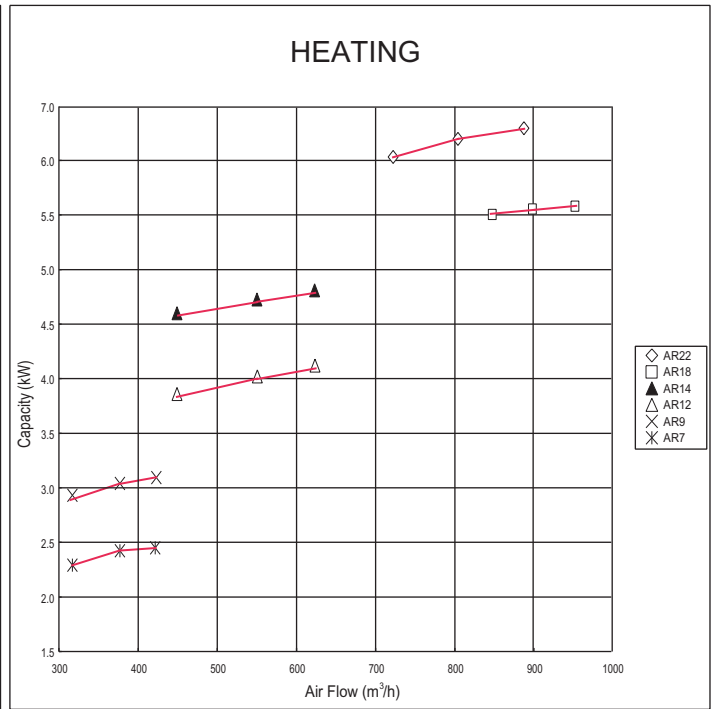
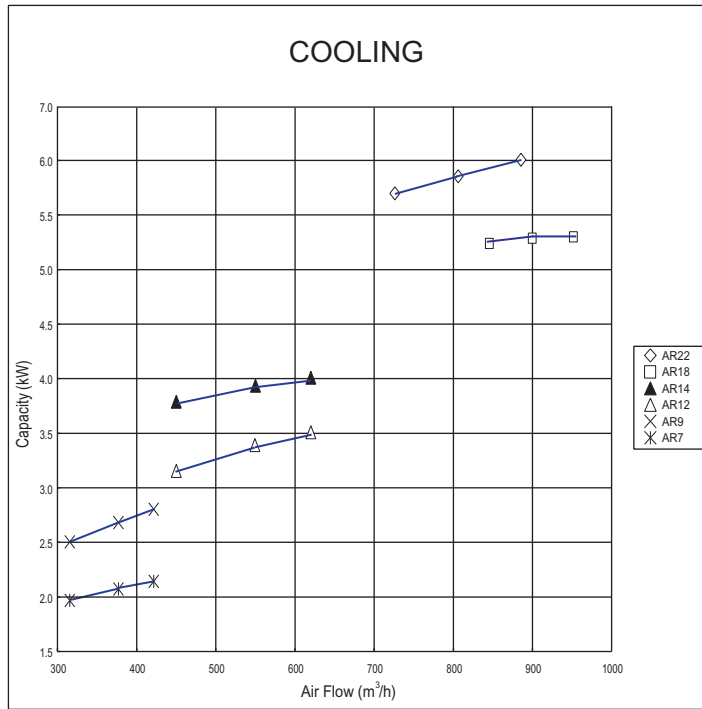

INDOOR UNIT

INDOOR UNIT

OUTLET AIR TEMPERATURE

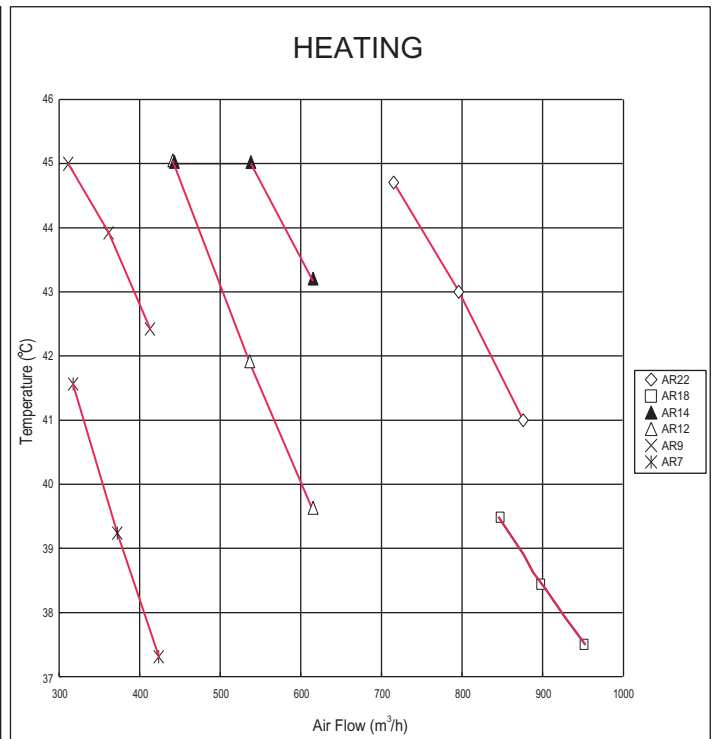
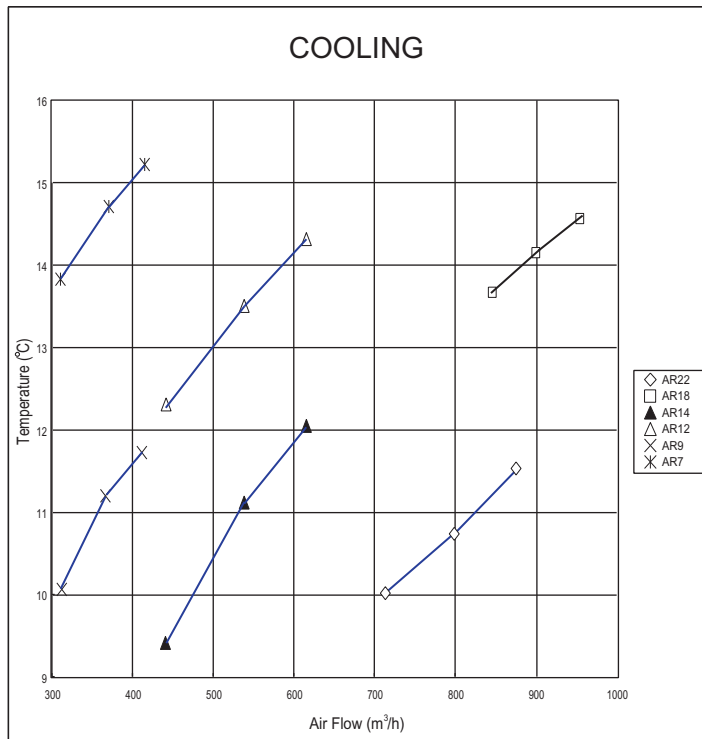

4-11-2. FAN CURVE (LOW STATIC PRESSURE DUCT TYPE)

■ MODEL : ARXB25

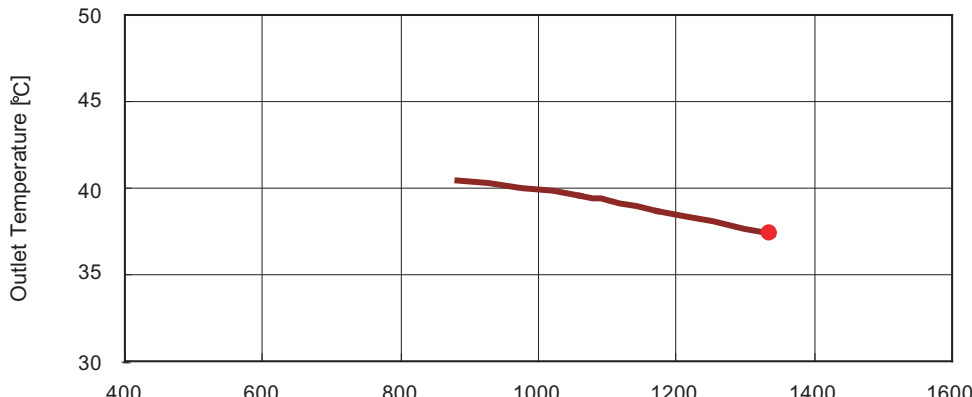
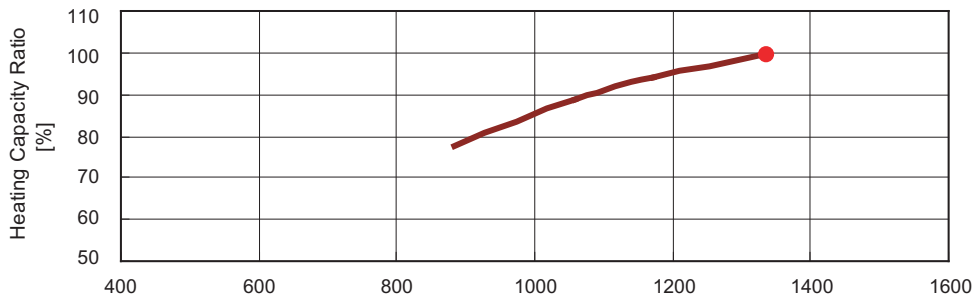
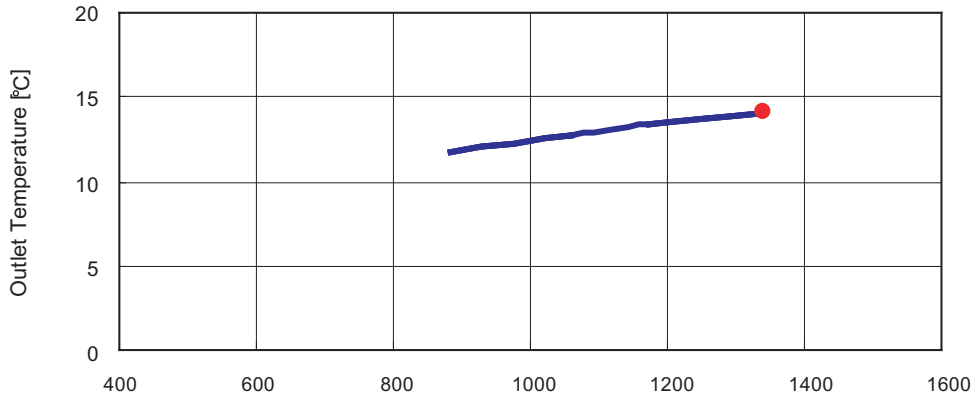
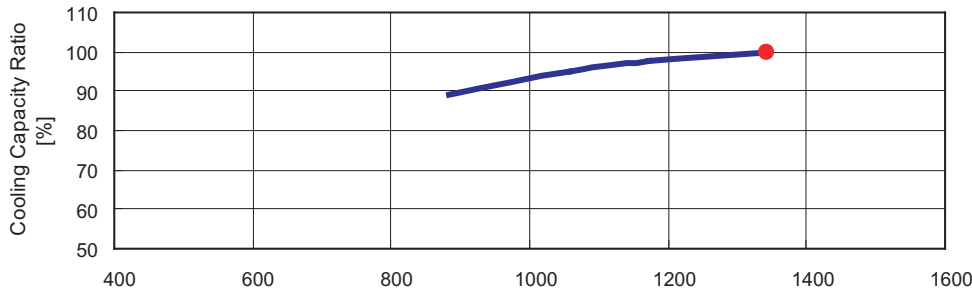
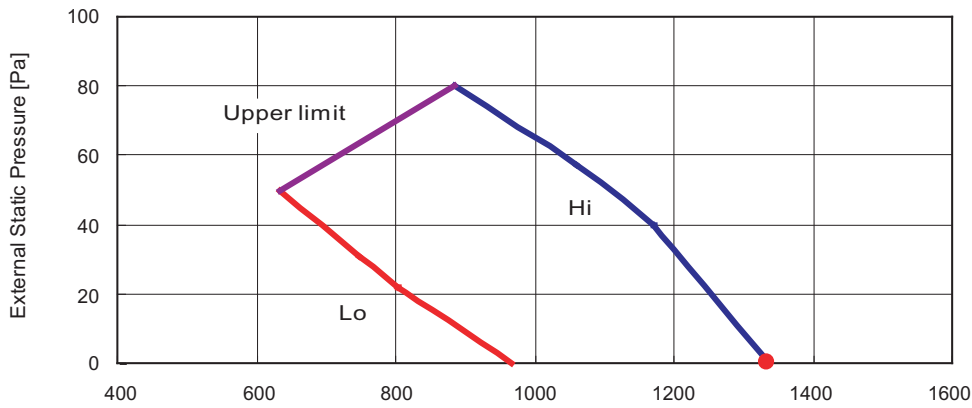

Air Flow [m³/h]

INDOOR UNIT

INDOOR UNIT

MODEL : ARXB30

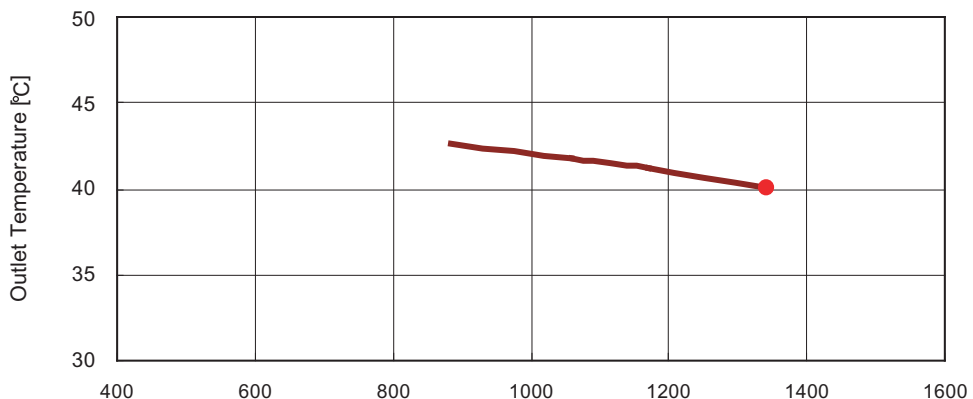
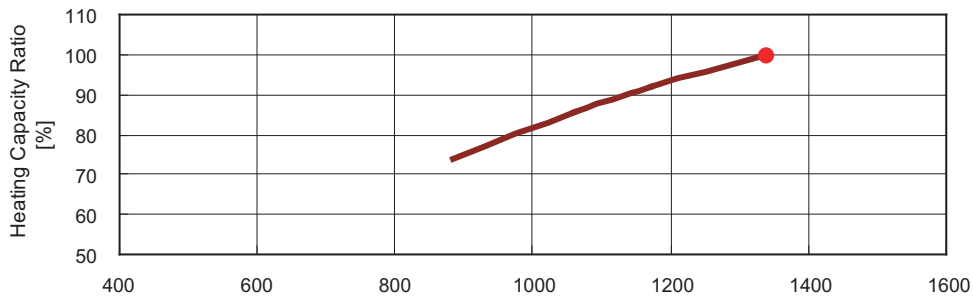
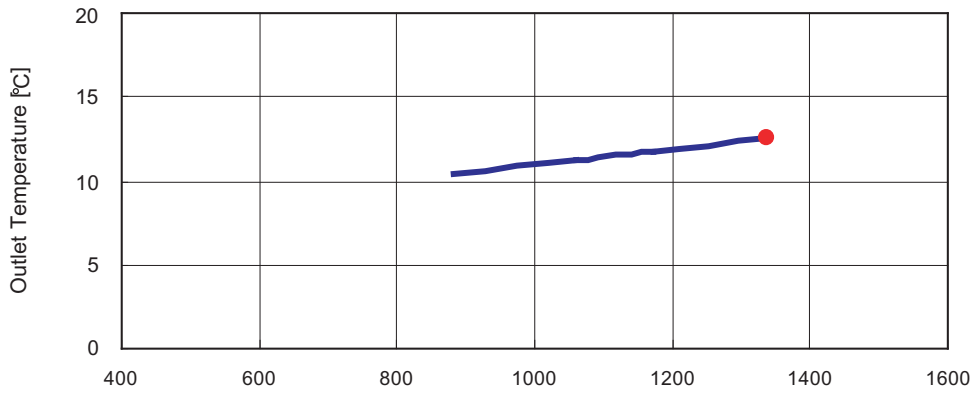
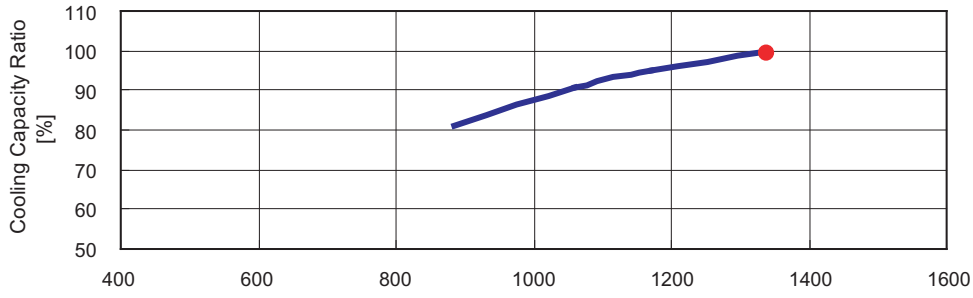
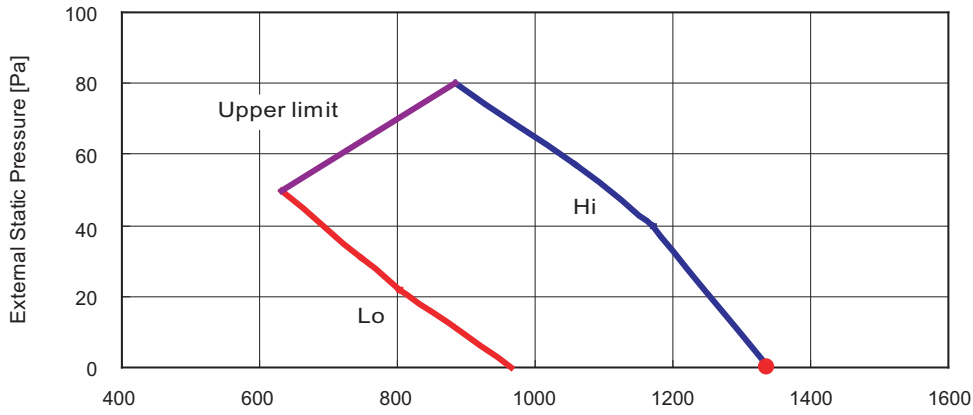

Air Flow [m³/h]

INDOOR UNIT

INDOOR UNIT

4-11-3. FAN CURVE (DUCT TYPE)

■ MODEL : AR25

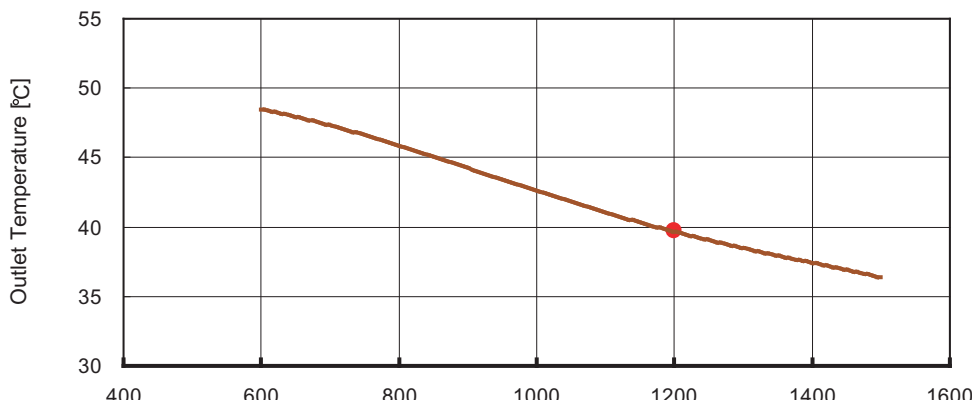
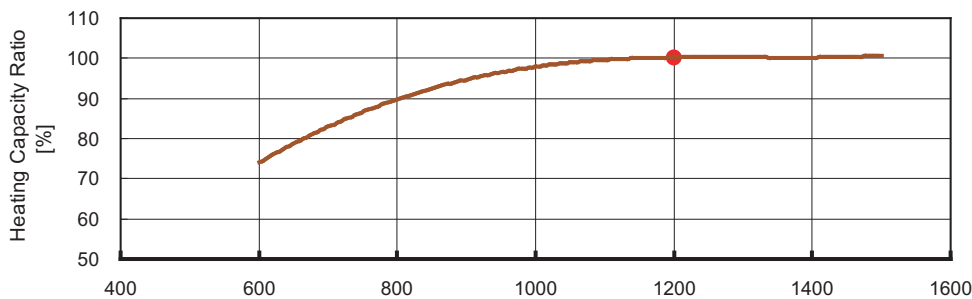
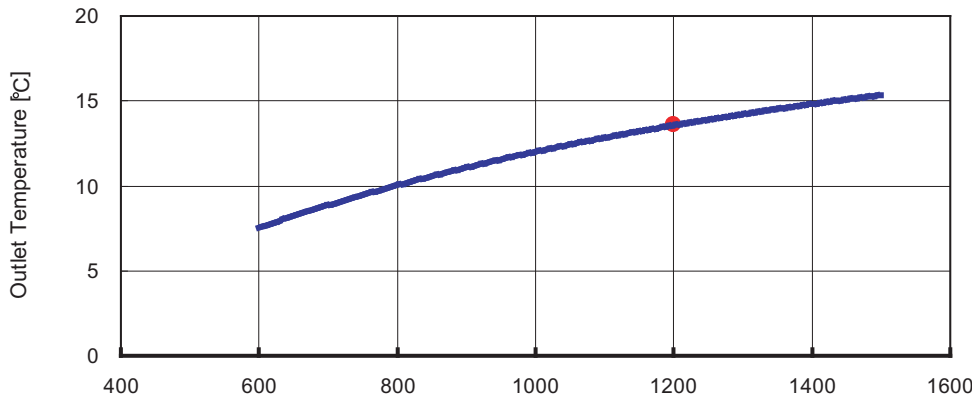
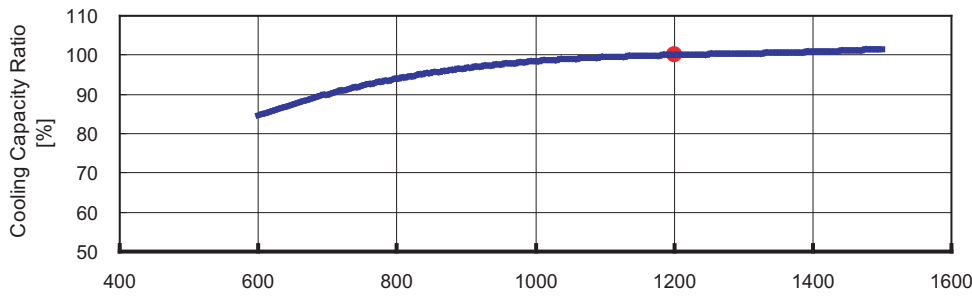
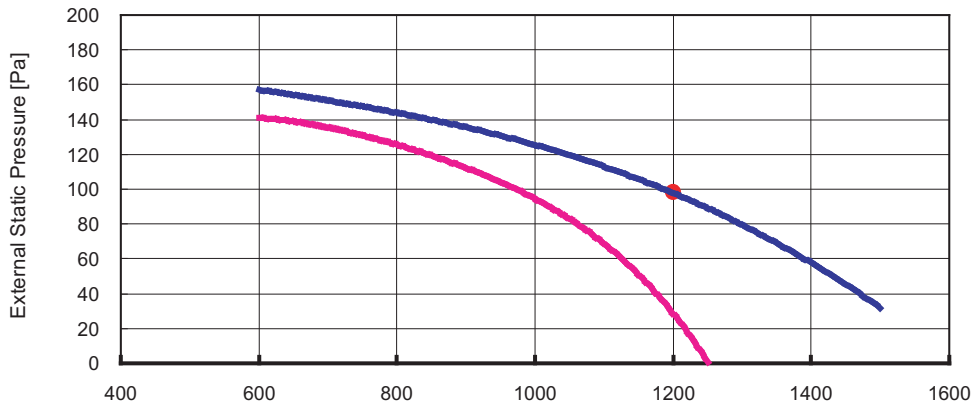

Air Flow [m³/h]

INDOOR UNIT

INDOOR UNIT

MODEL : AR30

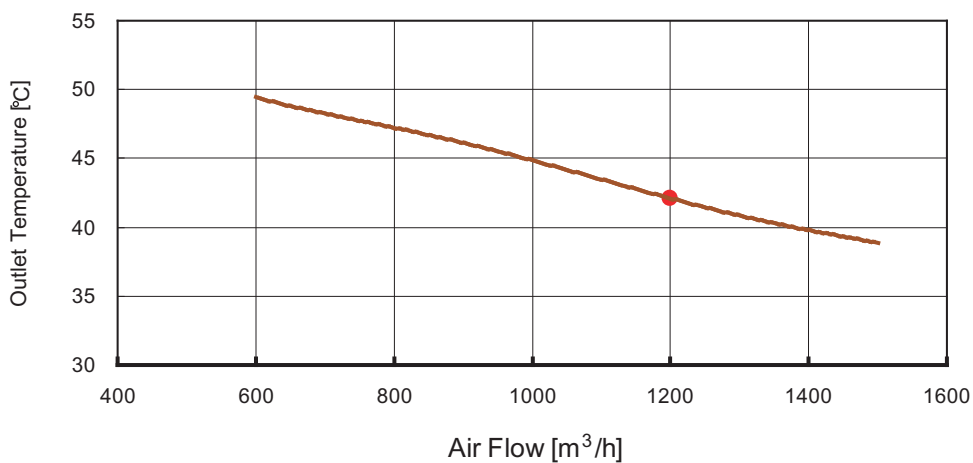
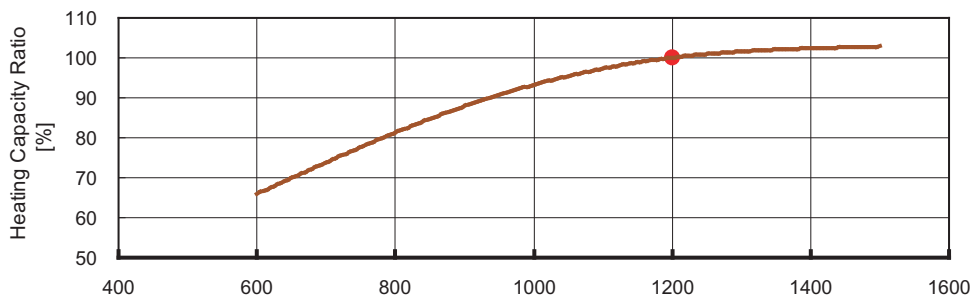
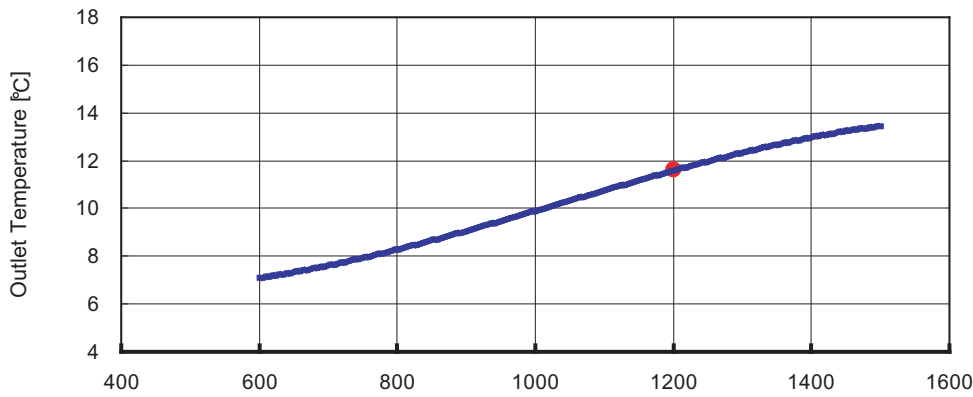
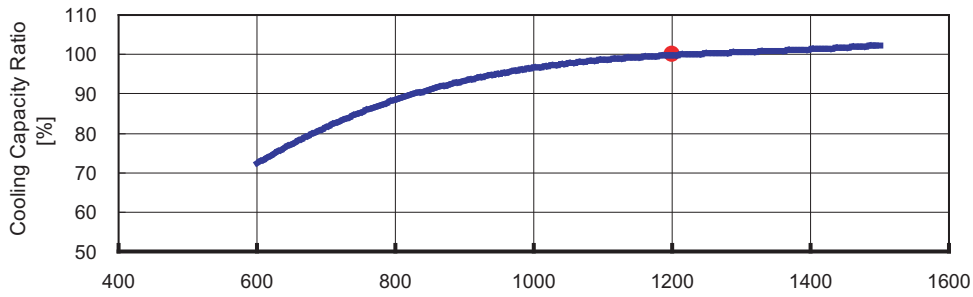
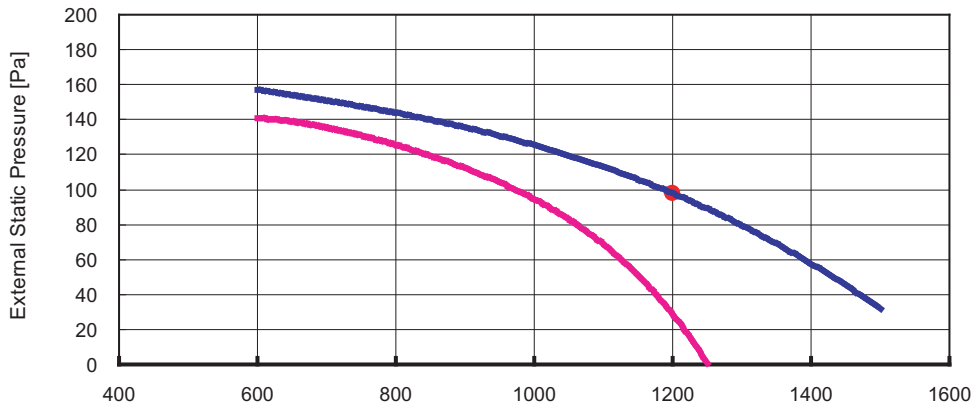

INDOOR UNIT

INDOOR UNIT

MODEL : AR36

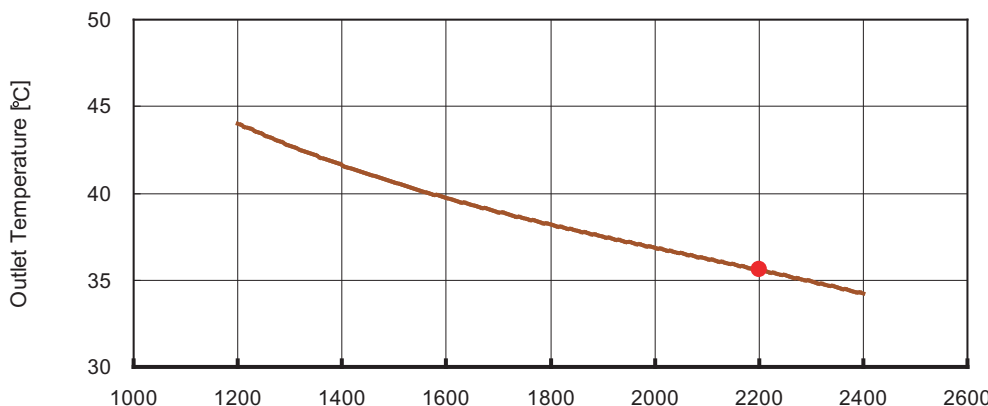
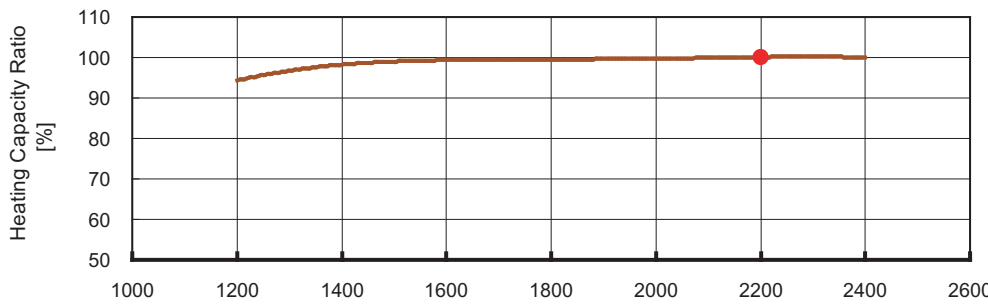
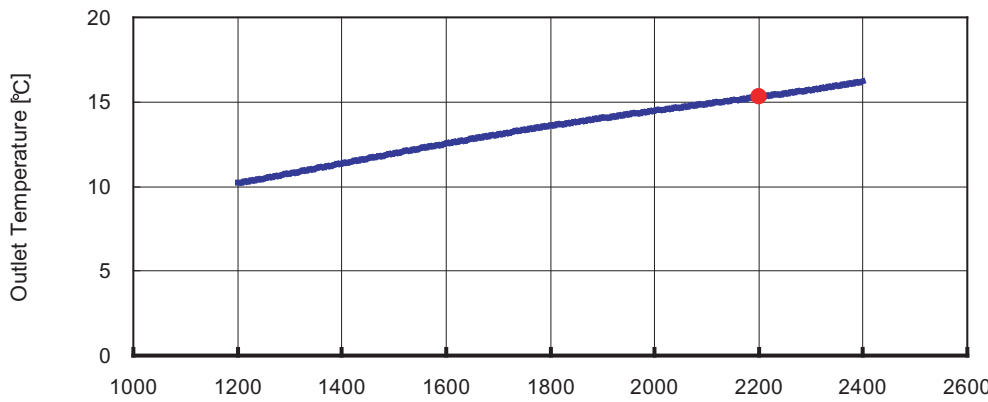
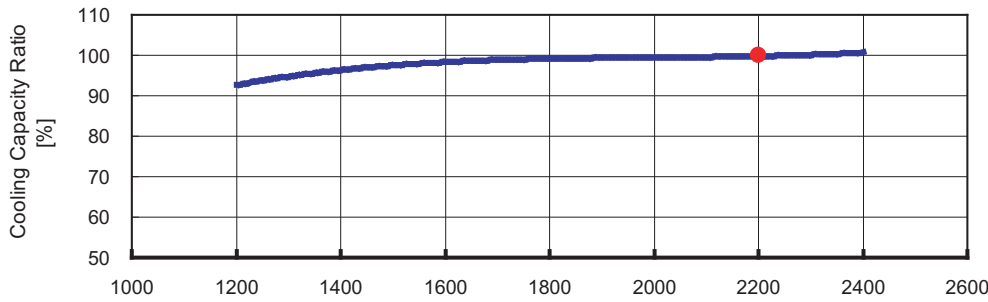
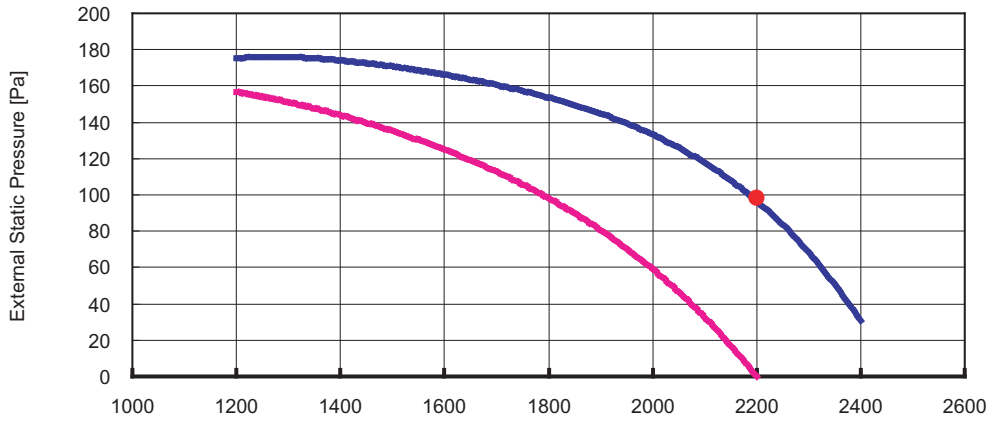

Air Flow [m³/h]

INDOOR UNIT

INDOOR UNIT

MODEL : AR45

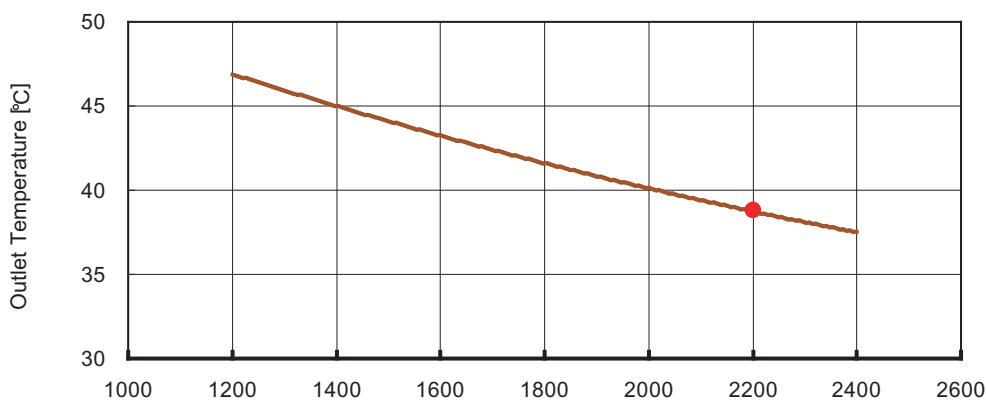
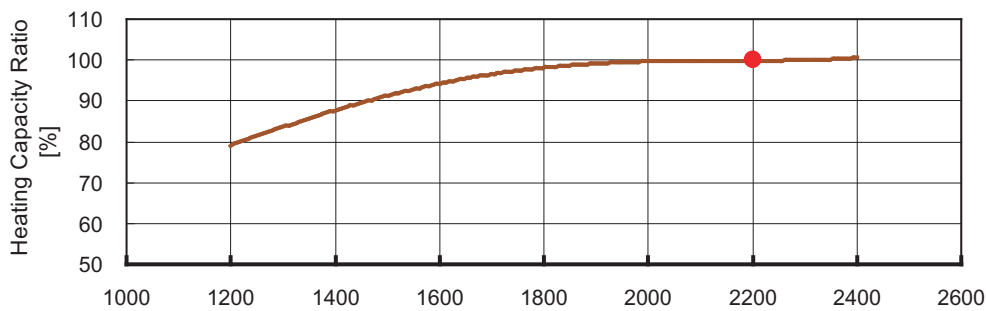
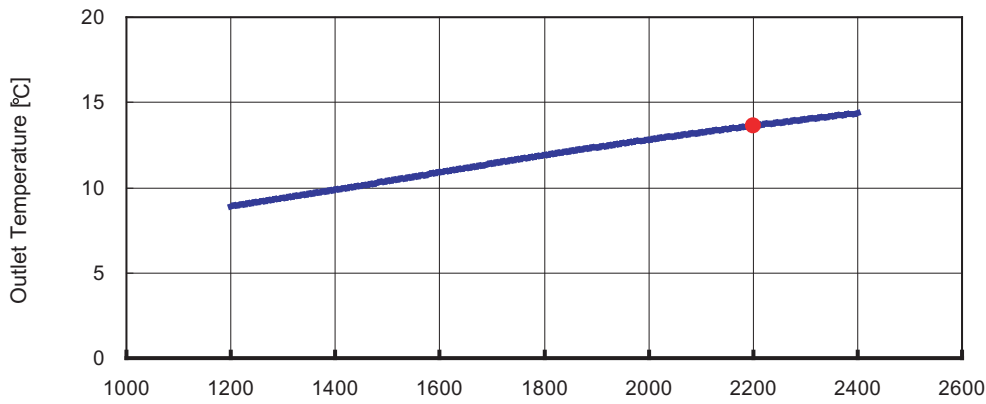
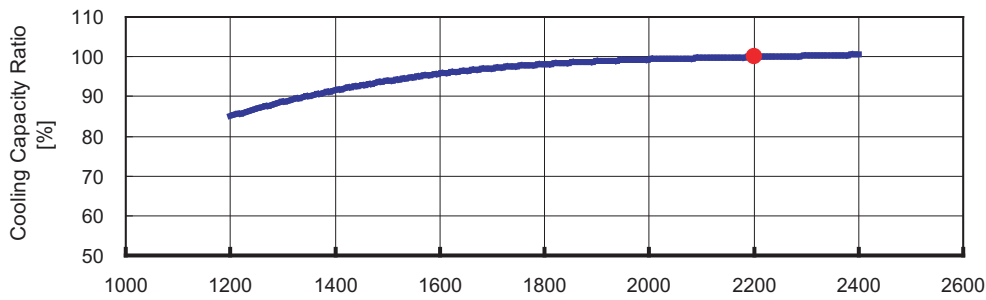
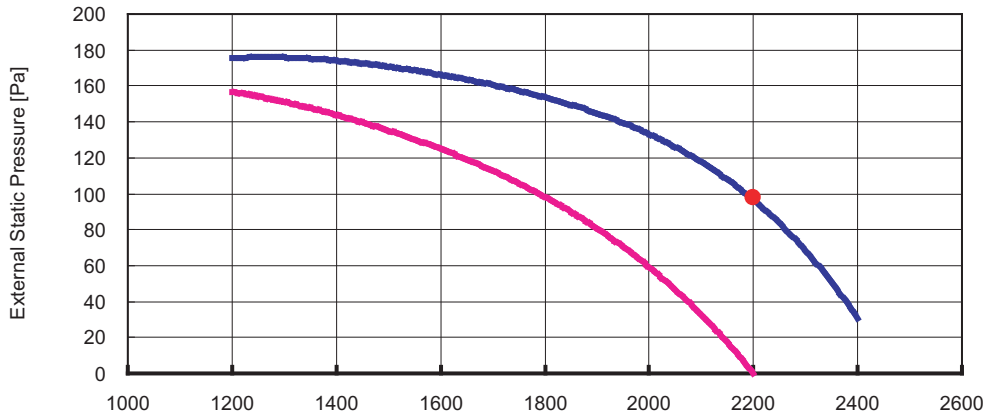

Air Flow [m³/h]

INDOOR UNIT

INDOOR UNIT

4-11-4.DUCT CONNECTION

OUTLET AIR

- MODELS : AU7, AU9, AU12, AU14, AU18

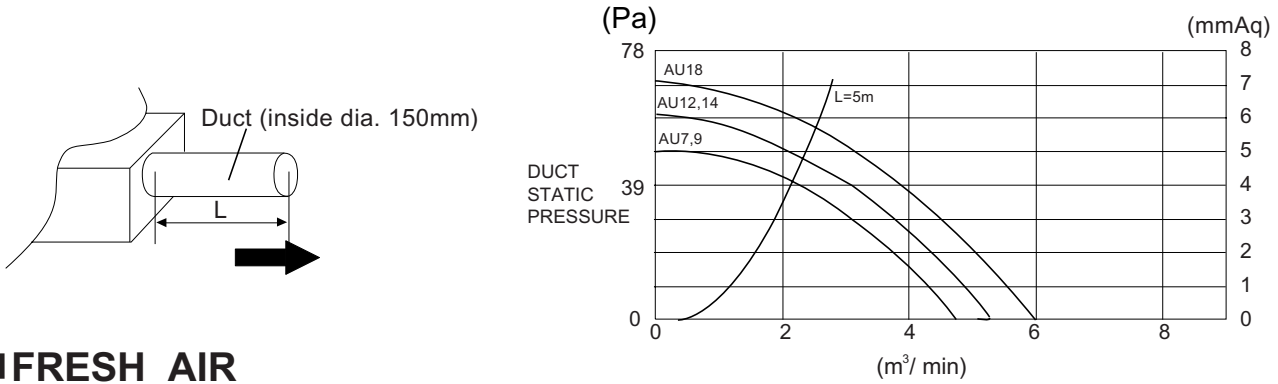

FRESH AIR

- MODELS : AU7, AU9, AU12, AU14, AU18

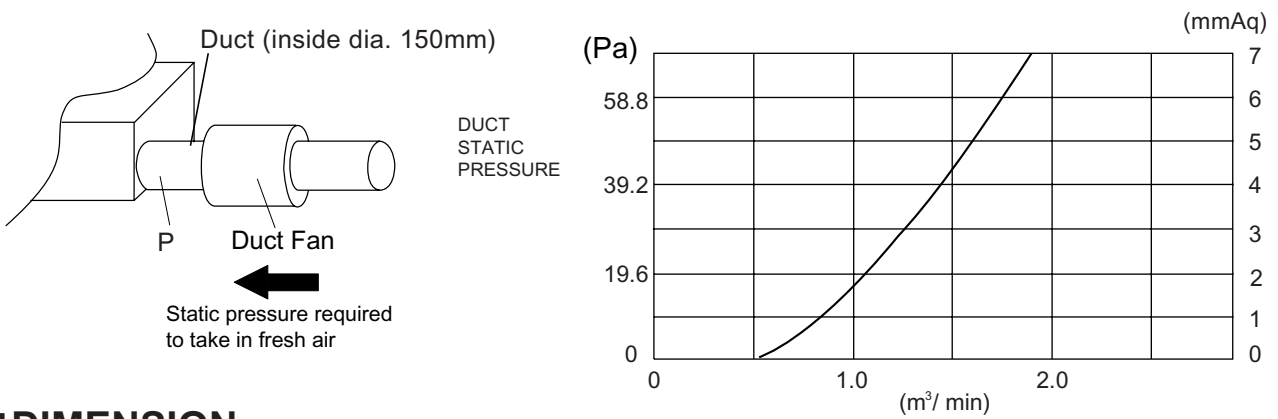

DIMENSION

- Outlet air port

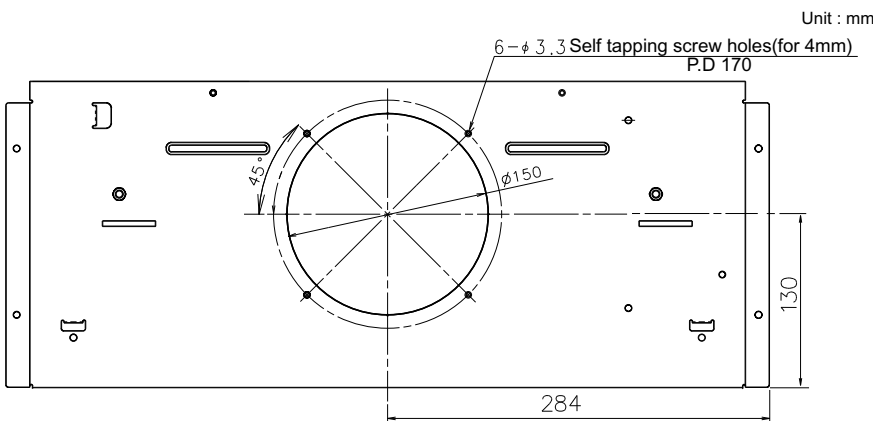

- Fresh air port

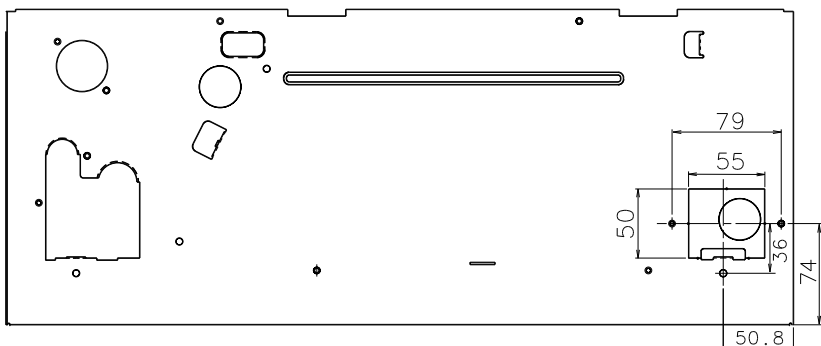

OUTLET AIR

MODELS : AU20, AU25, AU30

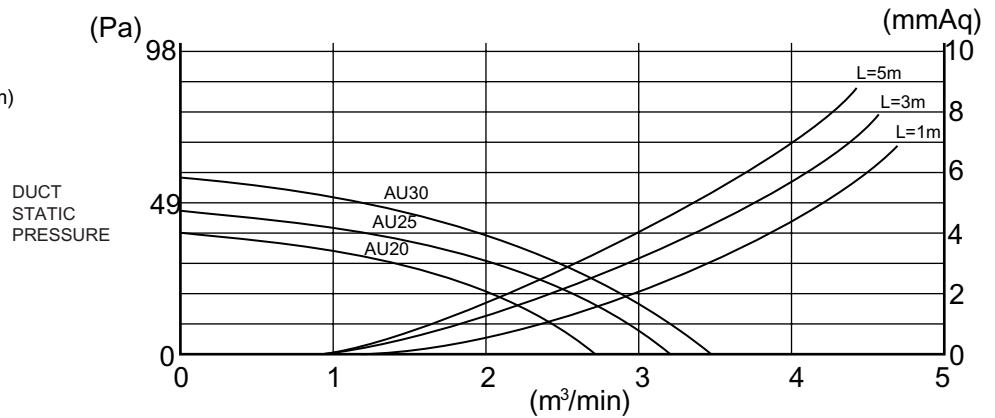
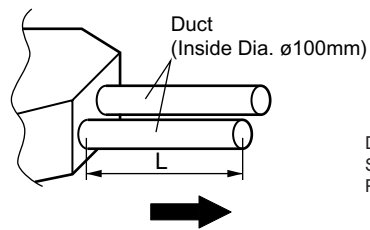
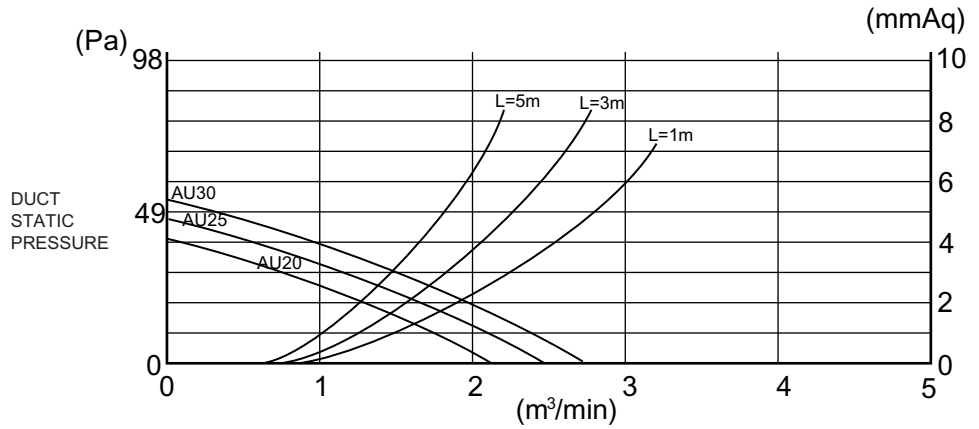
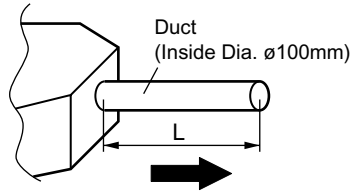

FRESH AIR

MODELS : AU20 , AU25 , AU30

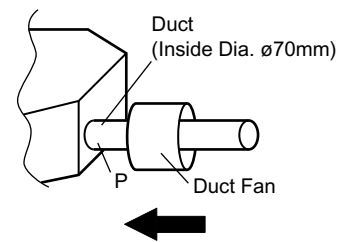

Static pressure required to take in fresh air

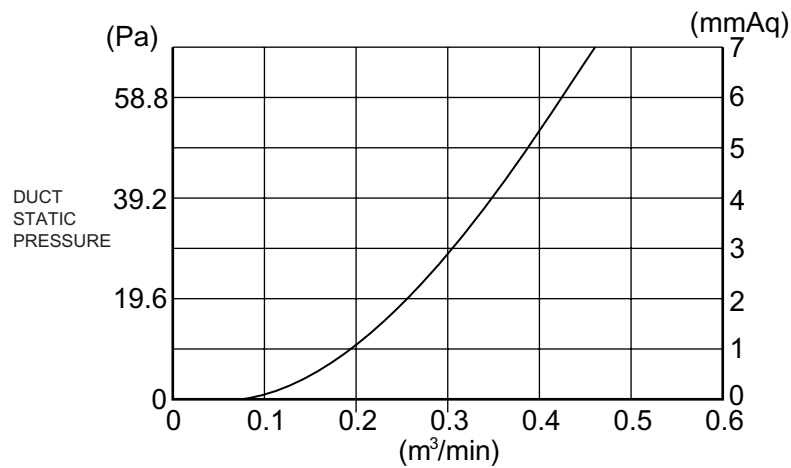

DIMENSION

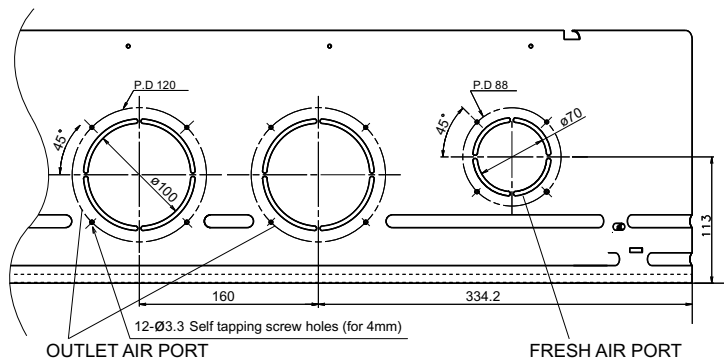

OUTLET AIR

MODELS : AU36, AU45, AU54

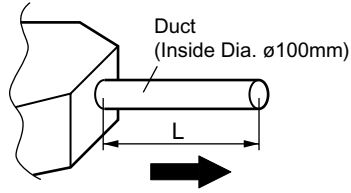

DUCT STATIC PRESSURE

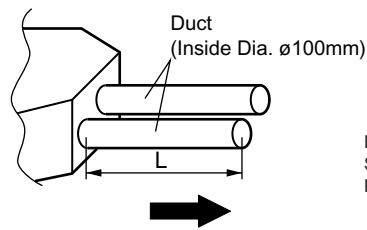
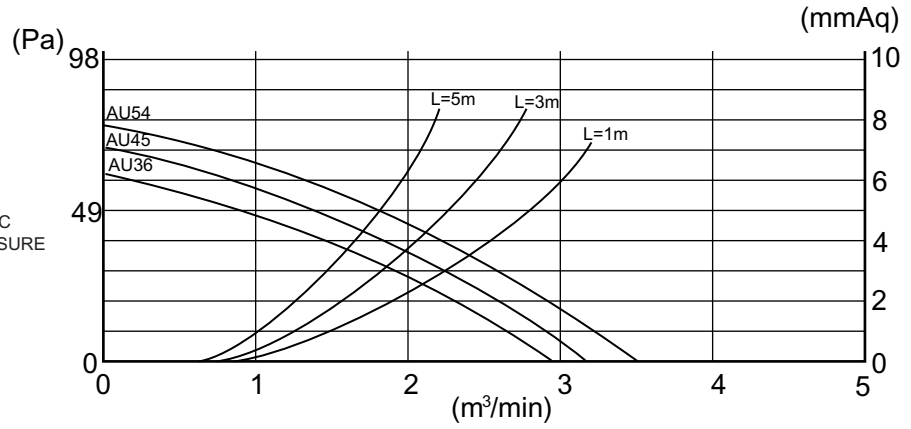

DUCT STATIC PRESSURE

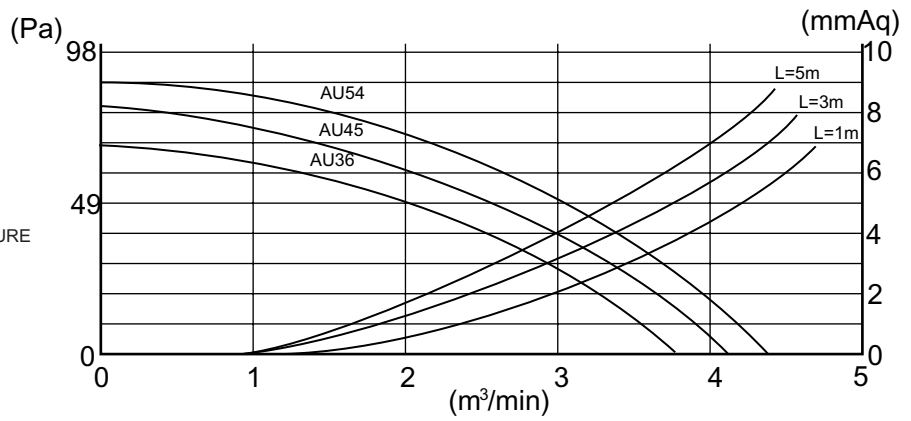

FRESH AIR

MODELS : AU36, AU45, AU54

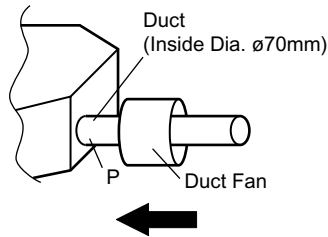

Static pressure required to take in fresh air

DUCT STATIC PRESSURE

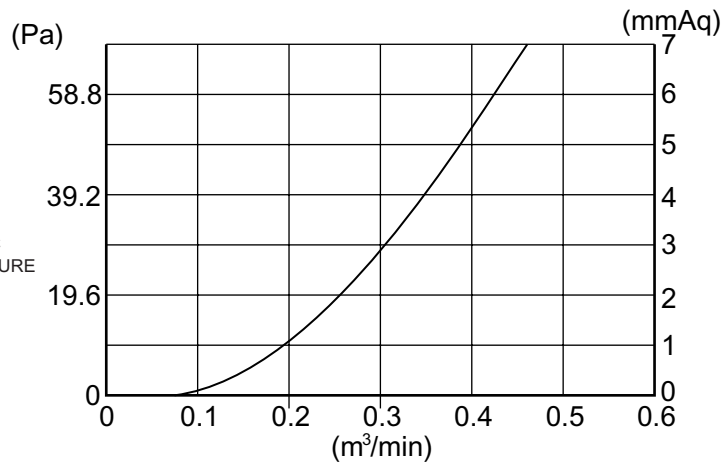

DIMENSION

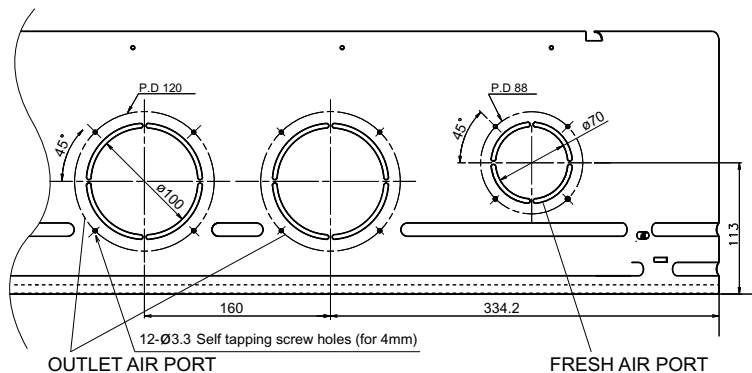

4-12. NOISE LEVEL CURVE

4-12-1. COMPACT DUCT TYPE

Conditions
 Fan speed : High
 Operation mode: FAN
 Voltage : 240V
 Static pressure : 0 Pa

■ MODELS : AR7, AR9

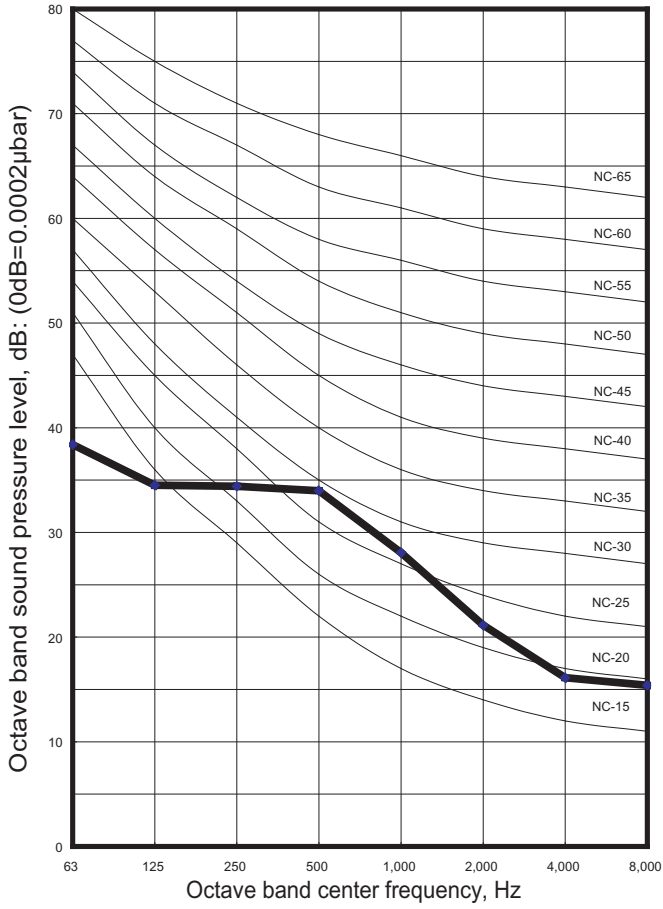

■ MODELS : AR12, AR14

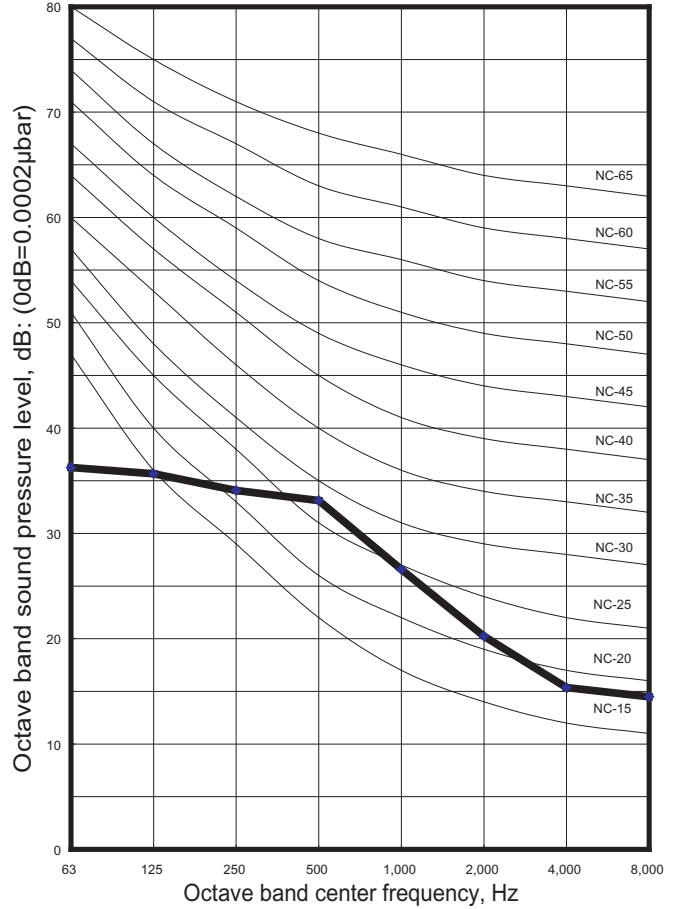

■ MODEL : AR18

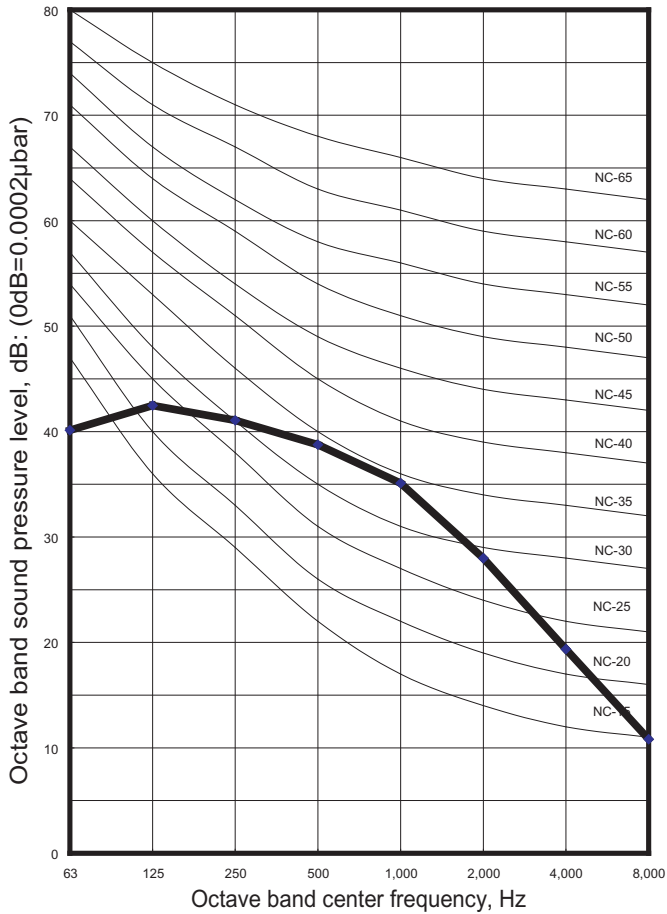

■ MODEL : AR22

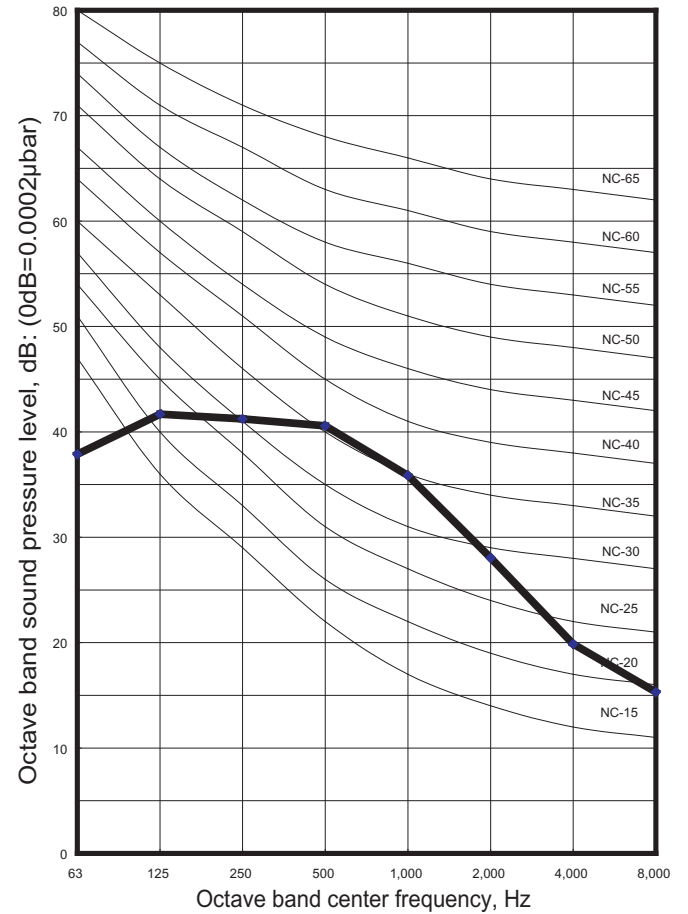

4-12-2. LOW STATIC PRESSURE DUCT TYPE

Conditions	
Fan speed	: High
Operation mode	: FAN
Voltage	: 240V
Static pressure	: 0Pa

MODELS : ARXB25 , ARXB30

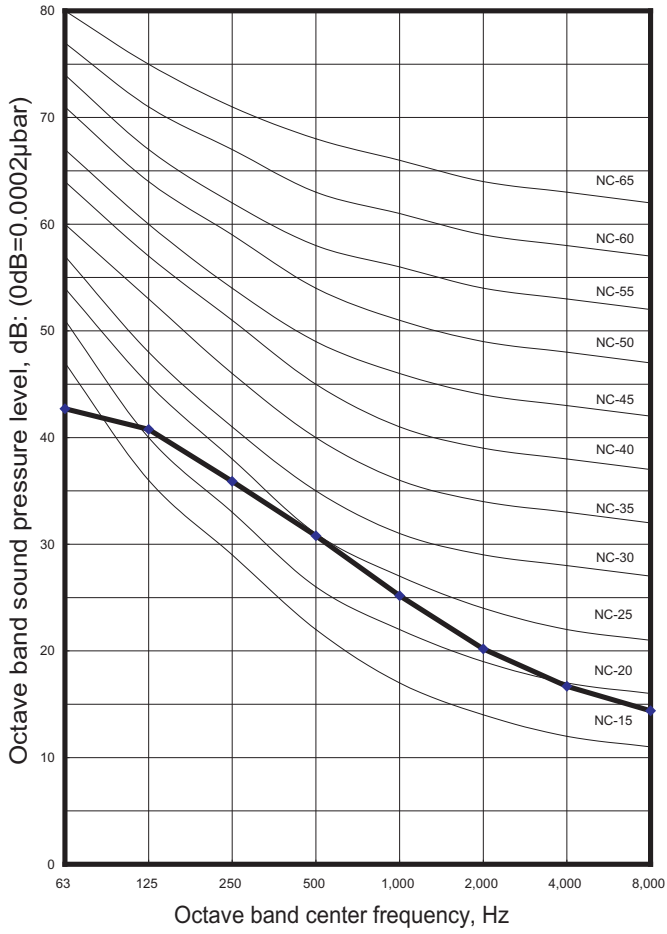

INDOOR UNIT

INDOOR UNIT

4-12-3. DUCT TYPE

Conditions
 Fan speed : High
 Operation mode: FAN
 Voltage : 240V
 Static pressure : 100Pa

MODELS : AR25 , AR30

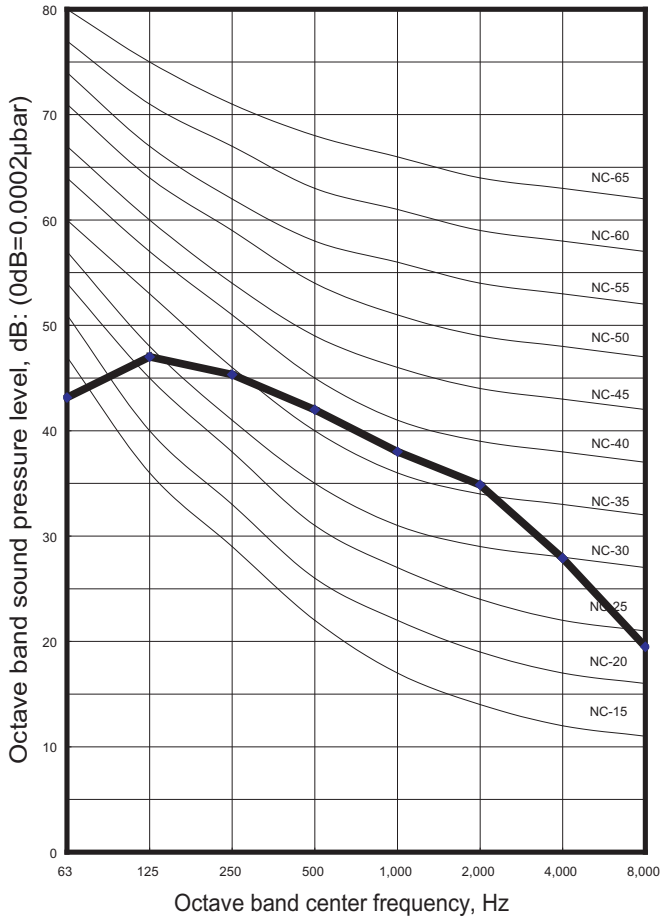

MODELS : AR36 , AR45

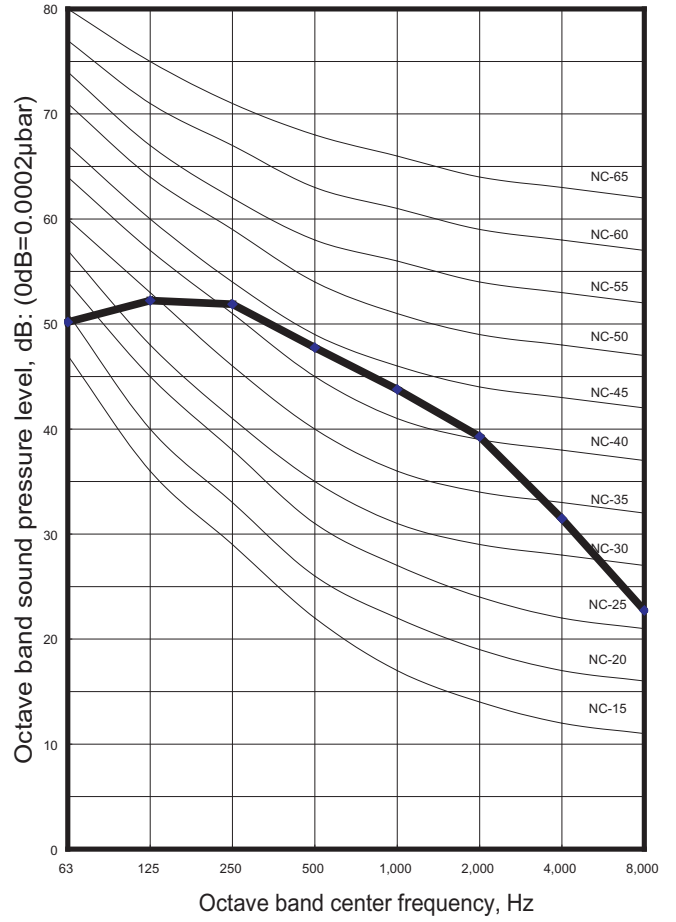

INDOOR UNIT

INDOOR UNIT

4-12-4. COMPACT CASSETTE TYPE

Conditions
 Fan speed : High
 Operation mode: FAN
 Voltage : 240V

MODELS : AU7, AU9

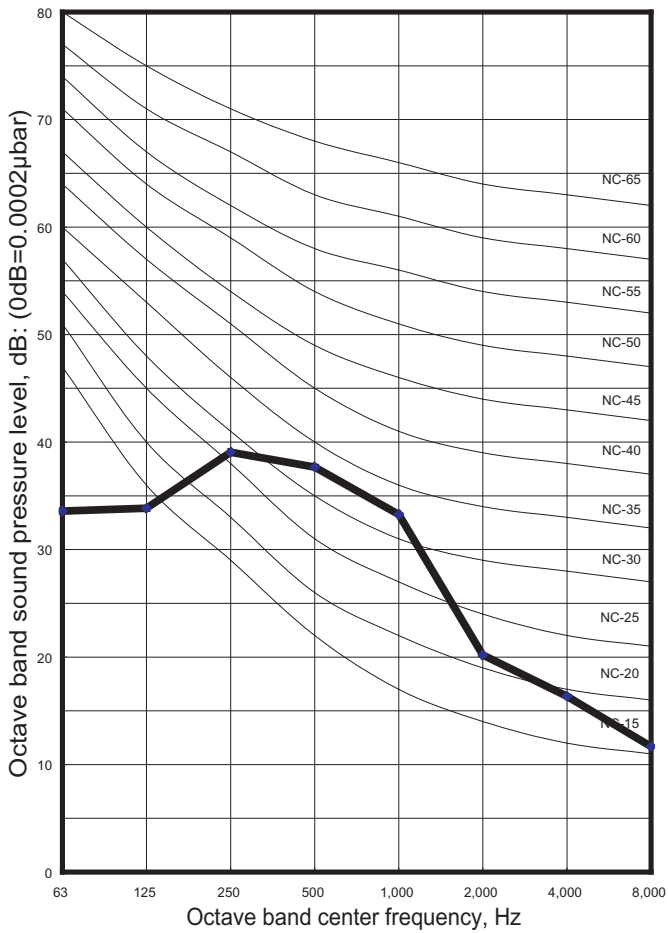

MODELS : AU12, AU14

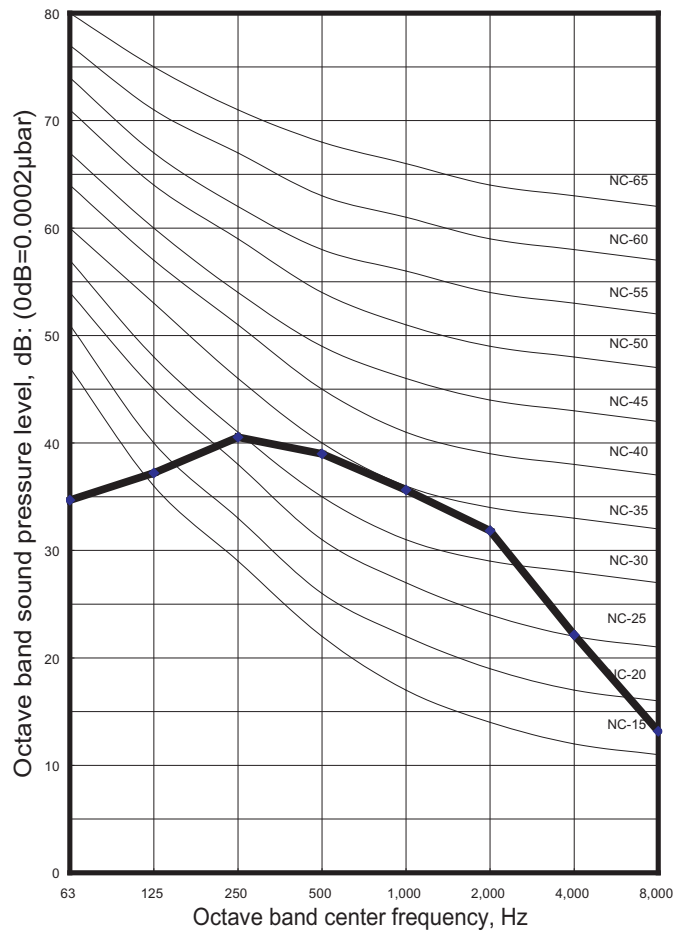

MODEL : AU18

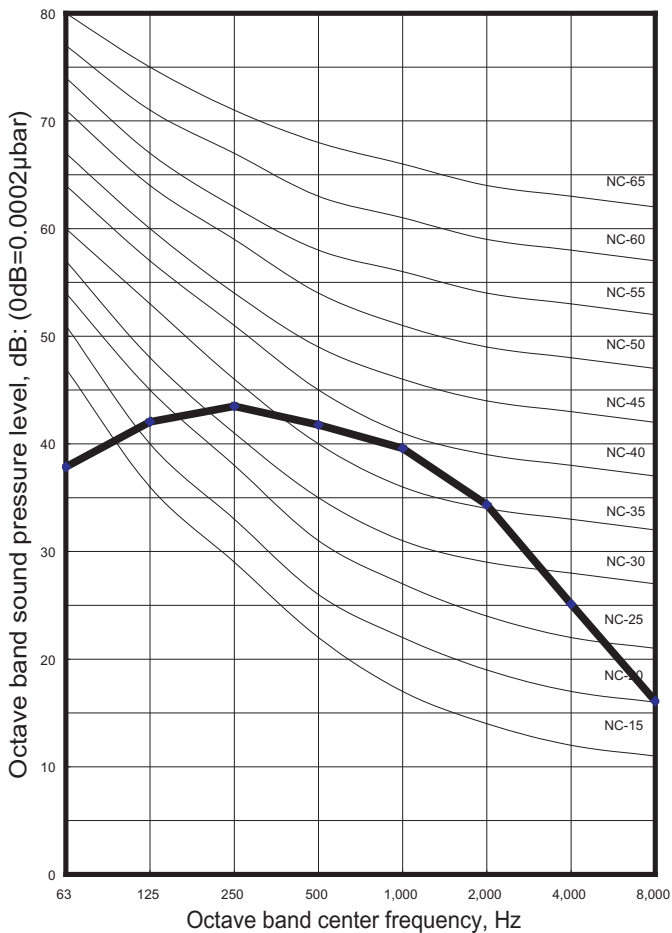

4-12-5. CASSETTE TYPE

Conditions
 Fan speed : High
 Operation mode: FAN
 Voltage : 240V

MODELS : AU20 , AU25

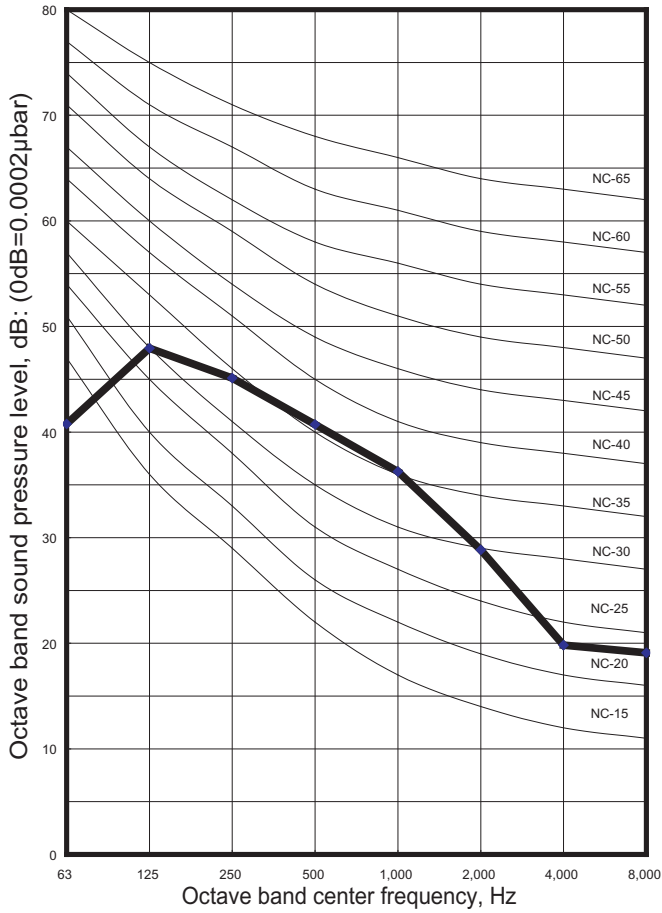

MODEL : AU30

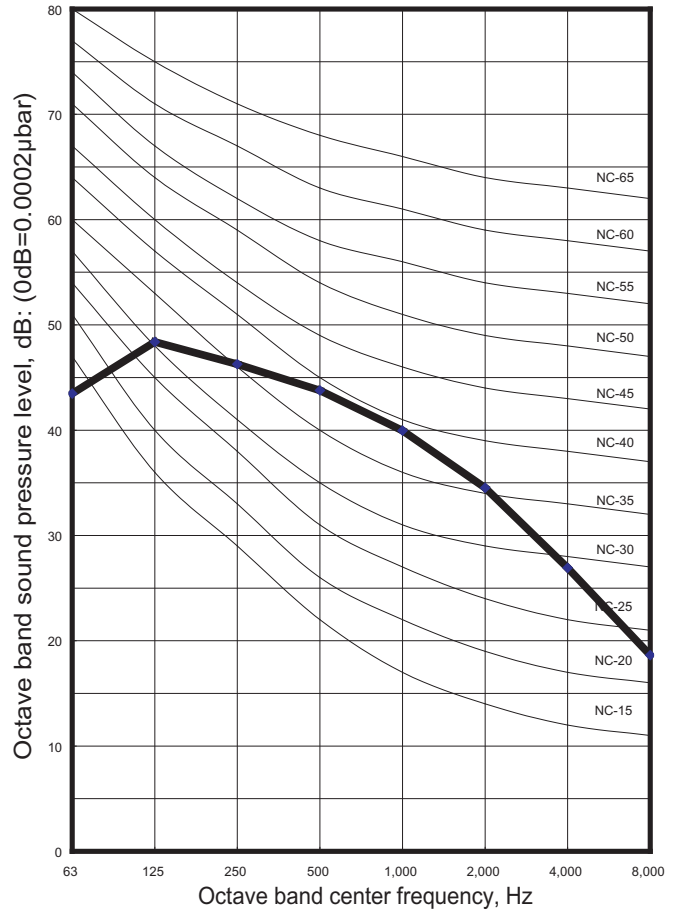

INDOOR UNIT

INDOOR UNIT

Conditions
 Fan speed : High
 Operation mode: FAN
 Voltage : 240V

■ MODEL : AU36

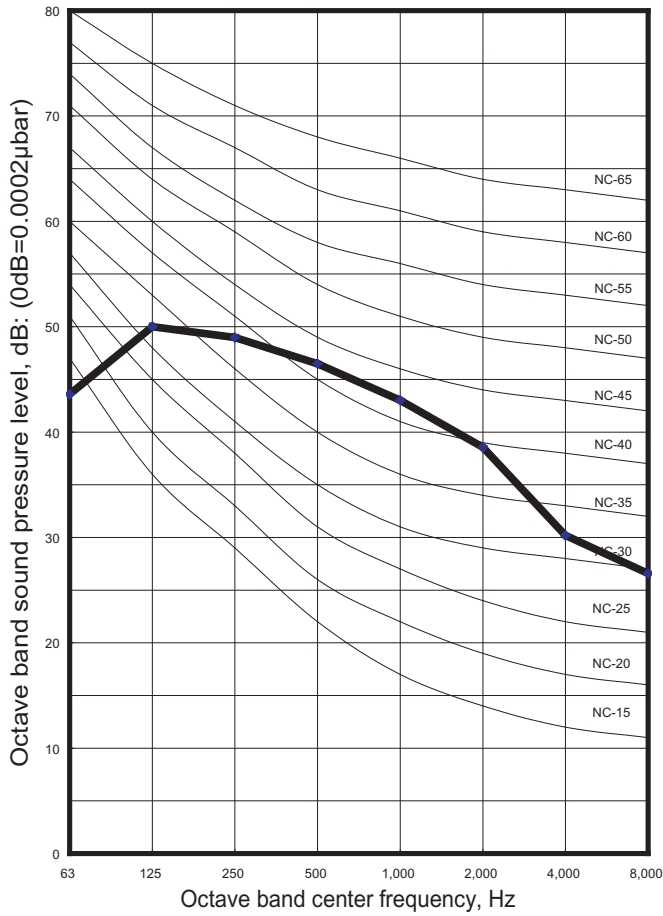

■ MODEL : AU45

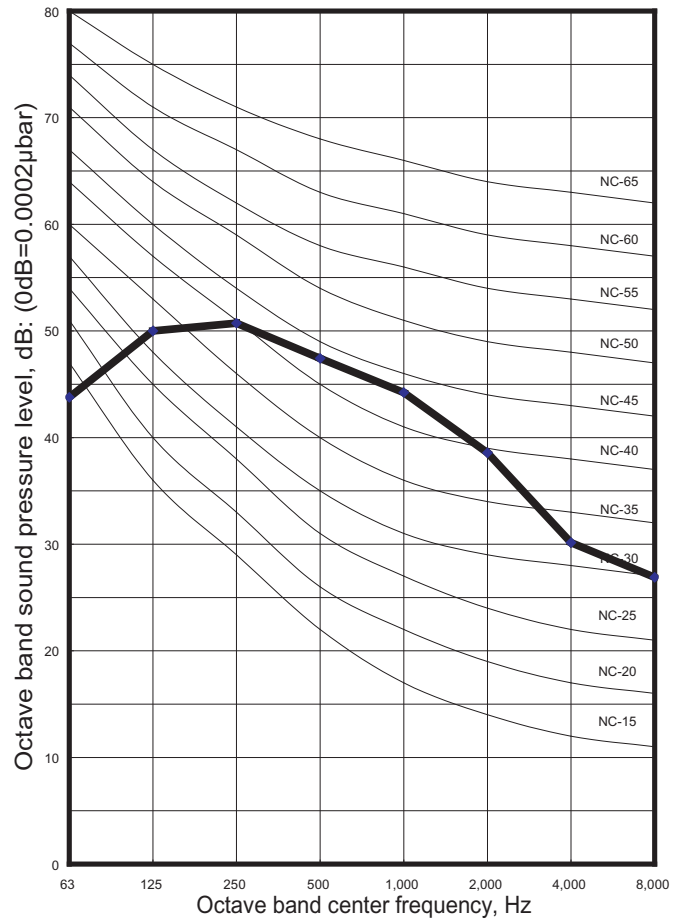

■ MODEL : AU54

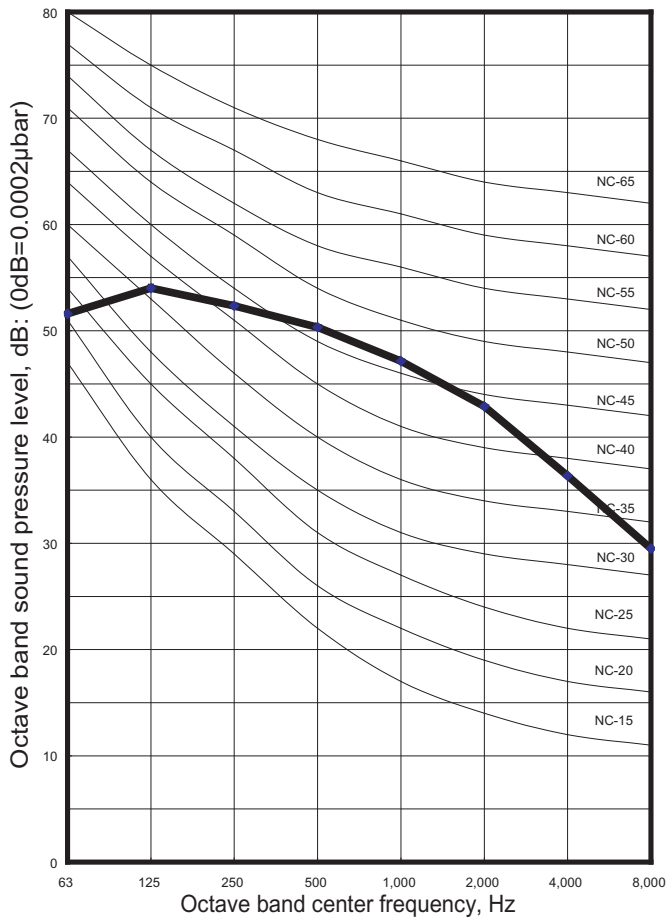

4-12-6. COMPACT WALL MOUNTED TYPE

Conditions
 Fan speed : High
 Operation mode: FAN
 Voltage : 240V

MODEL : AS7

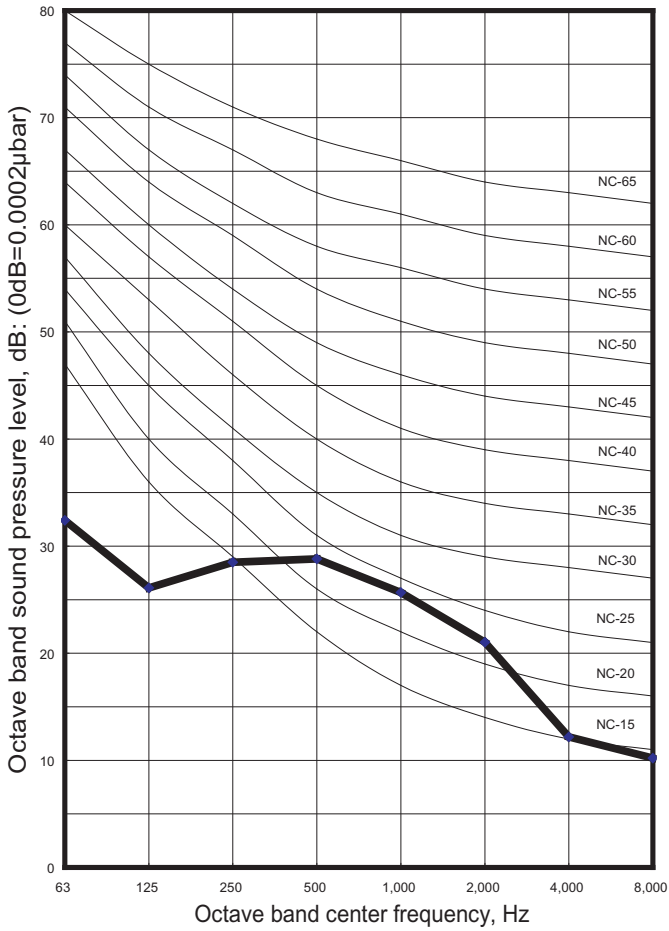

MODEL : AS9

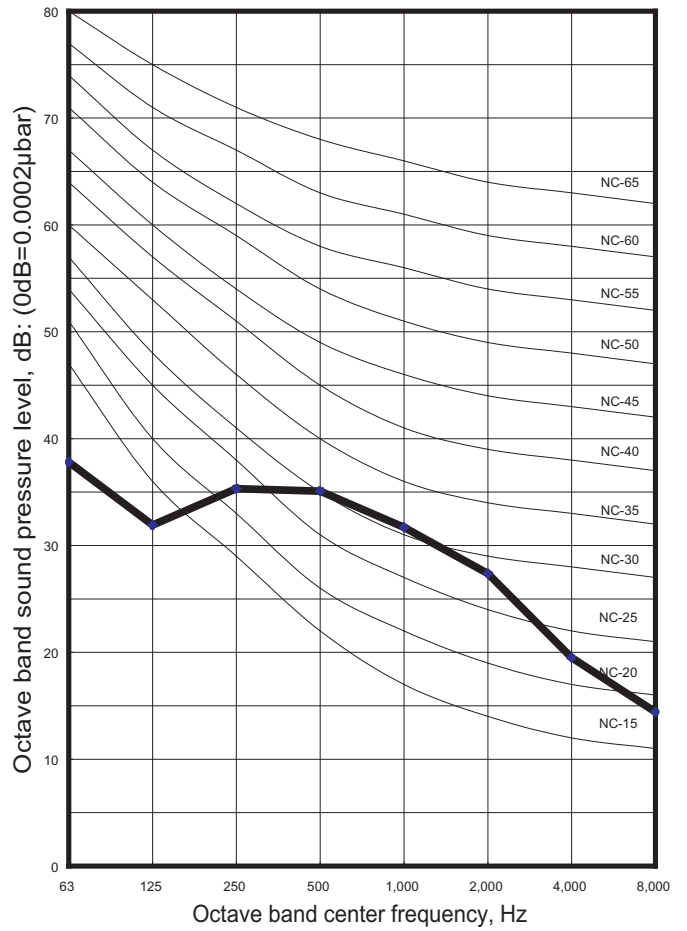

MODELS : AS12 , AS14

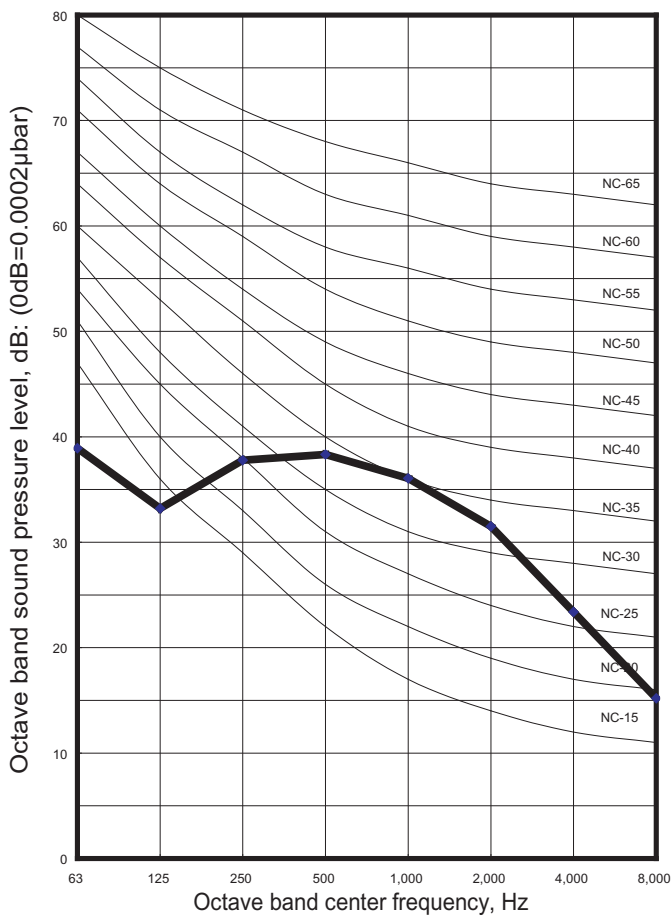

4-12-7. WALL MOUNTED TYPE

Conditions
 Fan speed : High
 Operation mode: FAN
 Voltage : 240V

MODEL : AS18

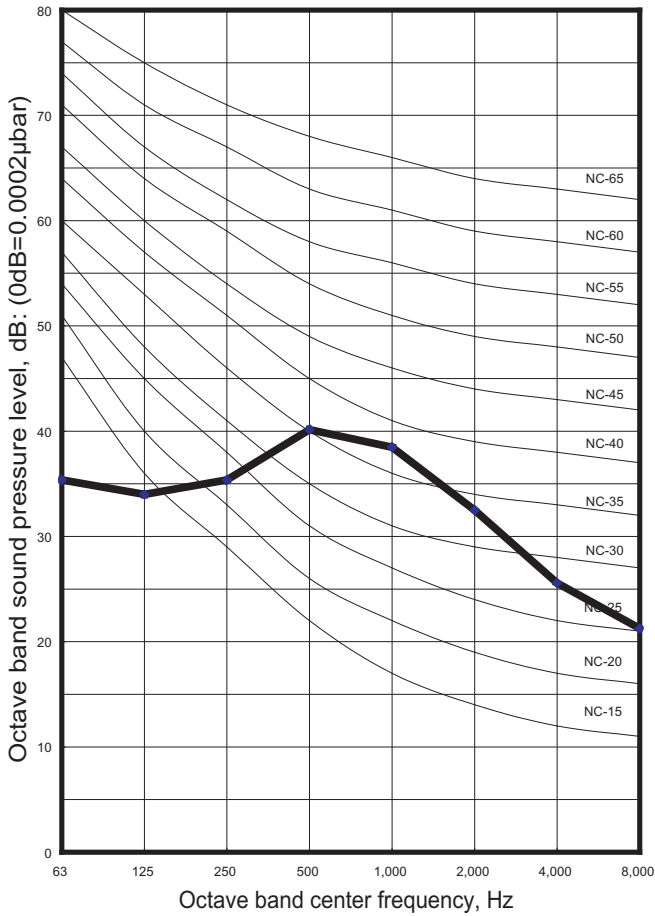

MODEL : AS24

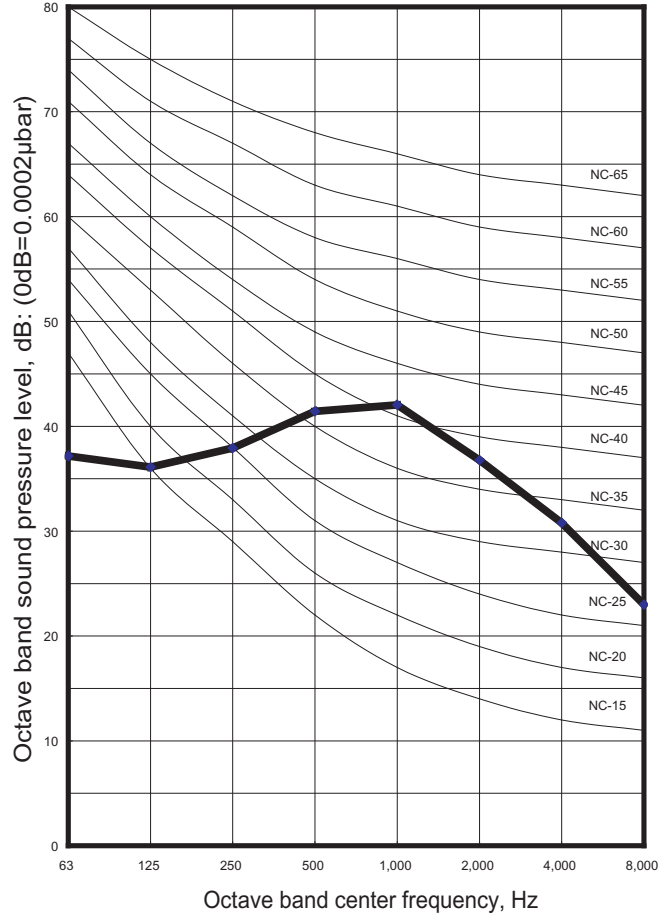

MODEL : AS30

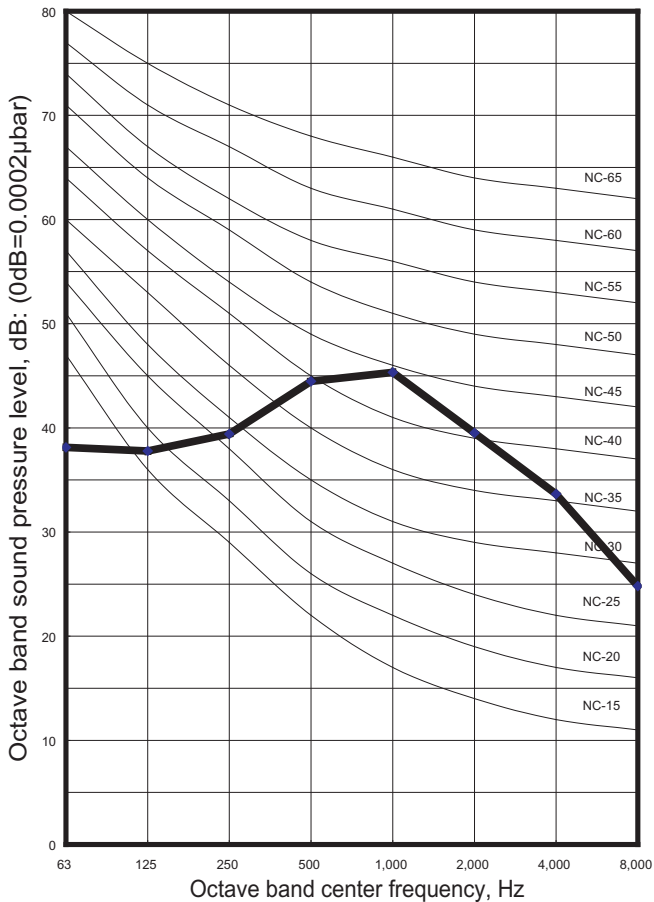

INDOOR UNIT

INDOOR UNIT

■ SOUND LEVEL CHECK POINT

- COMPACT CASSETTE TYPE
- CASSETTE TYPE

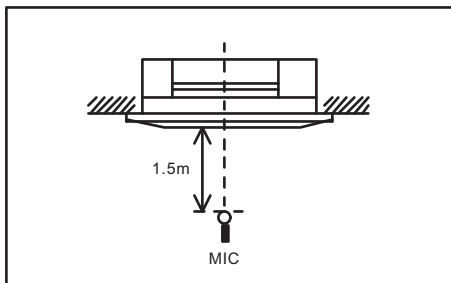

- COMPACT DUCT TYPE
- LOW STATIC PRESSURE DUCT TYPE
- DUCT TYPE

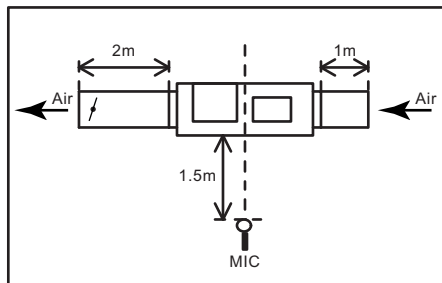

- COMPACT WALL MOUNTED TYPE
- WALL MOUNTED TYPE

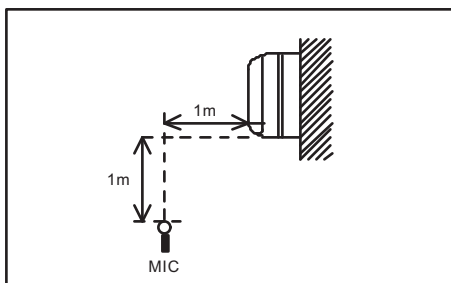

4-13. SAFETY DEVICE

MODEL NAME		P.C.B. FUSE	SIGNAL P.C.B. FUSE	FAN MOTOR THERMAL PROTECTOR	TERMINAL THERMAL FUSE	FLOAT SWITCH
COMPACT DUCT TYPE	AR7	250V 3.15A	250V 0.315A	140°C± 5°C OFF	-	-
	AR9					
	AR12					
	AR14					
	AR18					
	AR22					
LOW STATIC PRESSURE DUCT TYPE	ARXB25	250V 3.15A	250V 0.315A	150°C± 5°C OFF	-	-
	ARXB30					
DUCT TYPE	AR25	250V 3.15A	250V 0.315A	150°C± 5°C OFF	-	-
	AR30					
	AR36					
	AR45					
COMPACT CASSETTE TYPE	AU7	250V 3.15A	250V 0.315A	-	102°C	○
	AU9					
	AU12			140°C± 5°C OFF		
	AU14					
	AU18					
CASSETTE TYPE	AU20	250V 3.15A	250V 0.315A	150°C± 5°C OFF	102°C	○
	AU25					
	AU30			130°C± 5°C OFF		
	AU36					
	AU45					
	AU54					
COMPACT WALL MOUNTED TYPE	AS7	250V 3.15A	250V 0.315A	135°C± 2°C OFF	102°C	-
	AS9					
	AS12					
	AS14					
WALL MOUNTED TYPE	AS18	250V 3.15A	250V 0.315A	140°C± 5°C OFF	102°C	-
	AS24					
	AS30					

INDOOR UNIT

INDOOR UNIT

AIRSTAGE™

J SERIES

5 . INSTALLATION

5-1. PIPING DESIGN

5-1-1. PIPING METHOD

■ SUMMARY OF PIPING SYSTEM

- Heat pump type / Cooling only type

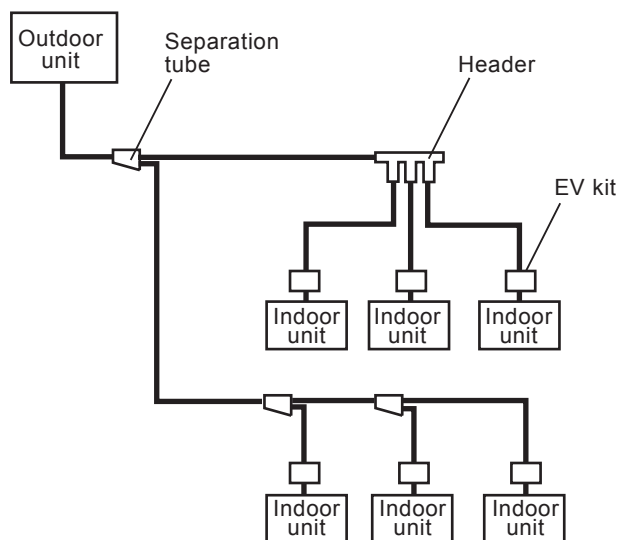

* Separation of piping : Separation tube system and header system

* Number of piping : 2 each of outdoor unit - indoor unit

■ TYPE OF PIPING SYSTEM

● Line Piping System

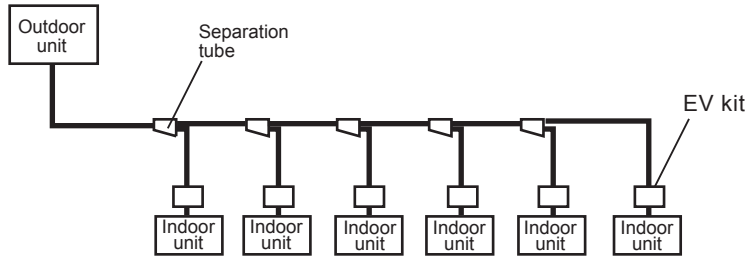

● Header Piping System

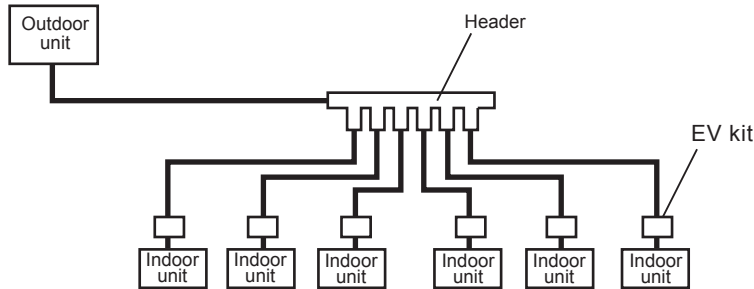

● Combined (Separation tube/Header) Piping System

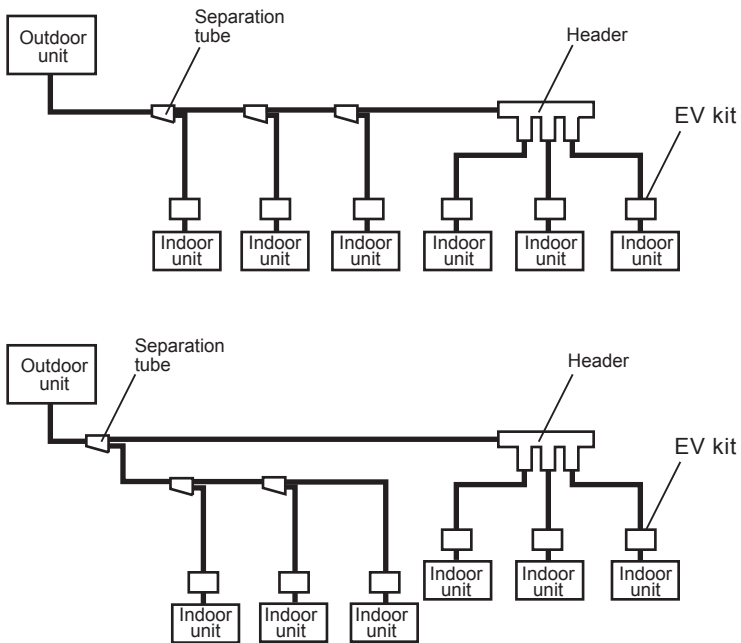

Separation after header is not allowed.

5-1-2. LIMITATIONS

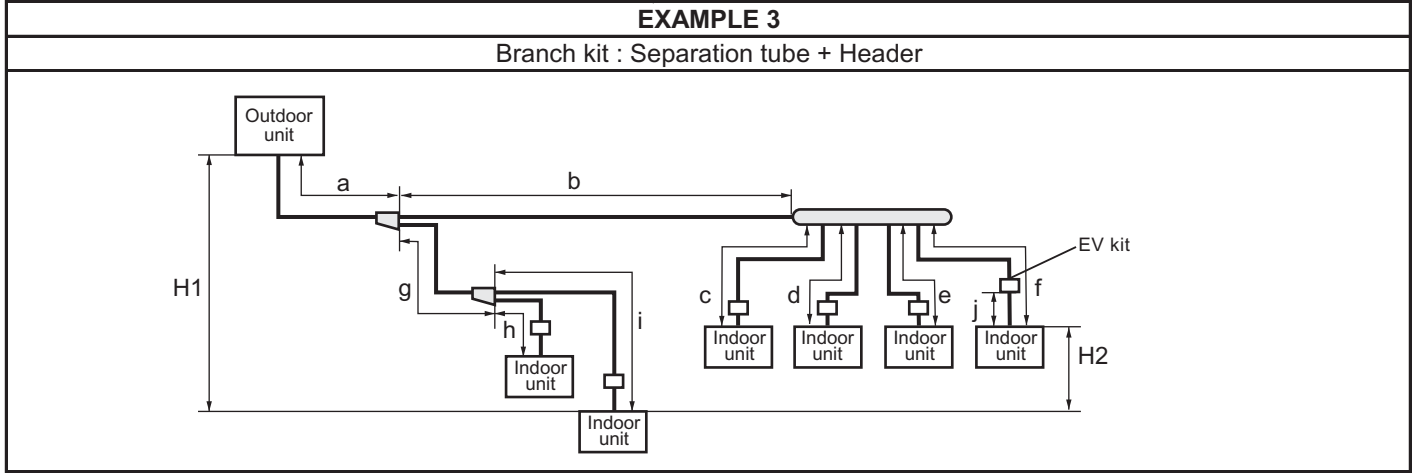
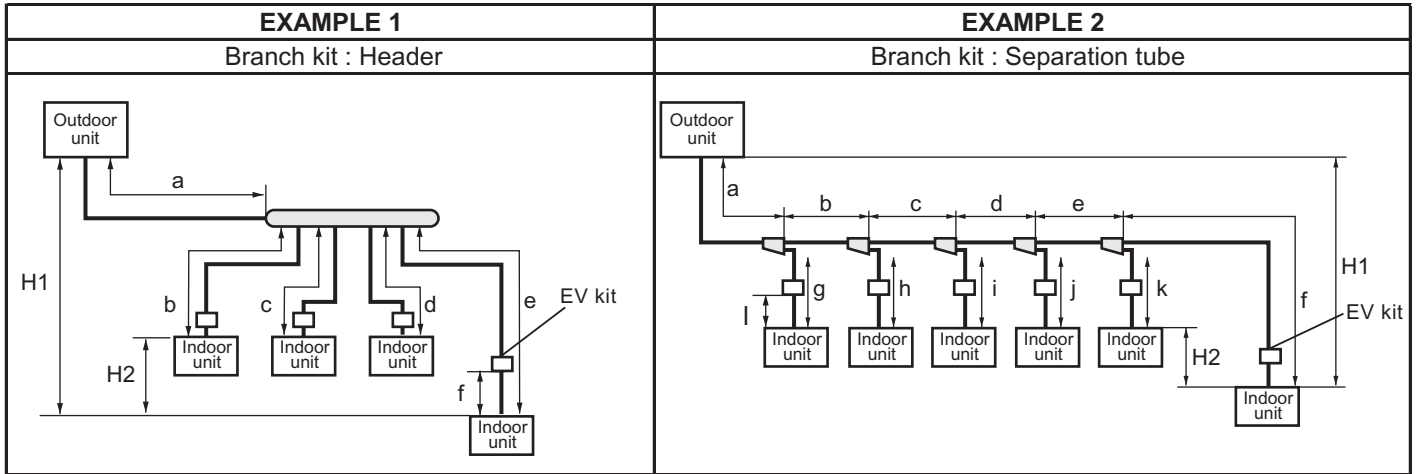

CAUTIONS

- Keep the length of straight portion of pipe between two branch kits longer than 0.5m.
- Don't use separation tube downstream of header.
- Install separation tube and header in the correct direction specified in installation manual.

Maximum allowable length (actual pipe length)		EXAMPLE 1	EXAMPLE 2	EXAMPLE 3
Between outdoor unit and the farthest indoor unit	70m	a + b	a + g	a + g + h
		a + c	a + b + h	a + g + i
		a + d	a + b + c + i	a + b + c
		a + e	a + b + c + d + j	a + b + d
		-	a + b + c + d + e + k	a + b + e
		-	a + b + c + d + e + f	a + b + f
Total pipe length	115m	a + b + c + d + e	a + b + c + d + e + f + g + h + i + j + k	a + b + c + d + e + f + g + h + i
Between outdoor unit and the 1st branch kit	60m	a		
Between the 1st branch kit and the farthest indoor unit	40m	b	g	g + h
		c	b + h	g + i
		d	b + c + i	b + c
		e	b + c + d + j	b + d
		-	b + c + d + e + k	b + e
		-	b + c + d + e + f	b + f
Between EV kit and indoor unit	1.2m	f	l	j

Note: The limit value of the shortest piping length is 7.5m.

Maximum allowable height difference		EXAMPLE 1	EXAMPLE 2	EXAMPLE 3
Between outdoor unit and indoor unit	30m	H1		
Between indoor units	AJ*A54	H2		
	AO*54			

5-1-3. PIPE SIZE

■ REFRIGERANT PIPING MATERIAL AND WALL THICKNESS

It is necessary to use seamless copper tubes for refrigerant use.
Thickness of tubes are shown in table below. The design pressure is 4.2 MPa.

Outside diameter (mm)	6.35	9.52	12.70	15.88	19.05
Material	ASTM B280; JIS H3300 C1220T-O or equivalent ¹⁾				
Wall thickness (mm)	0.8	0.8	0.8	1.0	1.2

1) : Allowable tensile stress $\geq 33 \text{ N/mm}^2$ at 125°C.

- Pipe size connected to outdoor unit.

Outdoor unit	Outside diameter (mm)	
	Liquid pipe	Gas pipe
	9.52	19.05

- Between two adjacent refrigerant branch kits.

Total model code of indoor unit	Outside diameter (mm)	
	Liquid pipe	Gas pipe
Less than 14	6.35	12.70
15 or more to 16	9.52	12.70
17 or more to 30	9.52	15.88
31 or more	9.52	19.05

- Connection pipe size of indoor unit.

Model code of indoor unit	Outside diameter (mm)	
	Liquid pipe	Gas pipe
7, 9	6.35	9.52
12, 14	6.35	12.70
18, 20, 22, 24, 25	6.35	15.88
30	9.52	15.88
36, 45, 54	9.52	19.05

5-1-4. SELECTION OF PIPE HEAT INSULATING MATERIAL

1. Always insulate the refrigerant pipe to prevent condensation and water droplets by the refrigerant pipe.
2. Decide the thickness of the heat insulating material by referring to the recommended minimum thickness in Table 1.
(For installation condition $T=30^{\circ}\text{CDB}$, humidity $\leq 70\%$, humidity $\leq 75\%$, humidity $\leq 80\%$, humidity $\leq 85\%$)
3. When the outdoor unit is installed at a higher position than the indoor unit, fill the connecting part gap with putty, etc. to prevent the dew condensation water of the valve of the outdoor unit from flowing to the indoors from the gap between the pipe and the heat insulating material.
4. Liquid pipe and gas pipe should be completely insulated with same specification and sealed.
5. In case not to insulate and not to seal refrigerant pipe completely, it will become the cause of water leak.

Table 1 Size of refrigerant pipe and recommended minimum thickness of heat insulating material
(In case a heat insulating material which thermal conductivity is equal to or less than $0.040 \text{ W}/(\text{m}\cdot\text{k})$ at 20°C is used.

Refrigerant pipe outside diameter (mm)	Recommended minimum thickness of heat insulating material (mm)			
	Relative humidity			
	$\leq 70\%$	$\leq 75\%$	$\leq 80\%$	$\leq 85\%$
6.35	8	10	13	17
9.52	9	11	14	18
12.70	10	12	15	19
15.88	10	12	16	20
19.05	10	13	16	21

※ When an ambient temperature and relative humidity exceed 30°CDB and 85% respectively, please strengthen heat insulation of refrigerant pipe. When not strengthening heat insulation of refrigerant pipe, the surface of the heat insulation may be dewed.

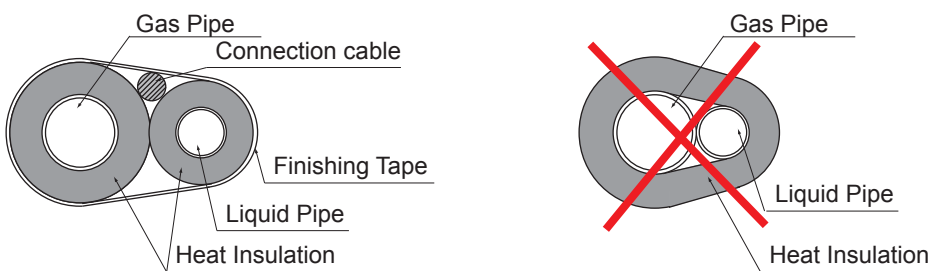

1. Make sure that pipe is covered completely by the heat insulation, not exposing to air. Inadequate heat insulation may cause condensation.
2. Do not cover heat insulation gas and liquid pipes together as above figure. It may cause condensation and capacity drop by heat loss.

5-1-5. ADDITIONAL CHARGE CALCULATION

When adding refrigerant, follow the formula below.
Add the refrigerant according to the result.

Liquid pipe diameter (mm)	9.52	6.35
Additional refrigerant (kg/m)	0.06	0.02

(1) The amount of additional charge C(kg)

$$C = \begin{array}{|c|c|} \hline \text{Total length of } \varnothing 9.52\text{mm liquid pipe} & \times 0.06 \text{ (kg/m)} \\ \hline \text{m} & \\ \hline \text{kg} & \end{array} + \begin{array}{|c|c|} \hline \text{Total length of } \varnothing 6.35\text{mm liquid pipe} & \times 0.02 \text{ (kg/m)} \\ \hline \text{m} & \\ \hline \text{kg} & \end{array} = \boxed{(1)}$$

Example : When the liquid pipe length $\varnothing 9.52\text{mm} = 35\text{m}$

$\varnothing 6.35\text{mm} = 20\text{m}$

" Additional charge for pipe length " is

$$35(\text{m}) \times 0.06(\text{kg/m}) + 20(\text{m}) \times 0.02(\text{kg/m}) = 2.50(\text{kg}) \quad (1)$$

5-1-6. EXAMPLE OF PIPING DESIGN

(1) Refrigerant system ①

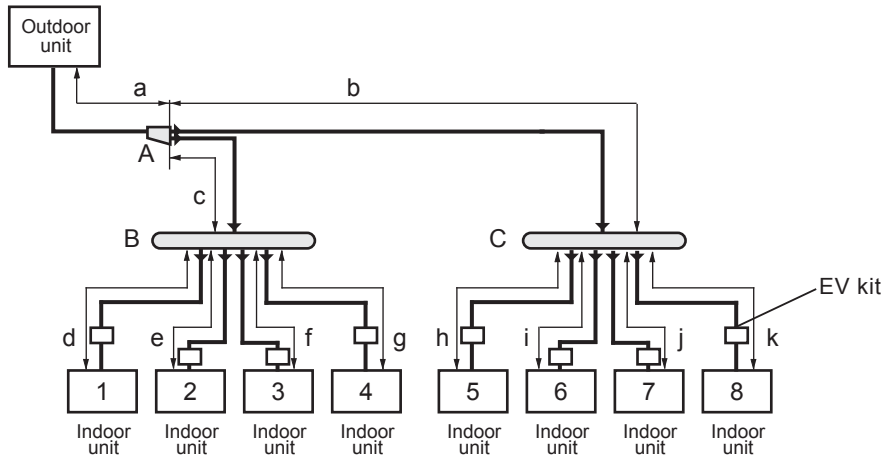

• System configuration

	1	2	3	4	5	6	7	8	Total capacity
Example 1	AR7	AR7	AR7	AR7	AR7	AR7	AR7	AR7	/
Capacity(kW)	2.15	2.15	2.15	2.15	2.15	2.15	2.15	2.15	
Example 2	AR9	AR9	AR9	AR9	AR9	AR12	AR12	AR12	/
Capacity(kW)	2.8	2.8	2.8	2.8	2.8	3.5	3.5	3.5	

Total indoor unit capacity (1 refrigerant system)

Example1 : Total capacity = 17.2 ≤ 22.8

Example2 : Total capacity = 24.5 > 22.8 ※Example 2 cannot be selected

• Selection of pipe size (Example 1)

(unit : mm)

	a	b	c	d	e	f	g
Gas Pipe	Ø19.05	Ø15.88	Ø15.88	Ø9.52	Ø9.52	Ø9.52	Ø9.52
Liquid Pipe	Ø9.52	Ø9.52	Ø9.52	Ø6.35	Ø6.35	Ø6.35	Ø6.35
Length [m] (Example)	10	10	15	5	5	10	5

	h	i	j	k
	Ø9.52	Ø9.52	Ø9.52	Ø9.52
	Ø6.35	Ø6.35	Ø6.35	Ø6.35
	5	10	10	5

● Pipe length

Maximum allowable length (actual pipe length)		Refrigerant system①	
Between outdoor unit and the farthest indoor unit	70m	a + b + h	25m
		a + b + i	30m
		a + b + j	30m
		a + b + k	25m
		a + c + d	30m
		a + c + e	30m
		a + c + f	35m
		a + c + g	30m
Total pipe length	115m	a + b + c + d + e + f + g + h + i + j + k	90m
Between outdoor unit and the 1st branch kit	60m	a	10m
Between the 1st branch kit and the farthest indoor unit	40m	b + h	15m
		b + i	20m
		b + j	20m
		b + k	15m
		c + d	20m
		c + e	20m
		c + f	25m
		c + g	20m
Between EV kit and indoor unit	1.2m	-	Within limit

Maximum allowable height difference			Refrigerant system①	
Between outdoor unit and indoor unit	30m		-	Within limit
Between indoor units	AJ*A54	15m	-	Within limit
	AO*54	5m		

● Selection of separation tube and header

	A	B	C
Model name	UTR-BP054X / UTR-BP54U	UTR-HD546U	UTR-HD546U

● Additional charge

Liquid pipe diameter	(mm)	9.52	6.35
Additional refrigerant	(kg/m)	0.06	0.02
Liquid pipe length	(m)	35	55

● Additional refrigerant

$$(0.06 \times 35) + (0.02 \times 55) = 3.20 \text{ (kg)}$$

(2) Refrigerant system ②

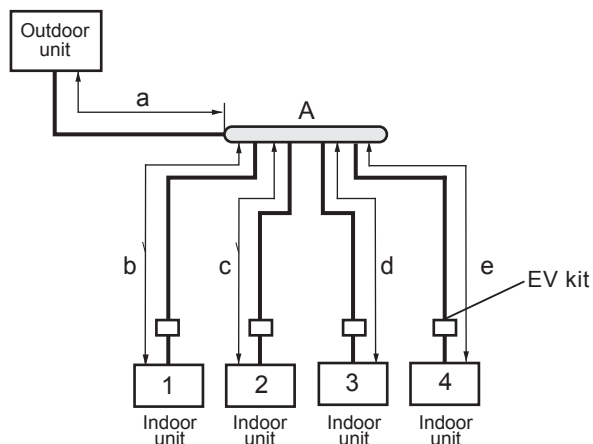

• System configuration

	1	2	3	4	Total capacity
Example 1	AR12	AR12	AR18	AR22	
Capacity(kW)	3.5	3.5	5.3	6.0	18.3
Example 2	AR18	AR22	AR22	AR22	
Capacity(kW)	5.3	6.0	6.0	6.0	23.3

Total capacity of indoor unit (1 refrigerant system)

Example1 : Total capacity = 18.3 \leq 22.8

Example2 : Total capacity = 23.3 $>$ 22.8 ※Example 2 cannot be selected.

• Selection of pipe size (Example 1)

(unit : mm)

	a	b	c	d	e
Gas Pipe	Ø19.05	Ø12.70	Ø12.70	Ø15.88	Ø15.88
Liquid Pipe	Ø9.52	Ø6.35	Ø6.35	Ø6.35	Ø6.35
Length [m] (Example)	20	15	10	10	15

• Pipe length

Maximum allowable length (actual pipe length)		Refrigerant system②	
Between outdoor unit and the farthest indoor unit	70m	a + b	35m
		a + c	30m
		a + d	30m
		a + e	35m
Total pipe length	115m	a + b + c + d + e	70m
Between outdoor unit and the 1st branch kit	60m	a	20m
Between the 1st branch kit and the farthest indoor unit	40m	b	15m
		c	10m
		d	10m
		e	15m
Between EV kit and indoor unit	1.2m	-	Within limit

Maximum allowable height difference			Refrigerant system②	
Between outdoor unit and indoor unit	30m		-	Within limit
Between indoor units	AJ*A54	15m	-	Within limit
	AO*54	5m		

• Selection of header

	A
Model name	UTR-HD546U

• Additional charge

Liquid pipe diameter	(mm)	9.52	6.35
Additional refrigerant	(kg/m)	0.06	0.02
Liquid pipe length	(m)	20	50

• Additional refrigerant

$$(0.06 \times 20) + (0.02 \times 50) = 2.20 \text{ (kg)}$$

(3) Refrigerant system ③

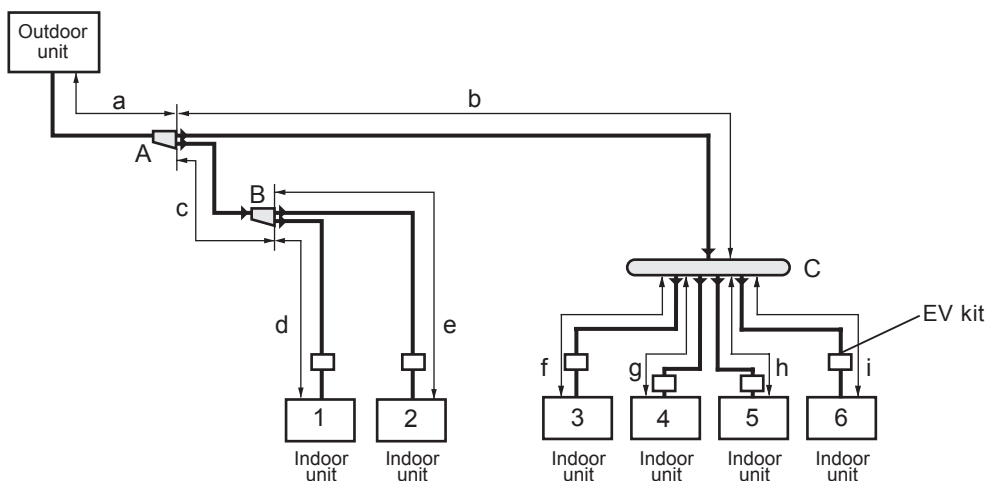

• System configuration

	1	2	3	4	5	6	Total capacity
Example 1	AS12	AS18	AR9	AR9	AR9	AR9	/
Capacity (kW)	3.5	5.4	2.8	2.8	2.8	2.8	
Example 2	AS18	AS18	AR14	AR14	AR14	AR14	/
Capacity (kW)	5.4	5.4	4.0	4.0	4.0	4.0	

Total capacity of indoor unit (1 refrigerant system)

Example 1 : Total capacity = 20.1 ≤ 22.8

Example 2 : Total capacity = 26.8 > 22.8 ※ Example 2 cannot be selected.

• Selection of pipe size (Example 1)

(unit : mm)

	a	b	c	d	e	f	g
Gas Pipe	Ø19.05	Ø19.05	Ø15.88	Ø12.70	Ø15.88	Ø9.52	Ø9.52
Liquid Pipe	Ø9.52	Ø9.52	Ø9.52	Ø6.35	Ø6.35	Ø6.35	Ø6.35
Length [m] (Example)	10	20	5	7	12	10	5

h	l
Ø9.52	Ø9.52
Ø6.35	Ø6.35
5	10

• Pipe length

Maximum allowable length (actual pipe length)		Refrigerant system③	
Between outdoor unit and the farthest indoor unit	70m	a + b + f	40m
		a + b + g	35m
		a + b + h	35m
		a + b + i	40m
		a + c + d	22m
		a + c + e	27m
Total pipe length	115m	a + b + c + d + e + f + g + h + i	84m
Between outdoor unit and the 1st branch kit	60m	a	10m
Between the 1st branch kit and the farthest indoor unit	40m	b + f	30m
		b + g	25m
		b + h	25m
		b + i	30m
		c + d	12m
		c + e	17m
Between EV kit and indoor unit	1.2m	-	Within limit

Maximum allowable height difference			Refrigerant system③	
Between outdoor unit and indoor unit	30m		-	Within limit
Between indoor units	AJ*A54	15m	-	Within limit
	AO*54	5m		

• Selection of separation tube and header

	A	B	C
Model name	UTR-BP054X / UTR-BP54U	UTR-BP054X / UTR-BP54U	UTR-HD546U

• Additional charge

Liquid pipe diameter	(mm)	9.52	6.35
Additional refrigerant	(kg/m)	0.06	0.02
Liquid pipe length	(m)	35	49

• Additional refrigerant

$$(0.06 \times 35) + (0.02 \times 49) = 3.08 \text{ (kg)}$$

5-2. WIRING DESIGN

5-2-1. WIRING SPECIFICATIONS

Use		Wire size [cross-section (mm ²)]	Remark
Power supply cable	Outdoor unit	5.0 to 8.0	H07RN-F or equivalent, Single-phase, 50HZ, 220-240V, 2Wire + Ground ※ 1
Connection cable	Indoor unit	≥ 2.5	H07RN-F or equivalent, Single-phase, 50HZ, 220-240V, 3Wire + Ground ※ 2
		≥ 1.5 (If total wire length < 50 m)	
Remote controller cable (wired, simple remote controller)		0.33	PVC sheath, Polar 3-core ※ 3
Remote controller cable (external switch controller)		0.33	PVC sheath, Polar 3-core ※ 4
Remote controller cable (group remote controller)		0.33	Shield cable, Polar 3-core ※ 5
External input cable		0.33	Twisted-pair, Polar 2-core ※ 6
External output cable		0.33	Twisted-pair, Polar 2-core ※ 6
Circuit breaker		30 (A) ※ 7	

NOTE: Installation work must be performed as outlined in installation manuals of equipments and in accordance with national wiring standards and codes.

- ※ 1 Always ground the unit.
- ※ 2 The total length of the connection cable (TL) should be shorter than or equal to 150m
If TL > 100m, keep the length of the connection cable between the units longer than 5m.
- ※ 3 10m cable attached (excluded some models). 22AWG or equivalent. Maximum length is 500m.
Use shielded cable in accordance with the standard of the country.
- ※ 4 Field supply. Use shielded cable in accordance with the standard of the country.
22AWG or equivalent.
- ※ 5 Field supply. 22AWG or equivalent.
- ※ 6 Field supply. 22AWG or equivalent. Maximum length is 25m.
Use shielded cable in accordance with the standard of the country.
- ※ 7 The capacity of the circuit breaker for leak current should be 30mA or more.

5-2-2. POWER SUPPLY & CONNECTION CABLE WIRING

■ POWER SUPPLY CABLE SPECIFICATION AND LIMITATIONS

- * Always make the air conditioner power supply a special branch circuit and provide a special breaker.
- * The capacity of the circuit breaker for leak current should be 30 mA or more.
- * The total length of the connection cable (TL) should be shorter than 150m.
- * If the total length of the connection cable exceeds 100m, keep the length of the connection cable between the units longer than 5m.

Example : Power supply cable wiring.

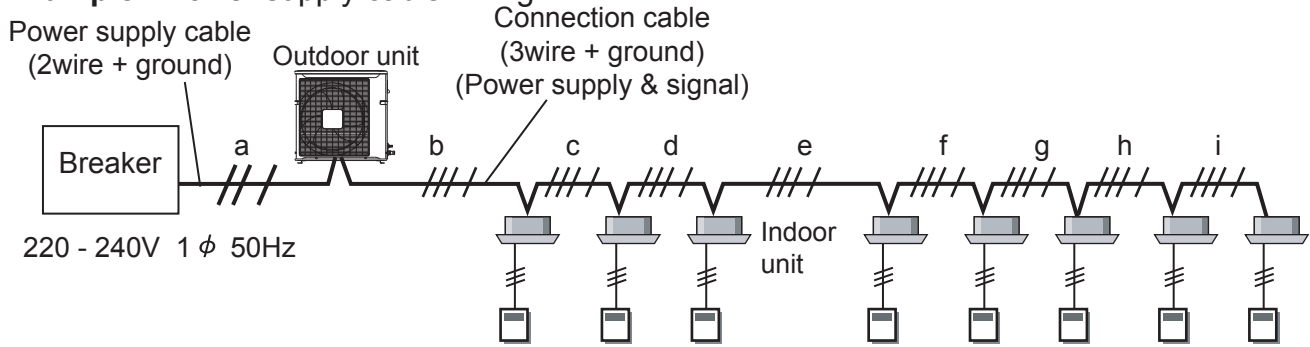

Total length of the connection cable (TL)
 $TL = b + c + d + e + f + g + h + i \leq 150m$
 IF $TL > 100m$
 $c > 5m, d > 5m, e > 5m, f > 5m, g > 5m, h > 5m, i > 5m$

WIRING PROHIBITION MATTER

The following wiring is forbidden.

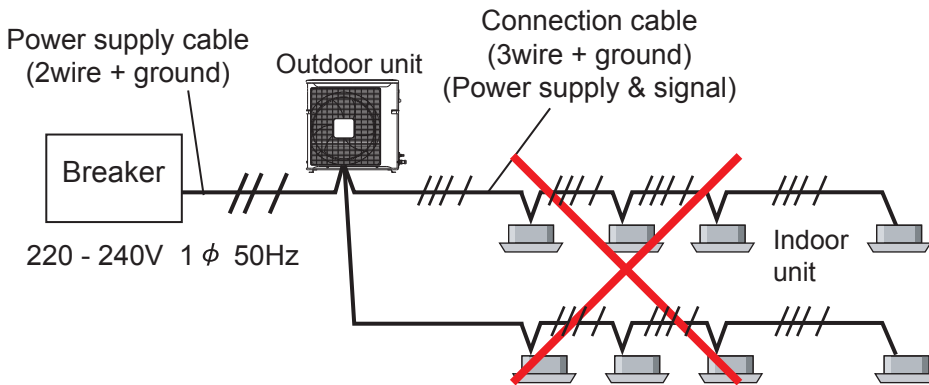

The wiring which branched from the outdoor unit to plurality and was connected to the indoor unit is prohibition.

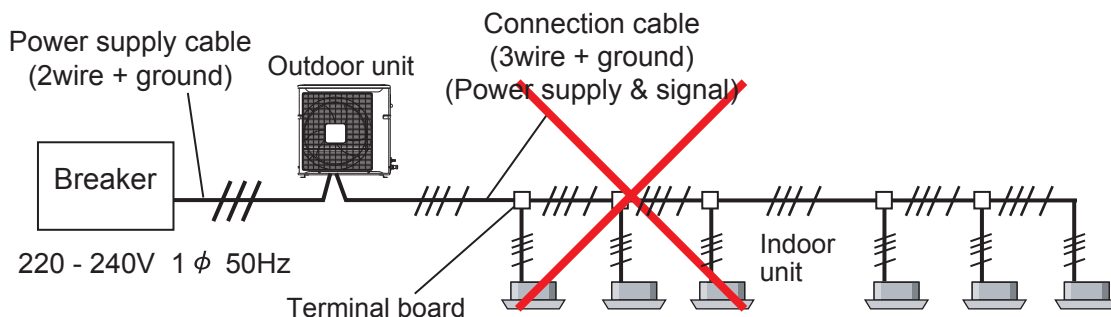

Prohibition performs wiring work, using a terminal box two or more.

5-2-3. WIRING EXAMPLE

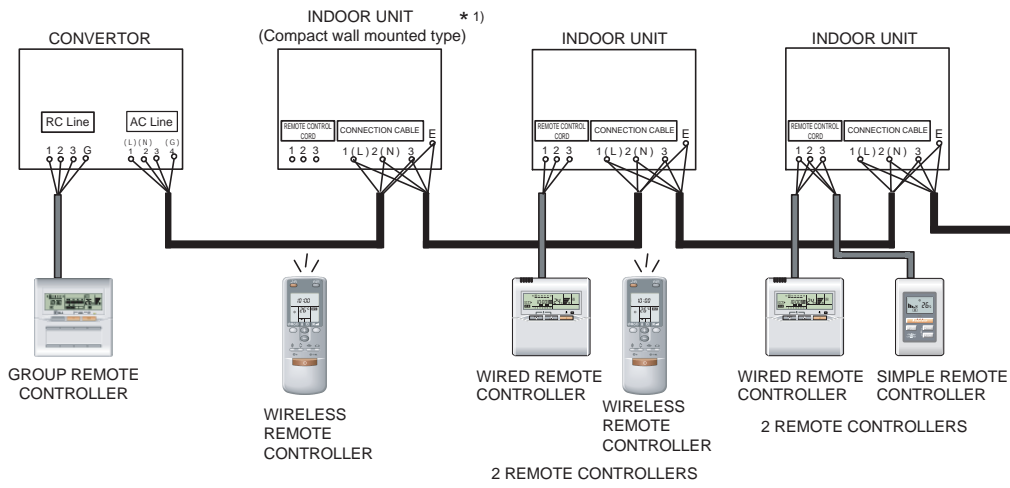
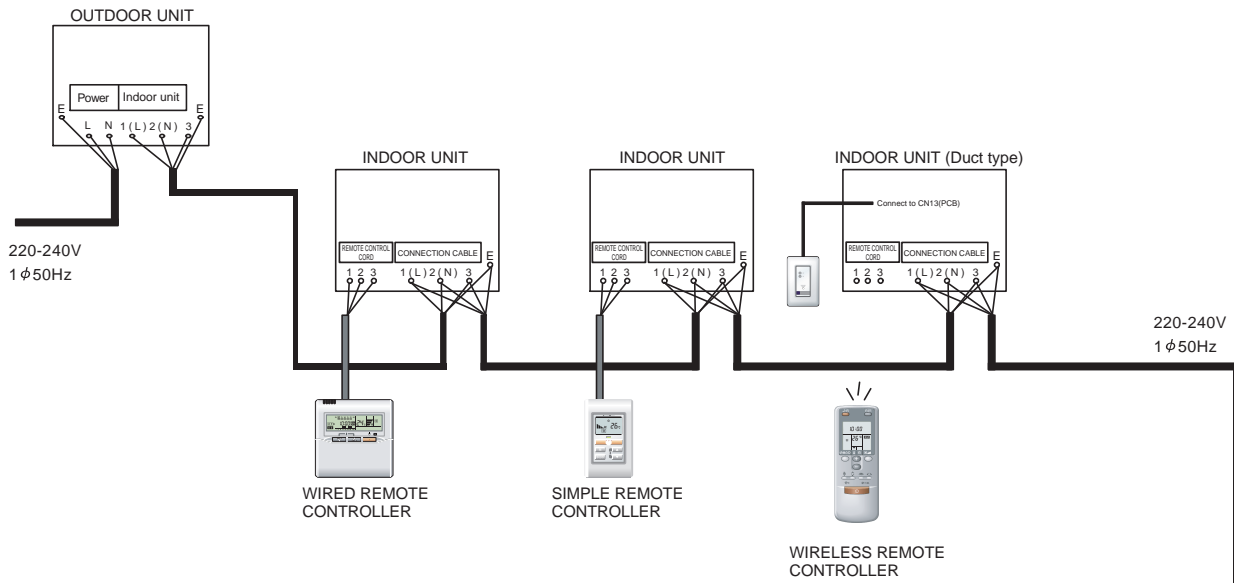

* 1) Wired and simple remote controllers are not available for compact wall mounted type indoor units.

5-3. SYSTEM SETTING

5-3-1. SYSTEM TYPE SETTING

Set the DIP switch to the corresponding system type as shown in the table.
Do not use a nonexistent switch combination.

■ WIRED, SIMPLE REMOTE CONTROLLER

(◆ . . . Factory setting)

	SW 4
◆ Heat pump	OFF
Cooling only	ON

■ PIPE LENGTH SETTING (OUTDOOR UNIT)

Depending on the pipe length, the set-up of the pipe length switch is required.
SW setting can provide the operation to supplement the loss created by the pipe length.

(◆ . . . Factory setting)

Pipe length	Recommended range of L (m)	SW 6-1	SW 6-2
◆ Standard	$7.5 \leq L < 50$	OFF	OFF
L	$50 \leq L \leq 70$	ON	ON

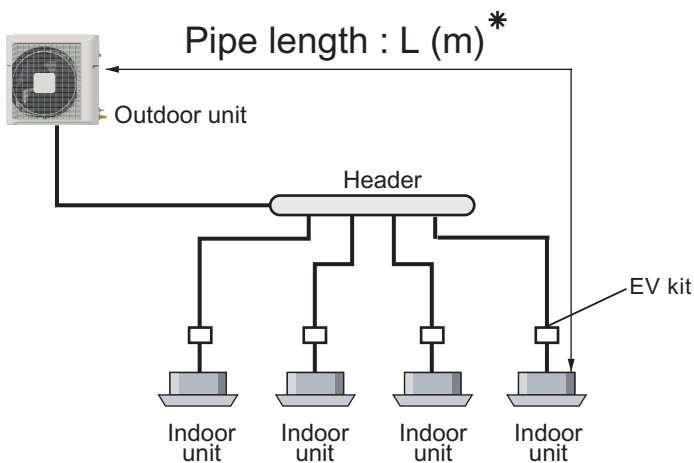

* Pipe length means the length between outdoor unit and the farthest indoor unit.

5-3-2. ADDRESS SETTING

■ SWITCHING SELECTION OF ADDRESS SETTING MODE

(1) Press and hold the "MANUAL/AUTO" button for 3 seconds.

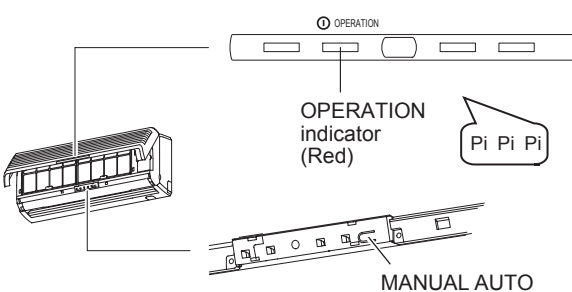

(2) Press and hold the "FAN CONTROL" and the "+" buttons. Whilst holding these 2 buttons, press the "ACL" button.

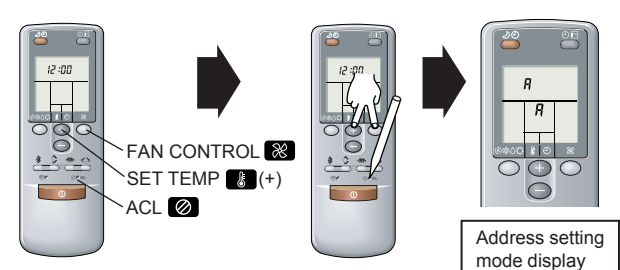

Address setting mode display

■ SELECTION AND CONFIRMATION OF CUSTOM CODE

(3) Press the "+" or "-" buttons to select the custom code that matches the setting with the indoor unit.

- By selecting the appropriate custom code, the communication between the indoor unit and the wireless RC become possible.

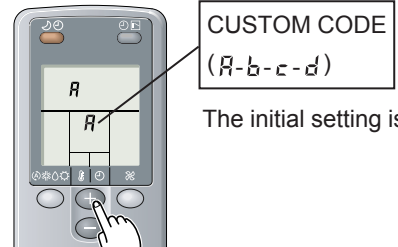

CUSTOM CODE (A-b-c-d)
The initial setting is "A"

(4) Press the "VERTICAL AIRFLOW" button to send the code to the indoor unit.

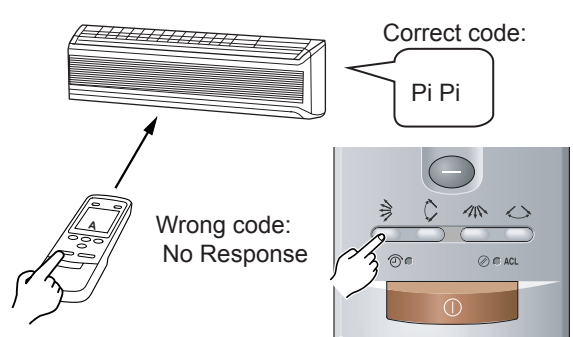

Correct code: Pi Pi

Wrong code: No Response

■ ADDRESS SETTING

(5) Press the "MASTER CONTROL" button to access the address setting mode.

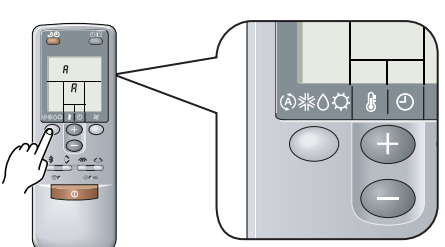

(6) Make sure the bottom number is '01'. If the number is other than '01', press the "+" or the "-" buttons to alter.

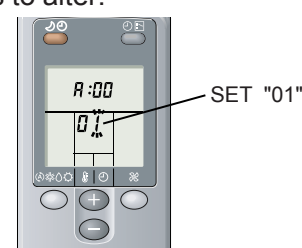

SET "01"

(7) Press the "FAN CONTROL" button to access the address data setting mode. The address data will flash once this button is pressed.

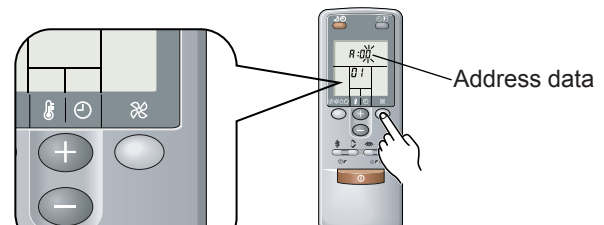

Address data

(8) Press the "+" or the "-" buttons to adjust the address. The address range is between A:00 and A:07 with A:00 always being the first address to be used.

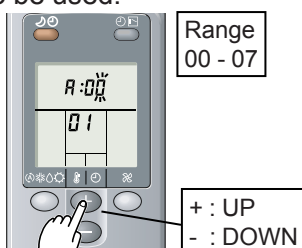

Range 00 - 07

+ : UP
- : DOWN

(9) Press the "START/STOP" button once to send the information. A beeping noise will be heard if the command is accepted.

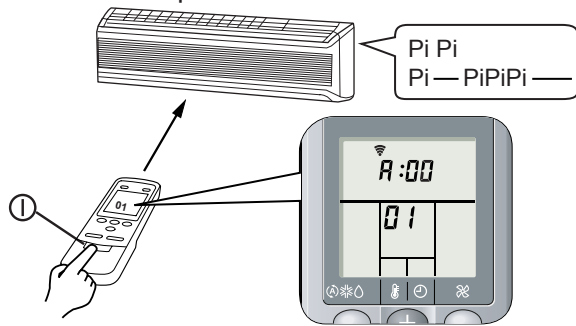

(10) Indoor unit will display the indoor unit address data number on "TIMER" (GREEN) light.

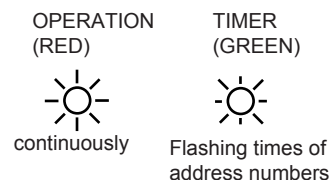

(Example) ADDRESS : 03

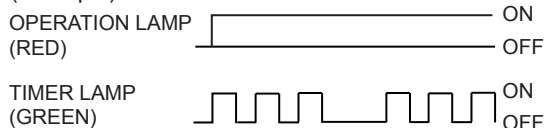

* ADDRESS 0 setting will not indicate TIMER LAMP.

■ CHECK ADDRESS SETTING

(11) Press the "SLEEP" button.

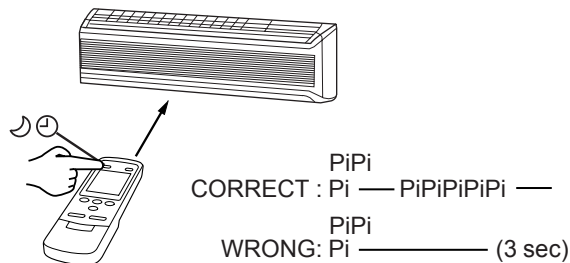

■ COMPLETION OF ADDRESS SETTING MODE

(12) Press and hold the "MANUAL/AUTO" button for 3 seconds.

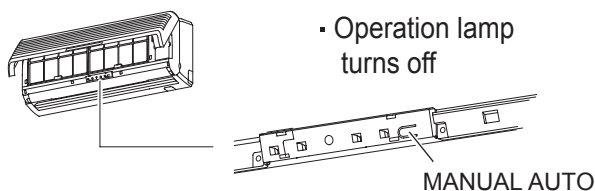

Timer lamp keep blinks the number of times of address No.

(13) Press the "ACL" button.



After pressing the ACL button, please set the custom code again if b,c,d setting.

■ SETTING UP EACH INDOOR UNIT

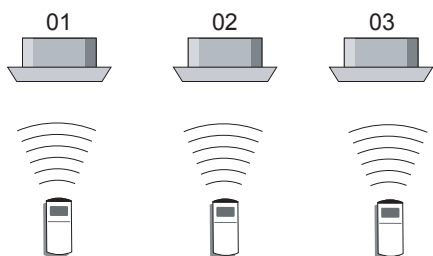

Repeat steps (1) through to (12). Steps (2) through to (4) only need to carried out if the custom code is different to the factory setting of "A".

■ RESET THE POWER AFTER SETTING UP ADDRESS OF ALL INDOOR UNITS

Important

- * If the reset is not performed, address can not be read in normally.
- * After all the addresses have been set, the circuit breaker needs to be switched off for at least 2 minutes.
After the 2 minutes has passed, power can be restored.
- * The set address is stored in the PCB and will remain in memory even when the power is turned off.
However setting address is effective after power reset.
Record the address set in the indoor unit on a label, etc., and affix the label to the unit so it can be used for after-sales service operations.

- * Address 0 setting will not indicate TIMER LAMP.
- * Once the "ACL" button is pressed on the remote controller, the MASTER CONTROL will be set in the "AUTO MODE".
Please adjust the MASTER CONTROL to either "COOLING" or "HEATING" before trying to operate the air conditioner.
- * Note : If CUSTOM CODE is set to anything other than "A" ,the remote control must be set accordingly to the INDOOR UNIT setting.

■ CUSTOM CODE SETTING

● ADJUSTING THE DIP SWITCH

① INDOOR UNIT (Except Compact Wall Mounted Type)

(◆ . . . Factory setting)

	SW5-1	SW5-2	Custom code
◆	OFF	OFF	Type A
	ON	OFF	Type B
	OFF	ON	Type C
	ON	ON	Type D

② INDOOR UNIT (Compact Wall Mounted Type)

(◆ . . . Factory setting)

	SW3-1	SW3-2	Custom code
◆	OFF	OFF	Type A
	ON	OFF	Type B
	OFF	ON	Type C
	ON	ON	Type D

● ADJUSTING THE CUSTOM CODE

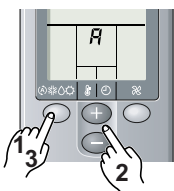

1. Press the MASTER CONTROL button for more than five seconds to start the code change.
2. Press the (+) or (-) button to select the desired code. → A → B → C → D
3. Press the MASTER CONTROL button again to end the code change.



Remote controller

5-4. FUNCTION SETTING

5-4-1. OUTDOOR UNIT

Outdoor unit			Factory setting	
DIP SW	SW1	1	Test run (Cooling)	OFF
		2	Test run (Heating)	OFF
		3	Pump down operation	OFF
		4	Forced oil recovery operation	OFF
	SW2	1	Silent operation mode	OFF
		2	Forbidden	OFF
		3	Electric current selector switch 1	OFF
		4	Electric current selector switch 2	OFF
	SW3	1	Forbidden	OFF
		2	Forbidden	OFF
		3	Forbidden	OFF
		4	Forbidden	OFF
	SW4	1	Forbidden	OFF
		2	Forbidden	OFF
		3	Forbidden	OFF
		4	Forbidden	OFF
	SW5	1	Cooling capacity shift switch 1	OFF
		2	Cooling capacity shift switch 2	OFF
		3	Heating capacity shift switch 1	OFF
		4	Heating capacity shift switch 2	OFF
	SW6	1	Pipe length switch 1	OFF
		2	Pipe length switch 2	OFF
		3	Forbidden	OFF
		4	Forbidden	OFF
	SW7	1	Forbidden (System type switch)	See table in 5-4-2
		2	Forbidden	OFF
		3	Forbidden	OFF
		4	Forbidden	OFF
	SW8	1	Forbidden	OFF
		2	Forbidden	OFF
		3	Forbidden	OFF
		4	Forbidden	OFF
SW201	1	Forbidden	OFF	
	2	Forbidden	OFF	
	3	Forbidden	OFF	
	4	Forbidden	OFF	

SWITCH POSITION

- Outdoor unit control circuit board
Main - PCB

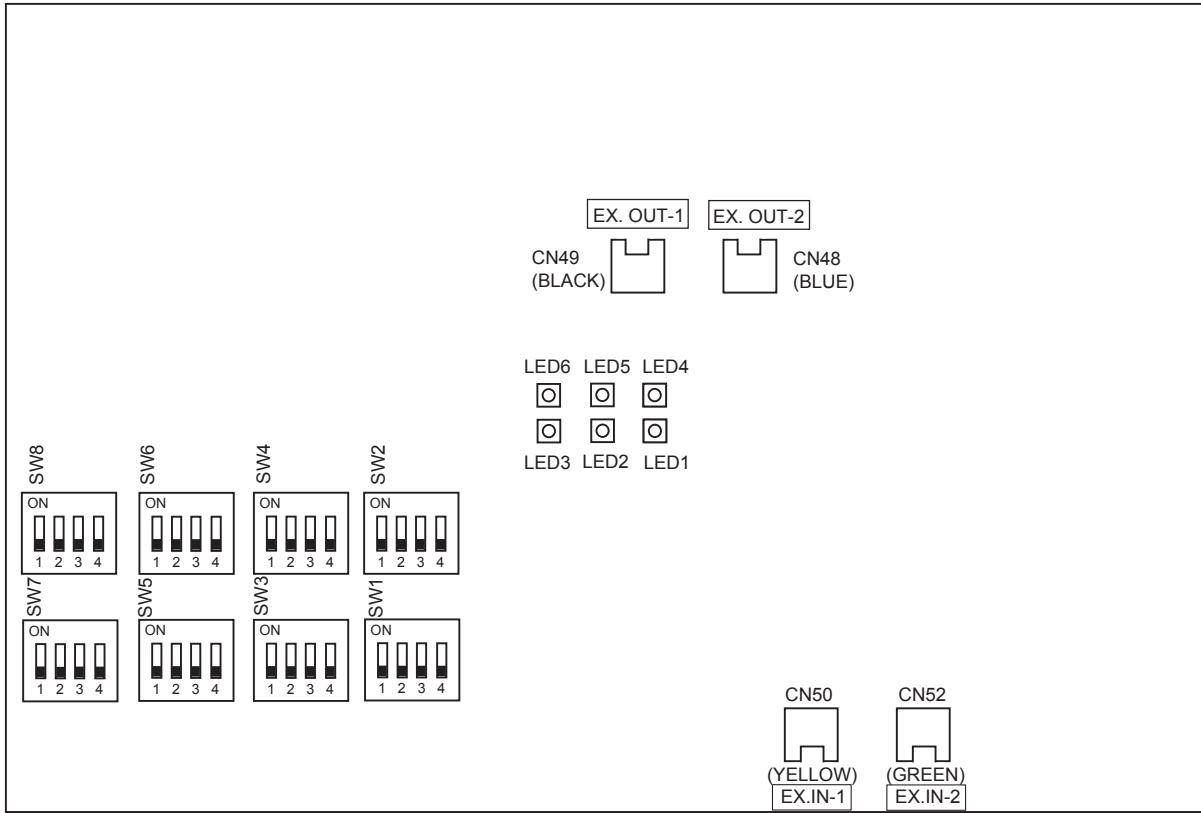

INSTALLATION

INSTALLATION

P (Filter PWB)

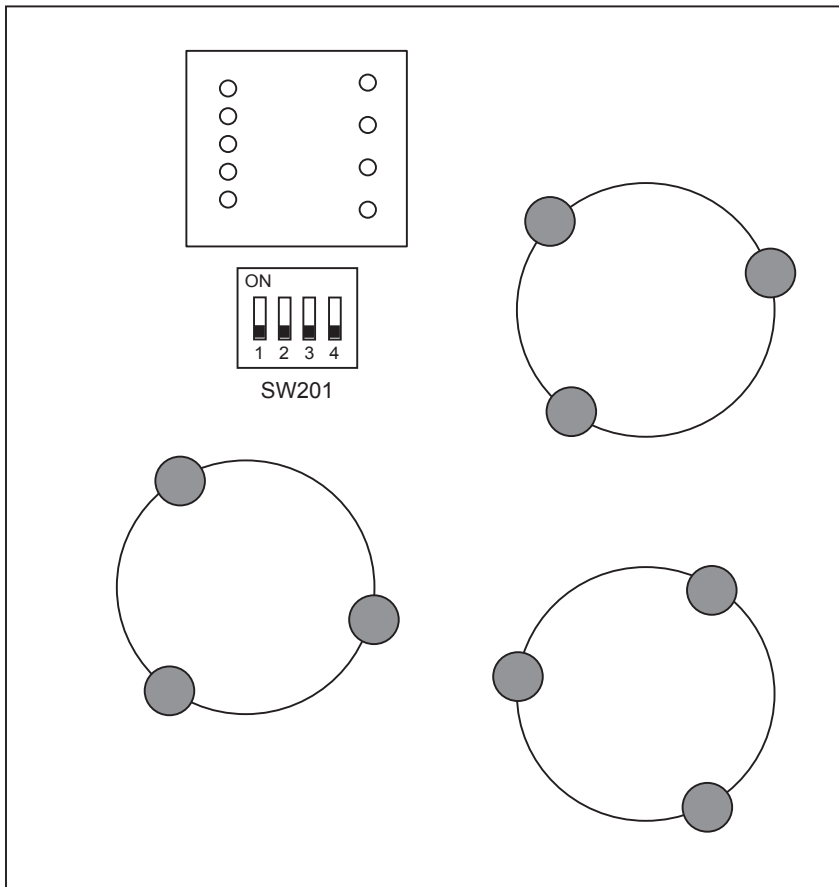

5-4-2 SWITCH FUNCTION (OUTDOOR UNIT)

■ DIP SWITCH SETTING

(1) SW1 setting

1-1 Test run

All the indoor units connected to the outdoor unit can be test-operated by DIP switch setting.

SELECTOR SWITCH FOR TEST RUN AND NORMAL OPERATION (◆ . . . Factory setting)

SW1-1	SW1-2	Test Run	Remarks
◆ OFF	OFF	Normal operation	
ON	OFF	Cooling test run	SW1-1 / SW1-2 : OFF / OFF or ON / ON → ON / OFF
OFF	ON	Heating test run	SW1-1 / SW1-2 : OFF / OFF or ON / ON → OFF / ON
ON	ON	Normal operation	

1-2 Pump down operation

PUMP DOWN OPERATION (◆ . . . Factory setting)

SW1-3	Pump down operation	Remarks
◆ OFF	Release	
ON	Operate	OFF → ON and be kept at ON position for more than 40 sec.

1-3 Forced oil recovery operation

FORCED OIL RECOVERY OPERATION (◆ . . . Factory setting)

SW1-4	Pump down operation	Remarks
◆ OFF	Release	
ON	Operate	OFF → ON and be kept at ON position for more than 10 sec.

(2) SW2 setting

2-1 Silent operation mode

Noise level can be reduced using silent operation mode when the outdoor temperature falls and high pressure decreases. (In the cooling mode only.)

SILENT OPERATION MODE (◆ . . . Factory setting)

SW2-1	Silent operation mode	Remarks
◆ OFF	Release	
ON	Operate	OFF → ON

2-2 SW 2-2 setting forbidden

2-3 SW2-3, 2-4 Electric current selector switch 1 and 2

Upper limit of electric current is set by DIP switches 2-3 and 2-4 according to the current limit.

Depending on the local power supply condition, the breaker capacity can be selected in 4 steps.

(◆ . . . Factory setting)

SW2-3	SW2-4	Circuit breaker (A)
OFF	OFF	30
OFF	ON	25
ON	OFF	20
ON	ON	15

(3) SW3 setting : Forbidden

SW3-1, 3-2, 3-3, 3-4 setting forbidden.

(4) SW4 setting : Forbidden

SW4-1, 4-2 , 4-3 , 4-4 setting forbidden.

(5) SW5 setting

5-1 Cooling capacity shift switch

The cooling and heating capacity can be changed by using this DIP switch.

(◆ . . . Factory setting)

SW5-1	SW5-2	CAPACITY SHIFT
OFF	OFF	Normal mode
OFF	ON	Save energy mode
ON	OFF	High power mode 1
ON	ON	High power mode 2

5-2 Heating capacity shift switch

(◆ . . . Factory setting)

SW5-3	SW5-4	CAPACITY SHIFT
OFF	OFF	Normal mode
OFF	ON	Save energy mode
ON	OFF	High power mode 1
ON	ON	High power mode 2

(6) SW6 setting

6-1 SW 6-1, 6-2 Pipe length switch

SW setting can provide the operation to supplement the loss created by the pipe length.

(◆ . . Factory setting)

SW 6 - 1	SW 6 - 2	Pipe length	Recommended rang of L (m)
OFF	OFF	Standard	$7.5 \leq L < 50$
ON	ON	Pipe length L	$50 \leq L \leq 70$

The pipe lengths shown here are one of the standards. It may differ depending on the system.

6-2 SW 6-3, 6-4 setting forbidden

(7) SW7 setting

7-1 System type switch (Never change at the site)

This switch was set corresponding to the system type before shipment.

SYSTEM TYPE SWITCH (◆ . . . Factory setting)

SW7-1	System type
OFF	Heat pump
ON	Cooling only

7-2 SW 7-2, 7-3, 7-4 setting forbidden.

(8) SW8 setting : Forbidden

SW8-1, 8-2, 8-3, 8-4 setting forbidden.

(9) SW201 setting : Forbidden

SW 201-1, 201-2, 201-3, 201-4 setting forbidden

EXTERNAL INPUT AND OUTPUT

Connector	Input	Output
CN48	----	Operation Display (DC12V)
CN49	----	Error Display (DC12V)
CN50	OFF: Remote controller priority ON: External input priority	----
CN52	Cool or Heat select switch	----

5-4-3. INDOOR UNIT

Indoor unit			Factory setting	
DIP SW	SW1	1	Forbidden	OFF
		2	Forbidden	OFF
		3	Room temp correct coefficient of heating 1	OFF
		4	Room temp correct coefficient of heating 2	OFF
	SW2	1	Room temp correct coefficient of cooling	OFF
		2	Forbidden	OFF
		3	Forbidden	OFF
		4	Auto restart validity / invalidity	OFF
	SW3	1	Forbidden (Indoor unit fan speed switch1)	See table in 5-4-4
		2	Forbidden (Indoor unit fan speed switch2)	See table in 5-4-4
		3	Forbidden (Indoor unit fan speed switch3)	See table in 5-4-4
		4	External input select edge / pulse	OFF
	SW4	1	Forbidden (Indoor unit model code)	See table in 5-4-4
		2	Forbidden (Indoor unit model code)	See table in 5-4-4
		3	Forbidden (Indoor unit model code)	See table in 5-4-4
		4	Forbidden (Indoor unit model code)	See table in 5-4-4
	SW5	1	Wireless remote controller custom code switch 1	OFF
		2	Wireless remote controller custom code switch 2	OFF
		3	Forbidden	OFF
		4	Draft prevention setting switch	OFF

INSTALLATION

INSTALLATION

■ SWITCH POSITION

● Indoor unit control circuit board

For AU / AR types indoor unit

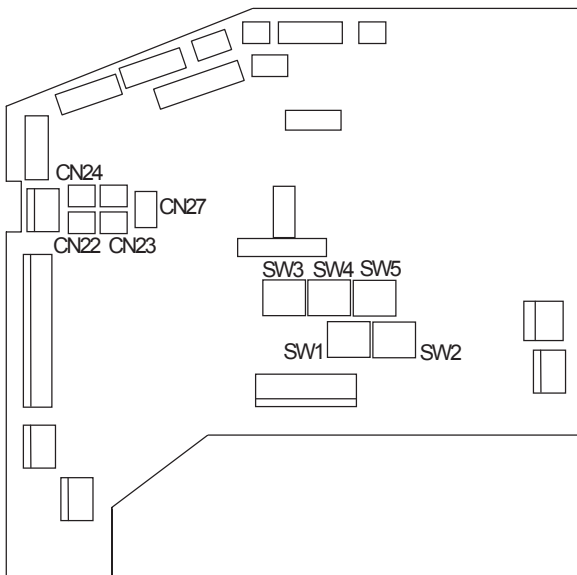

For AS type indoor unit

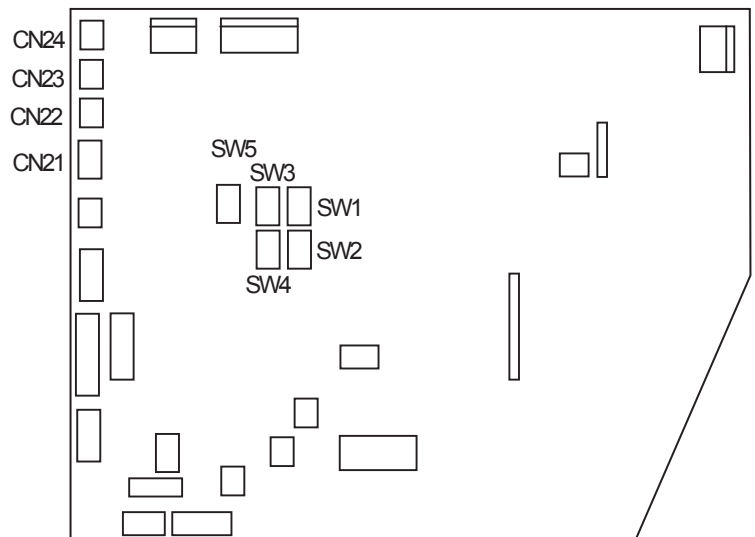

5-4-4 SWITCH FUNCTION (INDOOR UNIT)

■ DIP SWITCH SETTING

(1) SW1 setting

1-1 SW 1-1, 1-2 setting forbidden

1-2 Room temperature correct coefficient of heating.

Decide the heating temperature correct coefficient value for room temperature thermistor.

The overall room temperature increases when a larger coefficient value is used.

HEATING TEMPERATURE CORRECTION (◆ . . . Factory setting)

SW1-3	SW1-4	Coefficient value
OFF	OFF	+2 deg
ON	OFF	- 2 deg
OFF	ON	0 deg
ON	ON	+ 4 deg

(2) SW2 setting

2-1 Room temperature correct coefficient of cooling.

Decide the cooling temperature correct coefficient value for room temperature thermistor.

The overall room temperature decreases when a larger coefficient value is used.

COOLING TEMPERATURE CORRECTION (◆ . . .Factory setting)

SW2-1	Coefficient value
OFF	0 deg
ON	+ 2 deg

2-2 SW 2-2, 2-3 setting forbidden

2-3 Auto restart validity / invalidity.

Control the auto restart function by turning this switch ON/OFF.

AUTO RESTART SETTING (◆ . . . Factory setting)

SW2-4	Auto restart
◆ OFF	Invalidity
ON	Validity

(3) SW3 setting (Never change at the site)

3-1 Indoor unit fan speed switch

This switch can select fan speed corresponding to each model.

Cassette type

	AU20	AU25	AU30	AU36	AU45	AU54
SW3-1	ON	OFF	OFF	OFF	ON	OFF
SW3-2	ON	ON	OFF	ON	OFF	OFF
SW3-3	ON	ON	ON	OFF	OFF	OFF

Wall mounted type

	AS18	AS24	AS30
SW3-1	OFF	OFF	ON
SW3-2	OFF	ON	ON
SW3-3	ON	ON	ON

Other model (Default)

SW3-1	OFF
SW3-2	OFF
SW3-3	OFF

3-2 SW 3-4 setting

This switch is used to select the format of external input command as shown in the table below.

(◆ . . . Factory setting)

SW3-4	External input select
◆ OFF	Edge
ON	Pulse

(4) SW4 setting (Never change at the site)

This switch for changing the model code information of indoor unit PCB.

INDOOR UNIT MODEL CODE

Capacity	54	45	36	30	25(24)	20(22)	18	14	12	9	7
SW4-1	OFF	ON	OFF	ON	OFF	ON	OFF	ON	OFF	ON	OFF
SW4-2	ON	OFF	OFF	ON	ON	OFF	OFF	ON	ON	OFF	OFF
SW4-3	OFF	OFF	OFF	ON	ON	ON	ON	OFF	OFF	OFF	OFF
SW4-4	ON	ON	ON	OFF	OFF	OFF	OFF	OFF	OFF	OFF	OFF

(5) SW5 setting

5-1 Wireless remote controller custom code switch

Limit the type of infrared control signal which the indoor unit is controlled, in order to prevent misoperation of indoor unit due to signal from other wireless remote controller.

REMOTE CONTROLLER CUSTOM CODE SWITCH (◆ ... Factory setting)

SW5-1	SW5-2	Custom code
OFF	OFF	Type A
ON	OFF	Type B
OFF	ON	Type C
ON	ON	Type D

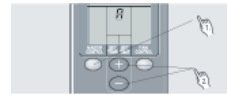

1. Press the MASTER CONTROL button for more than five seconds to start the code change.
2. Press the (+) or (-) button to select the desired code. $\rightarrow A \rightarrow B \rightarrow C \rightarrow D$
3. Press the MASTER CONTROL button again to end the code change.



5-2 SW 5-3 setting forbidden

5-3 Draft prevention setting switch (only for cassette type)

Set the flap angle of cassette type unit.

DRAFT PREVENTION SWITCH (◆ ... Factory setting)

SW5-4	Flap angle
OFF	Normal position
ON	Draft prevention position

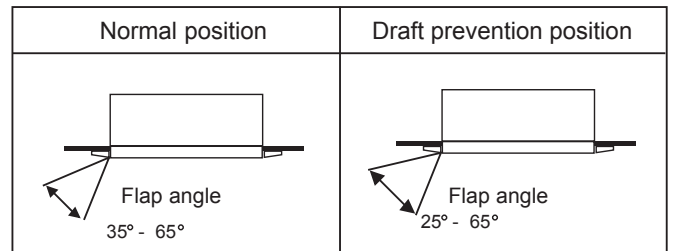

An air flow direction, by moving the flap angle horizontally, it can prevent that a cold wind directly hits.

* If air conditioning cooling operation is performed in long long time and a humid place, there is a possibility that water drop may hang down from q blow-off mouth.

■ EXTERNAL INPUT AND OUTPUT

Connector	Indoor unit type	Input	Output	Remarks
CN21	Wall mounted	CONTROL INPUT (OPERATION / STOP)	-----	See 5-5-1 for details
CN27	Other type			
CN22	All types	-----	OPERATION DISPLAY (DC12V)	
CN23			ERROR DISPLAY (DC12V)	
CN24			INDOOR UNIT FAN STATUS DISPLAY(DC12V)	

5-4-5. INDOOR UNIT (COMPACT WALL MOUNTED TYPE)

Indoor unit			Factory setting	
DIP SW	SW1	1	Forbidden (Indoor unit fan speed switch1)	See table in 5-4-6
		2	Forbidden (Indoor unit fan speed switch2)	See table in 5-4-6
		3	Forbidden (Indoor unit model code)	See table in 5-4-6
		4	Forbidden (Indoor unit model code)	See table in 5-4-6
	SW2	1	Forbidden	OFF
		2	Forbidden	OFF
		3	Auto restart validity / invalidity	OFF
		4	Forbidden	OFF
Jumper wire	JM 1	Wireless remote controller custom code	Connect	
	JM 2	Wireless remote controller custom code	Connect	

■ SWITCH POSITION

- Compact wall mounted type indoor unit control circuit board

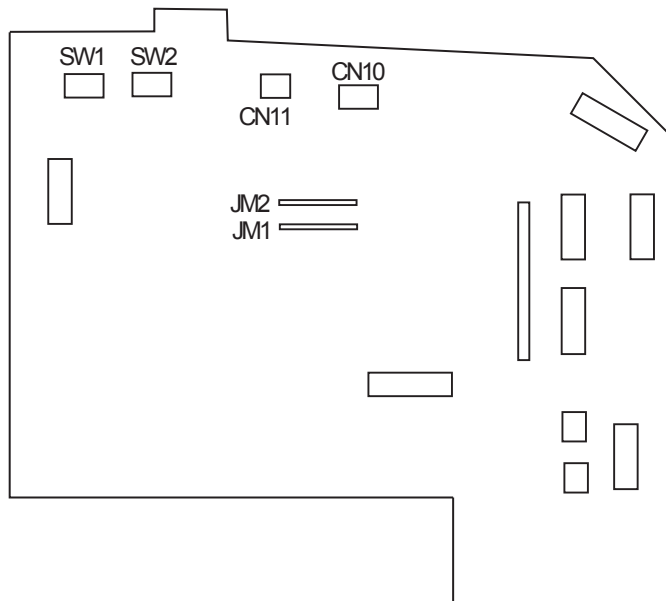

5-4-6 SWITCH FUNCTION (COMPACT WALL MOUNTED TYPE)

■ DIP SWITCH SETTING

(1) SW1 setting (Never change at the site)

1-1 Fan speed setting switch

The fan speed corresponding to each model is set with the switch.

	AS7	AS9	AS12	AS14
SW1-1	OFF	ON	OFF	ON
SW1-2	OFF	OFF	ON	ON

1-2 Model code setting switch

The model code information corresponding to each model is provided with the switch.

	AS7	AS9	AS12	AS14
SW1-3	OFF	ON	OFF	ON
SW1-4	OFF	OFF	ON	ON

(2) SW2 setting

2-1 SW2-1, 2-2, 2-4 setting forbidden

2-2 Auto restart validity / invalidity.

Control the auto restart function by turning this switch ON/OFF.

AUTO RESTART SETTING (◆ . . . Factory setting)

SW2-3	Auto restart
◆ OFF	Invalidity
ON	Validity

■ JUMPER WIRE

Wireless remote controller custom code switch

Limit the type of infrared control signal which the indoor unit is controlled, in order to prevent misoperation of indoor unit due to signal from other wireless remote controller.

REMOTE CONTROLLER CUSTOM CODE SWITCH

(◆ . . . Factory setting)

JM1	JM2	Custom code
Connect	Connect	Type A
Disconnect	Connect	Type B
Connect	Disconnect	Type C
Disconnect	Disconnect	Type D

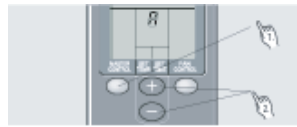

1. Press the MASTER CONTROL button for more than five seconds to start the code change.
2. Press the (+) or (-) button to select the desired code.

3. Press the MASTER CONTROL button again to end the code change.



■ EXTERNAL INPUT AND OUTPUT

Connector	Input	Output	Remarks
CN10	CONTROL INPUT (OPERATION / STOP)	_____	See 5-5-2 for details
CN11	_____	OPERATION DISPLAY (DC12V)	

5-4-7 WIRED, SIMPLE REMOTE CONTROLLER

Wired remote controller			Factory setting
DIP SW	1	Dual remote controller setting	ON
	2	Dual remote controller setting	OFF
	3	Forbidden	OFF
	4	Model setting	OFF
	5	Auto changeover setting	OFF
	6	Memory backup setting	OFF

Simple remote controller			Factory setting
DIP SW	1	Dual remote controller setting	ON
	2	Dual remote controller setting	OFF
	3	Forbidden	OFF
	4	Model setting	OFF
	5	Auto changeover setting	OFF
	6	Forbidden	OFF

SWITCH POSITION

Wired remote controller

Front case (back side)

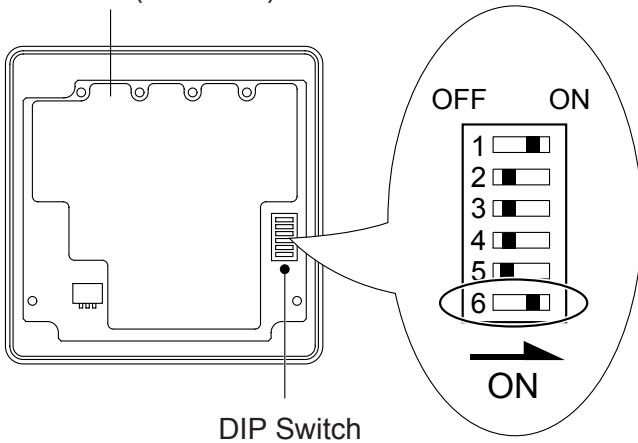

Simple remote controller

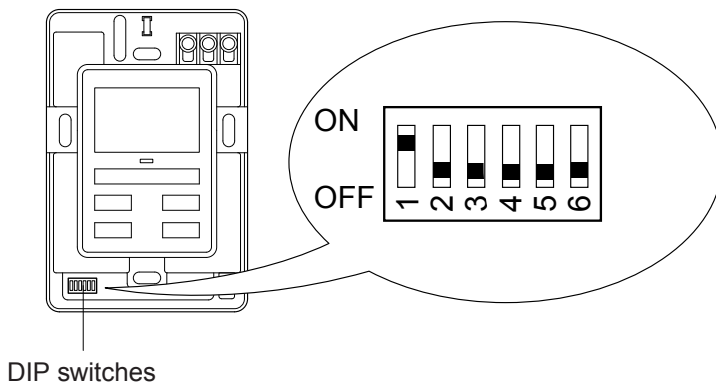

5-4-8. SWITCH FUNCTION (WIRED, SIMPLE REMOTE CONTROLLER)

Always set the DIP SW before turning the power on.

■ DIP SWITCH SETTING

(1) Dual remote controller setting

Two separate remote controllers can be used to operate the same indoor unit.

Set the Dip SW 1,2 according to the following table.

(◆ . . . Factory setting)

Number of remote controllers	Master unit		Slave unit	
	Dip SW 1	Dip SW 2	Dip SW 1	Dip SW 2
◆ 1 (Normal)	ON	OFF	—	—
2 (Dual)	OFF	OFF	ON	ON

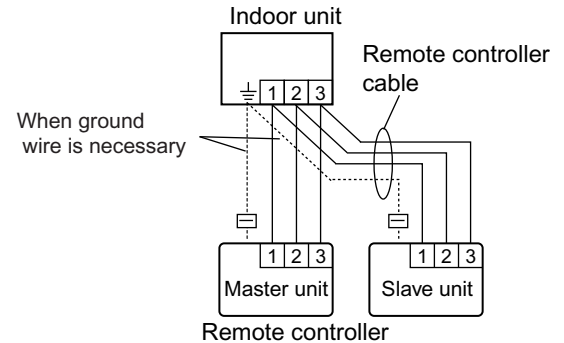

(2) SW 3 setting forbidden

(3) Model setting

(◆ . . . Factory setting)

SW4	Model setting
OFF	Heat Pump
ON	Cooling only

(5) Auto change over validity/invalidity

Selecting auto change over validity/invalidity. Never turn it ON in the case of heat pump model.

(◆ . . . Factory setting)

SW5	Auto change over
OFF	Invalidity ※1
ON	Validity ※2

※1 : Set to OFF for "HEAT PUMP TYPE".

※2 : Set to ON for "COOLING ONLY TYPE".

(6) Memory backup switch

Set to ON to use batteries for the memory backup. If batteries are not used, all of the settings stored in memory will be deleted if there is a power failure.

※This function is available for wired remote controller only. Setting for simple remote controller is forbidden.

(◆ . . . Factory setting)

SW6	Battery backup
OFF	Invalidity
ON	Validity

5-4-9. GROUP REMOTE CONTROLLER

Group remote controller			Factory setting
DIP SW	1	Memory backup setting	OFF
	2	Forbidden	OFF

■ SWITCH POSITION

● Group remote controller

Front case (back side)

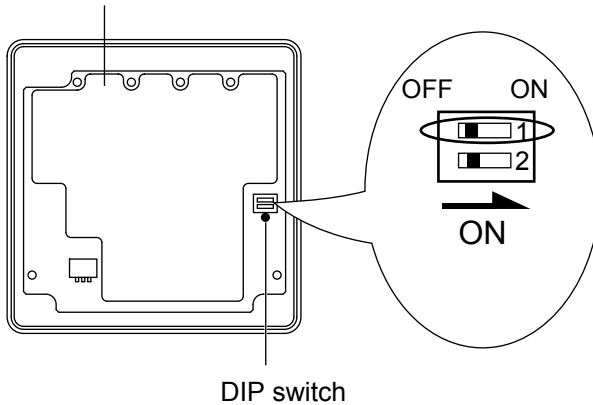

DIP switch

5-4-10 SWITCH FUNCTION (GROUP REMOTE CONTROLLER)

■ DIP SWITCH SETTING

(1) SW1 setting

Set SW1 to ON to enable the memory backup.

If there is a power failure when the memory backup is enabled, the setting stored in the memory will be saved.

(◆ . . . Factory setting)

SW1	Memory backup
◆ OFF	Invalidity
ON	Validity

(2) SW2 setting : Forbidden

5-5.EXTERNAL INPUT & OUTPUT

5-5-1. INDOOR UNIT

(1) Control input (Operation/Stop)

Indoor unit can be operated or stopped by using indoor unit PCB CN 21 (Wall mounted type) or CN27 (other types).

① Input select

Dip SW3-4	Input select
OFF	Edge
ON	Pulse

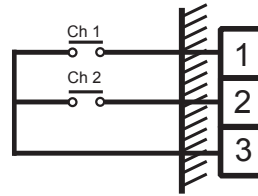

*1) For Wall mounted type.
*2) For other types

CN 21(RED) *1)
or
CN 27(RED) *2)

② In the case of "Edge" input

CONNECTOR	INPUT SIGNAL	COMMAND
Ch1 of CN21 ^{*1)} (RED) or CN27 ^{*2)} (RED)	OFF → ON	Operation
	ON → OFF	Stop

Open circuit voltage : ≤ 5.25 (V).
Short circuit current : ≤ 0.6 (mA).
Short circuit detection resistance (R_{ON}) : ≤ 500 (ohm).
Open circuit detection resistance (R_{OFF}) : ≥ 100 (kilo-ohm).

NOTE

1. The last command has priority.
2. The wire connection shall be separate from the power cable line.

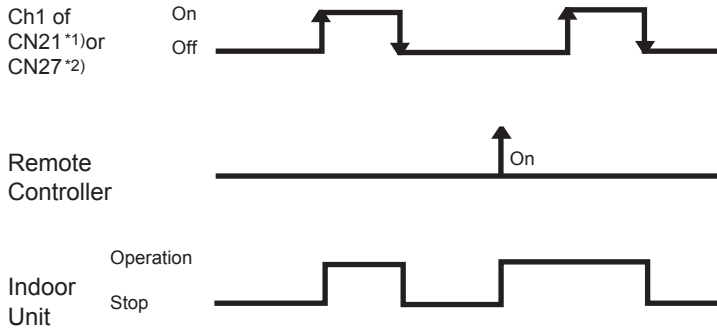

③ In the case of "pulse" input

CONNECTOR	INPUT SIGNAL	COMMAND
CN21 ^{*1)} (RED) or CN27 ^{*2)} (RED)	Ch1	OFF → ON
	Ch2	OFF → ON

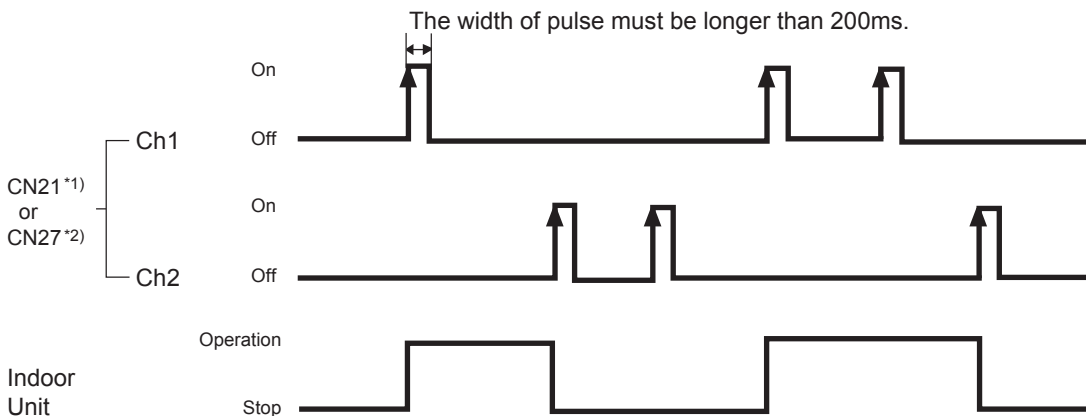

(2) Output

CONNECTOR	OUTPUT ※3)	STATUS
CN22 (WHITE)	$\geq 10\text{ V}; (\leq 15\text{ mA})$	Operation
	$\leq 2\text{ V}; (\doteq 0\text{ mA})$	Stop
CN23 (WHITE)	$\geq 10\text{ V}; (\leq 15\text{ mA})$	Error
	$\leq 2\text{ V}; (\doteq 0\text{ mA})$	Normal
CN24 (WHITE)	$\geq 10\text{ V}; (\leq 15\text{ mA})$	Fan run
	$\leq 2\text{ V}; (\doteq 0\text{ mA})$	Fan stop

※3) Output of open collector circuit.

① Operation display

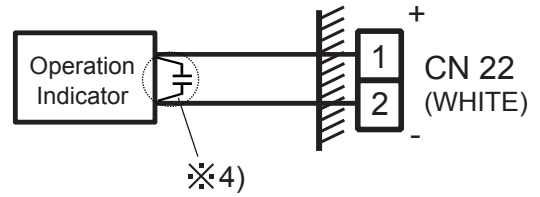
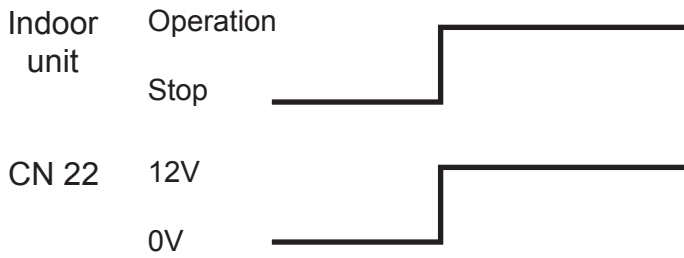

② Error display

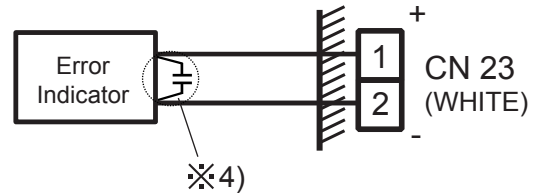
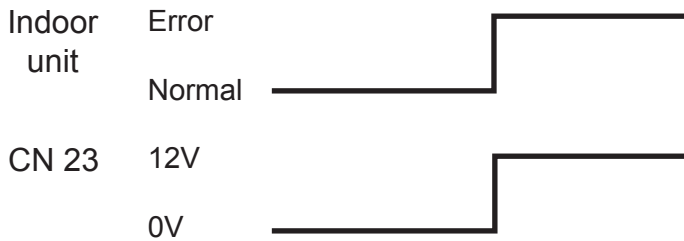

③ Inter locking output with indoor unit fan

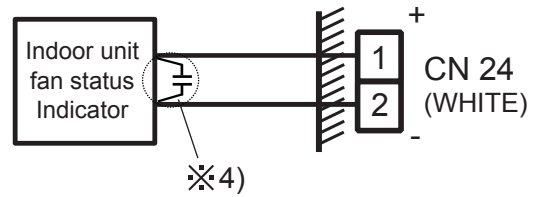
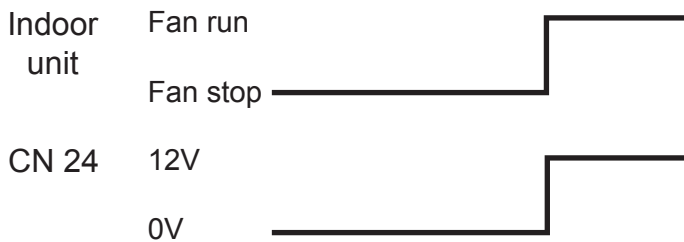

EX) Used for inter lock energize for exhaust fan.

※4) If the indicator malfunctions, please insert a ceramic capacitor ($0.1\ \mu\text{F} \pm 20\%$, $\geq 25\text{V}$) near the input port of the equipment.

(3) Parts

Following cord (service parts) is required. Please use the parts number shown below to order the cord from your sales representative.

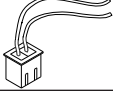
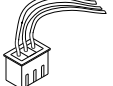
Usage	Name and shapes	Q'ty	Parts No.
For output port	EXTERNAL INPUT WIRE 	1	9368778002
For control input port	EXTERNAL INPUT WIRE 	1	9368779009

5-5-2. INDOOR UNIT(COMPACT WALL MOUNTED)

(1) Control input (Operation/Stop)

Indoor unit can be operated or stopped by using the connector CN10(RED) on indoor unit PCB.

CONNECTOR	INPUT SIGNAL	COMMAND
CN10 (RED)	OFF → ON	Operation
	ON → OFF	Stop

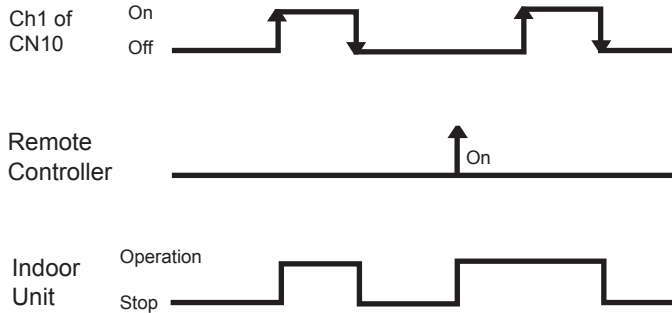
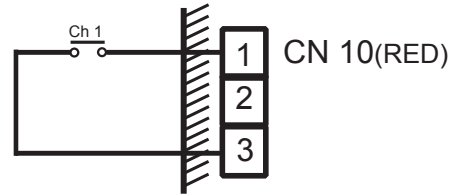

Open circuit voltage : ≤ 5.25 (V).
 Short circuit current : ≤ 0.6 (mA).
 Short circuit detection resistance (R_{ON}) : ≤ 500 (ohm).
 Open circuit detection resistance (R_{OFF}) : ≥ 100 (kilo-ohm).

NOTE

1. The last command has priority.
2. The wire connection shall be separate from the power cable line.

(2) Output

CONNECTOR	OUTPUT ^{※5)}	STATUS
CN11 (WHITE)	≥ 10 V; (≤ 15 mA)	Operation
	≤ 2 V; (≈ 0 mA)	Stop

※5) Output of open collector circuit.

Operation display

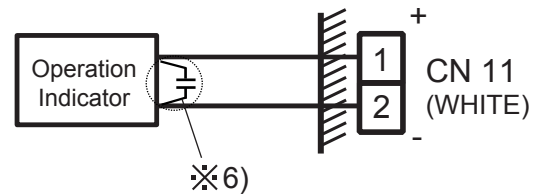
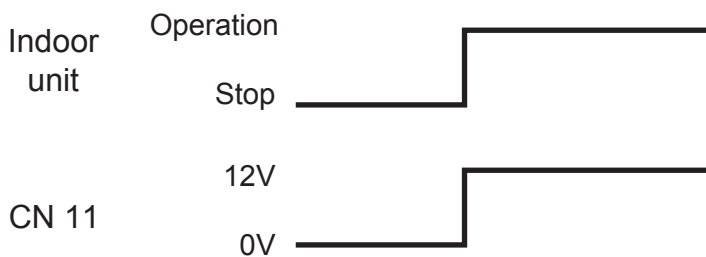

※6) If the indicator malfunctions, please insert a ceramic capacitor ($0.1 \mu\text{F} \pm 20\%$, $\geq 25\text{V}$) near the input port of the equipment.

(3) Parts

Following cord (service parts) is required. Please use the parts number shown below to order the cord from your sales representative.

Usage	Name and shapes	Q'ty	Parts No.
For output port	EXTERNAL INPUT WIRE	1	9368778002
For control input port	EXTERNAL INPUT WIRE	1	9368779009

5-5-3. OUTDOOR UNIT

(1) Input

Heat and Cool switch (Heat pump type only)

"Cooling priority" or "Heating priority" can be selected by this input.

CONNECTOR	INPUT SIGNAL	STATUS	REMARKS
CN50 (YELLOW)	OFF	Remote Controller priority	
	ON	External input priority	
CN52 (GREEN)	OFF	Cooling priority	CN50 need to be "ON".
	ON	Heating priority	

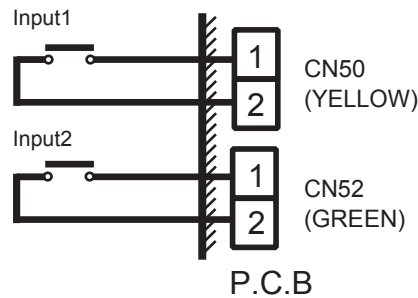
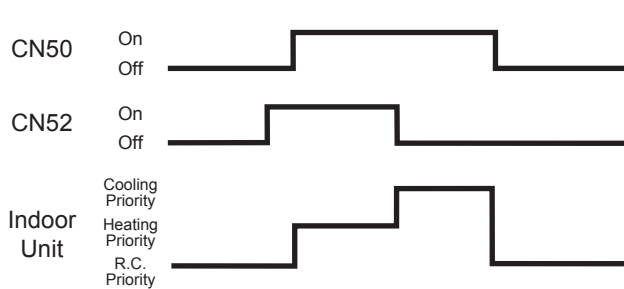

Open circuit voltage : ≤ 5.25 (V).
 Short circuit current : ≤ 0.6 (mA).
 Short circuit detection resistance (R_{ON}) : ≤ 500 (ohm).
 Open circuit detection resistance (R_{OFF}) : ≥ 100 (kilo-ohm)

(2) Output

① Operation display

This output indicates the outdoor unit's "Operation" status.

② Error display

This output indicates the outdoor unit and connected indoor unit's "Normal" or "Error" status.

CONNECTOR	OUTPUT ^{※8)}	STATUS
CN48 (BLUE)	≥ 10 V; (≤ 100 mA)	Operation
	≤ 2 V; (≈ 0 mA)	Stop
CN49 (BLACK)	≥ 10 V; (≤ 100 mA)	Error
	≤ 2 V; (≈ 0 mA)	Normal

※8) Output of open collector circuit.

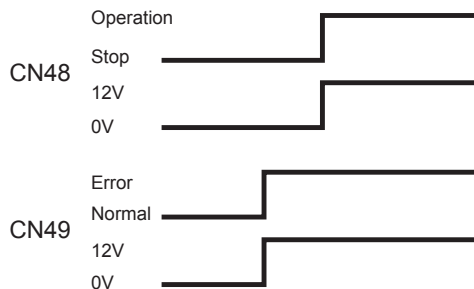
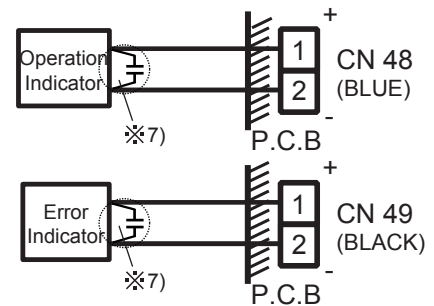

※7) If the indicator malfunctions, please insert a ceramic capacitor ($0.1\mu\text{F} \pm 20\%$, $\geq 25\text{V}$) near the input port of the equipment.

③ Base heater output

Turn ON when the ambient temperature is low in heating mode.(3°C or less)

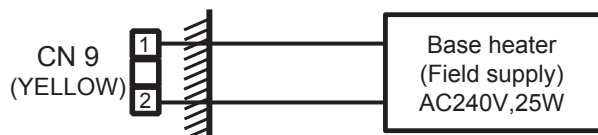

(3) Parts

Following cord (service parts) is required. Please use the parts number shown below to order the cord from your sales representative.

Usage	Name and shapes	Q'ty	Parts No.
For base heater port	BASE HEATER WIRE	1	9374796014
For input & output port	EXTERNAL INPUT WIRE	1	9368777005

5-5-4. GROUP REMOTE CONTROLLER CONVERTER

■ Control input

① Input select

7 Segment	Input select
00	External input function Invalidity
01	Edge
02	Pulse

※It shows next page about how to setting operation.

② In the case of "Edge" input.

CONNECTOR		INPUT SIGNAL	COMMAND
CN451	CN1	OFF → ON	All ON
		ON → OFF	All OFF

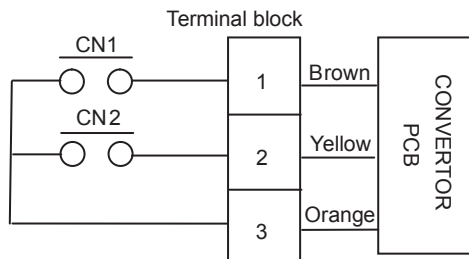

Open circuit voltage : 12 (V) ± 5%.
 Short circuit current : ≤ 2 (mA).
 Short circuit detection resistance (R_{ON}) : ≤ 500 (ohm).
 Open circuit detection resistance (R_{OFF}) : ≥ 100 (kilo-ohm).

<Operation>

When it input GND short signal of 200ms or more to terminal 1, it transfer this operation signal to all indoor unit on the this network. When it input GND open signal of 200ms or more to terminal 1, it transfer this stop signal to all indoor unit on the this network.

However, it limits it when there is a change in the state.

(The operating signal has been output. → GND short signal is 200ms or more

The stopping signal has been output. → GND open signal is 200ms or more)

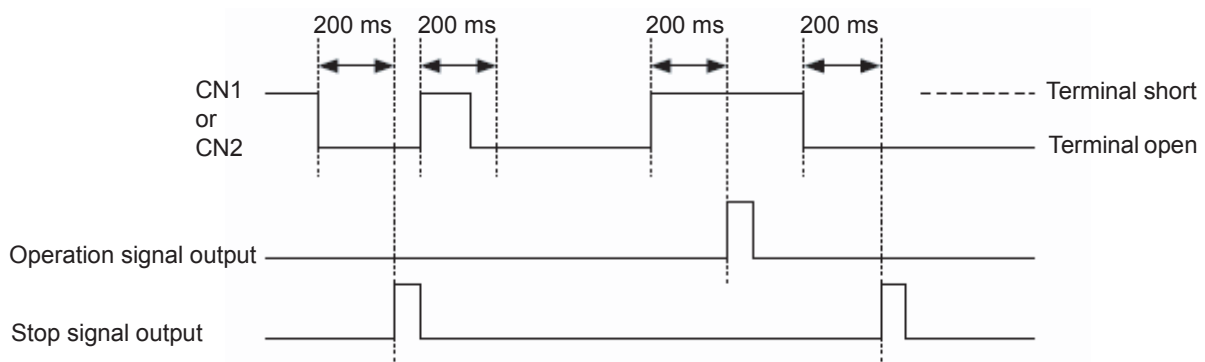

③ In the case of "pulse" input

CONNECTOR		INPUT SIGNAL	COMMAND
CN451	CN1	OFF → ON	All ON
	CN2	OFF → ON	All OFF

<Operation>

When it input GND short signal of 200ms or more to terminal 1, it transfer this operation signal to all indoor unit on the this network.

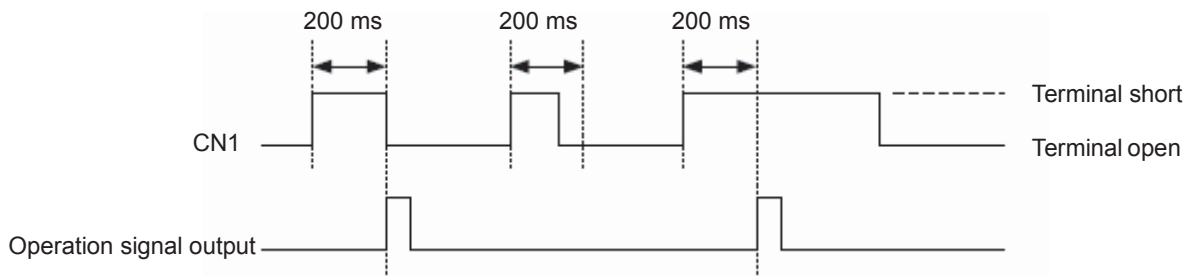

When it input GND short signal of 200ms or more to terminal 2, it transfer this operation signal to all indoor unit on the this network.

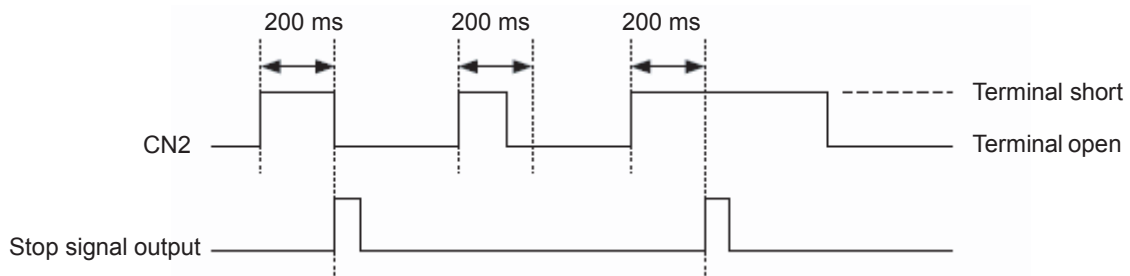

■ GROUP REMOTE CONTROLLER CONVERTER how to setting operation

Setting of external input function selection.

- It is necessary to set a initial parameter setting on the group remote convertor Printed circuit board.
- An external input setting is invalid on factory setting. It set up to use the button on the main Printed circuit board.

① At first, connect indoor unit, Group remote convertor and Group remote controller.
And next, the setting begins from the state to supply the power supply.
Red LED lights while this conition.

② Push the “MODE” button on the group remote convertor main Printed circuit board.

- It displays “ - Pr - ” on the 7 segment(monitor lamps).(following the fig)

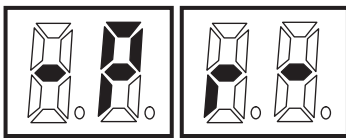

- The display change as following the fig.(2 seconds)

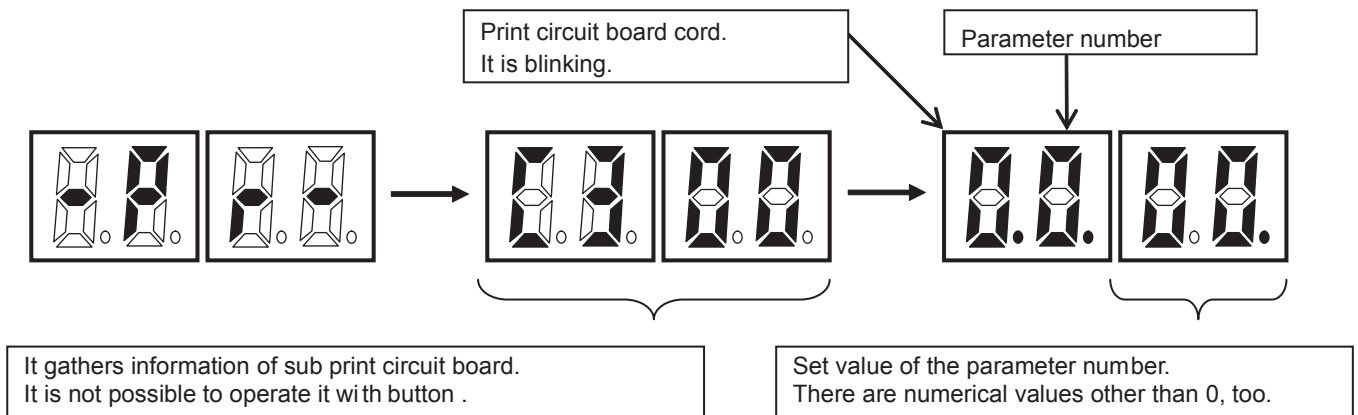

③ Push the [UP] or [Down] button.

- Select to the code“2” as follows by using [UP] or [Down] button .
- The blinking digit can be increased or decreased by the [UP] or [Down] button operating.

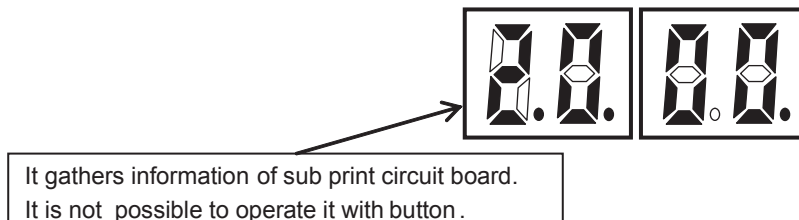

④ Push the “SELECT” key.

- The blinking part turn the right side (parameter number).

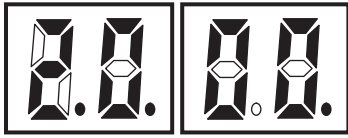

Set value of the parameter number.
It changes into blinking.

⑤ Select the input method of an external input with the key of “UP” or “DOWN” setting.

Set value	External input function
00	External input function invalidity
01	Edge input
02	Pulse input

⑥ Push “SET” button.

When you push the “SET” button, all digit of 7 segment(monitor lamps) a blink once.

⑦ Push “MODE” button.

7 segment(monitor lamps) blinks only when there is a setting change. Afterward, it returns to the ordinary mode.

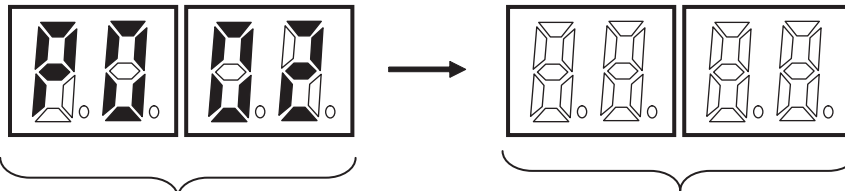

When there is a change in a set value ,
7 segment(monitor lamps) are blinking.

It returns to the ordinary mode.
Turning off or the error code is displayed.

Blinking is the Red LED.

5-6. INSTALLATION WORK

5-6-1. INSTALLATION THE OUTDOOR UNIT

■ SELECTING THE MOUNTING POSITION

⚠ WARNING

Install the unit where it will not be tilted by more than 5°.

When installing the outdoor unit it may be exposed to strong wind, fasten it securely.

- * Set the unit on a strong stand, such as one made of concrete blocks to minimize shock and vibration.
- * Do not set the unit directly on the ground because it will cause trouble.
- * Do not install the unit where a strong wind blows or where it is very dusty.
- * Install the unit so that it will not fall down or harm people.
- * If outdoor unit is not installed to specifications, capacity may drop because of a short-circuit. As a result, a high pressure error may occur.
- * Since specified values are minimum permissible measurements, install unit after duly considering the measurements required for installation location, piping work and maintenance.

● FOR INDIVIDUALLY

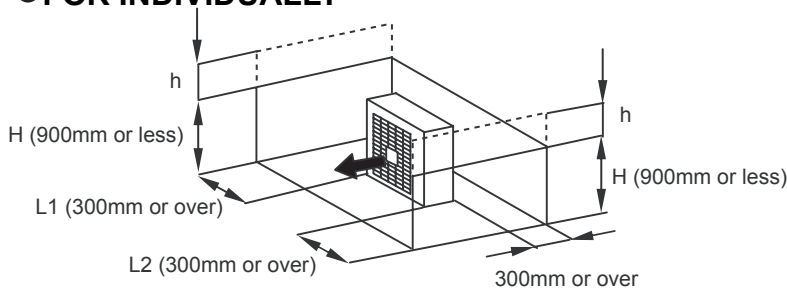

The height (H) of the side wall should be less than 900mm.

If the height (H) of the side walls exceeds 900mm by h mm, and h mm to the space widths for L1 and L2.

$$H \leq 900 : L1 \geq 300, L2 \geq 300$$

$$H > 900 : L1 > 300 + h, L2 > 300 + h$$

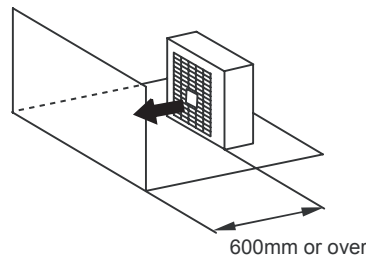
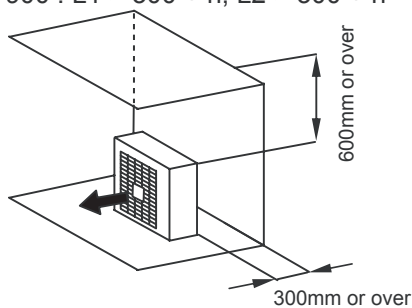

● FOR CONTINUOUS

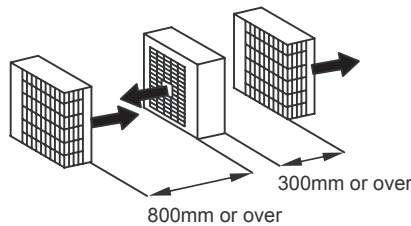
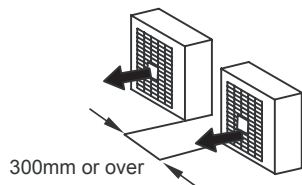

← : Air discharge

■ ANCHOR BOLT POSITIONS

Install the anchor bolts to bear enough strength.

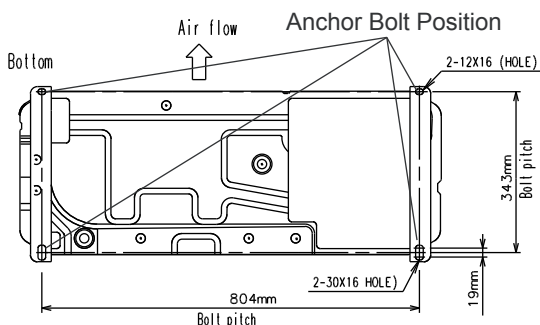

5-6-2. INSTALLATION SPACE

■ COMPACT DUCT TYPE

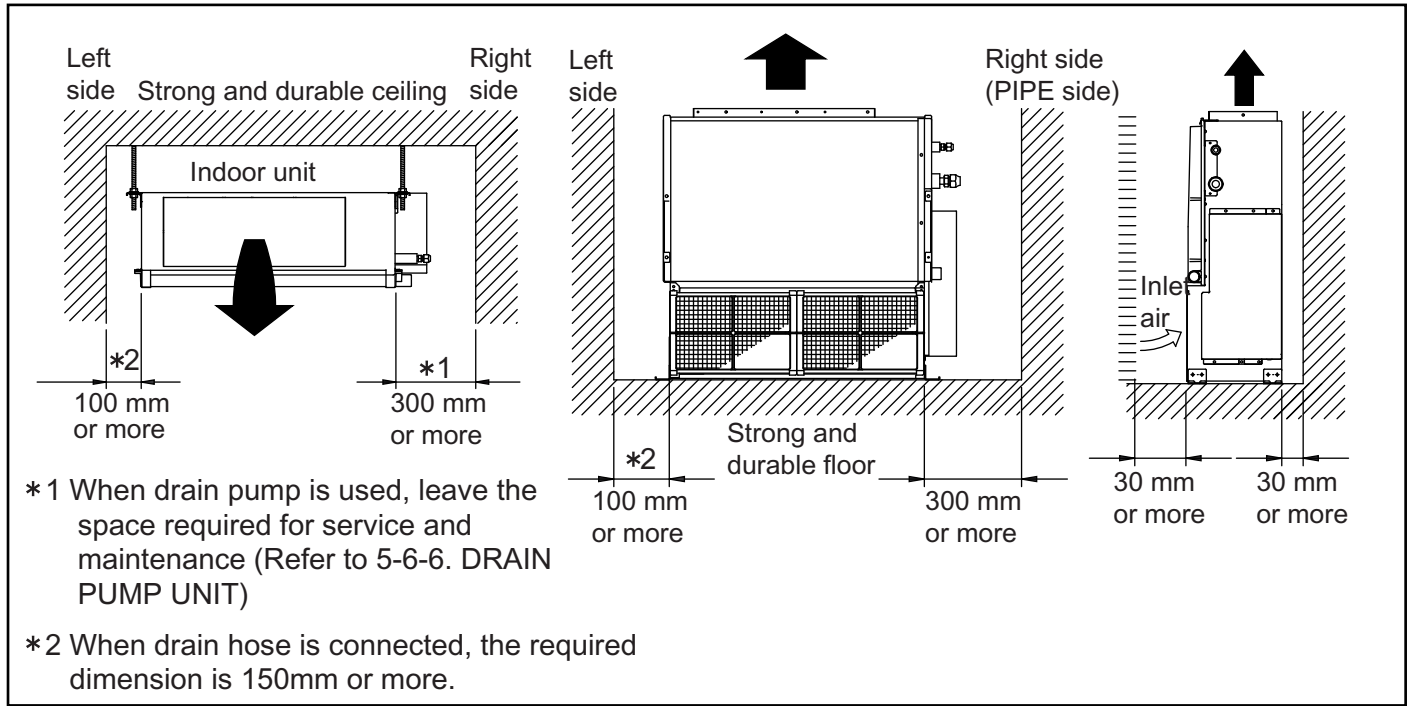

■ LOW STATIC PRESSURE DUCT TYPE / DUCT TYPE

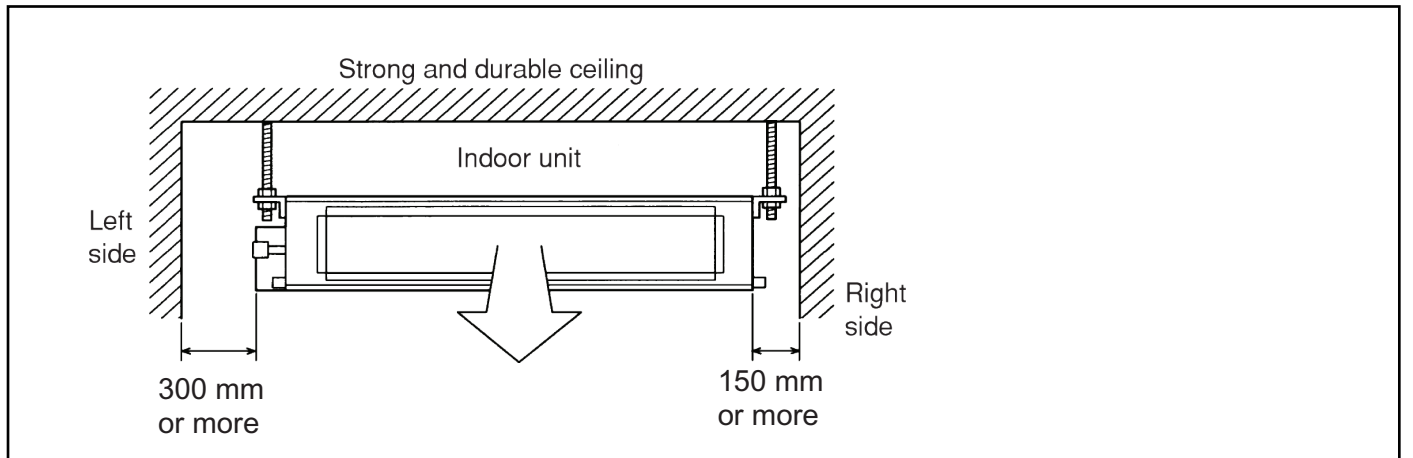

■ COMPACT CASSETTE TYPE

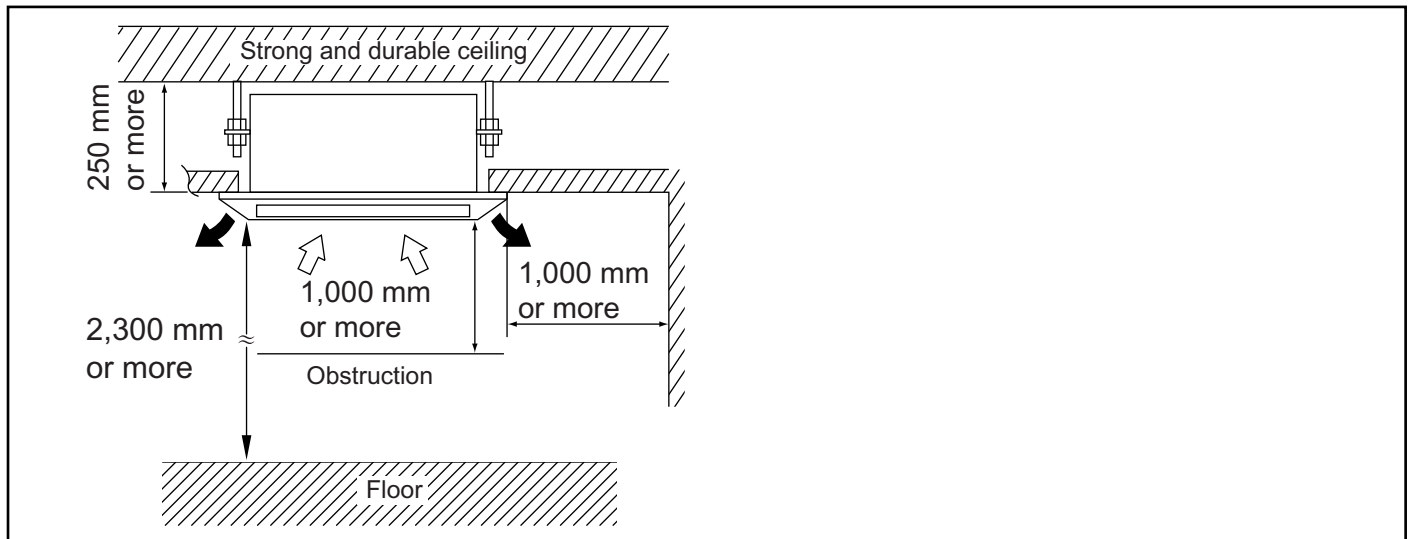

■ CASSETTE TYPE

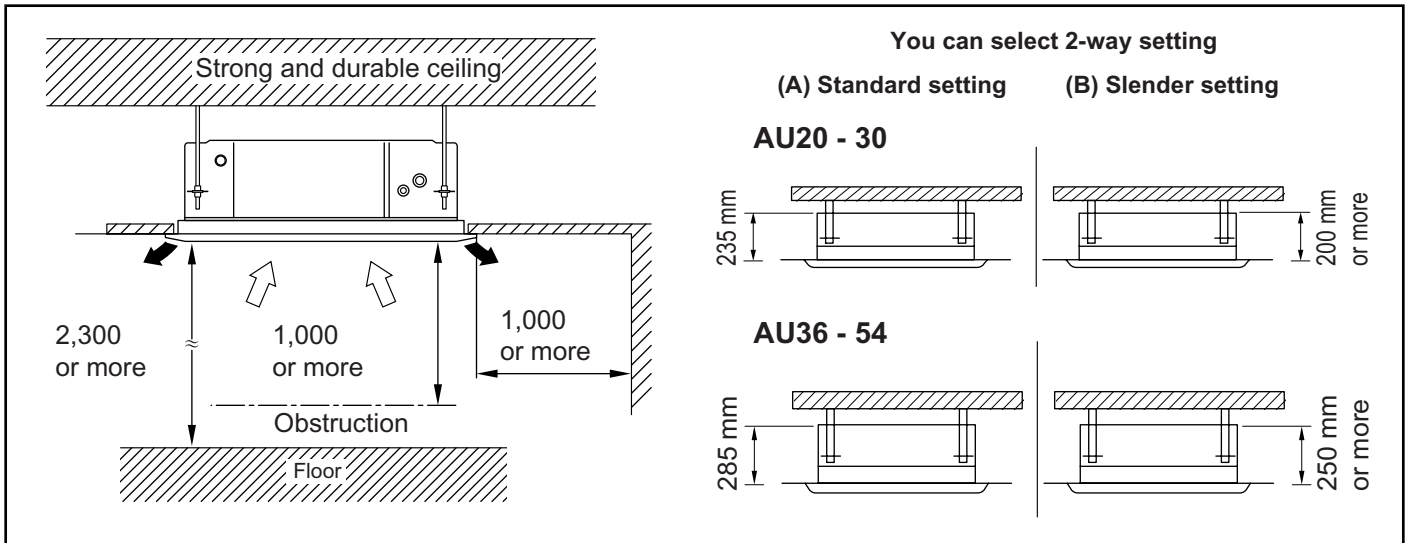

■ COMPACT WALL MOUNTED TYPE

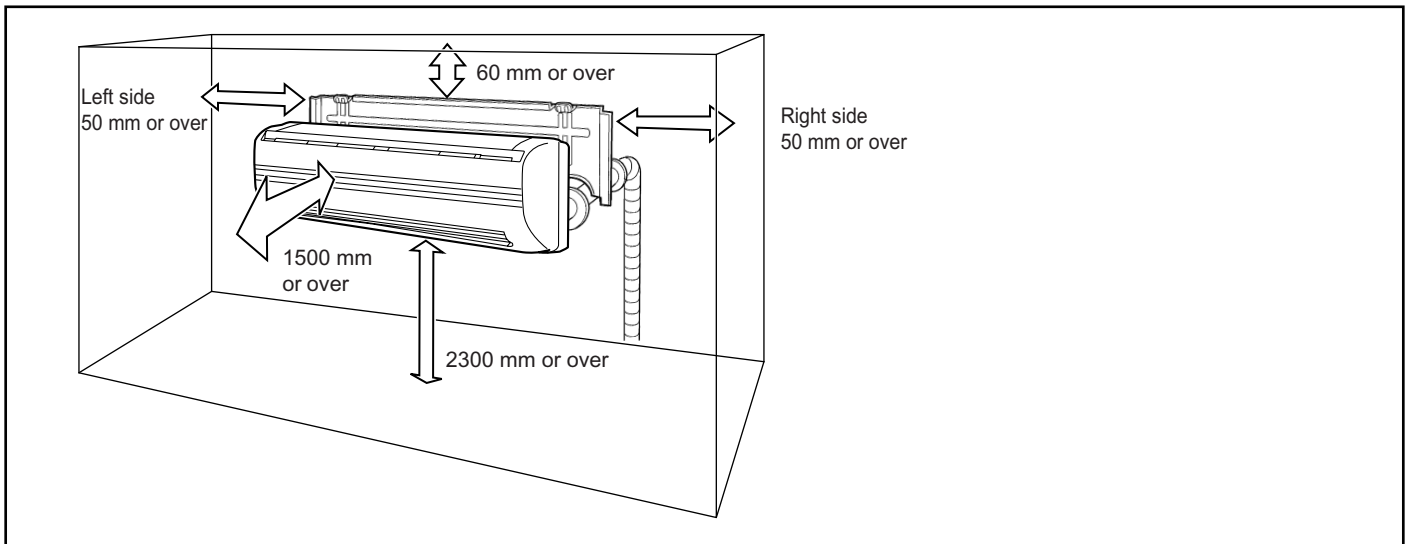

■ WALL MOUNTED TYPE

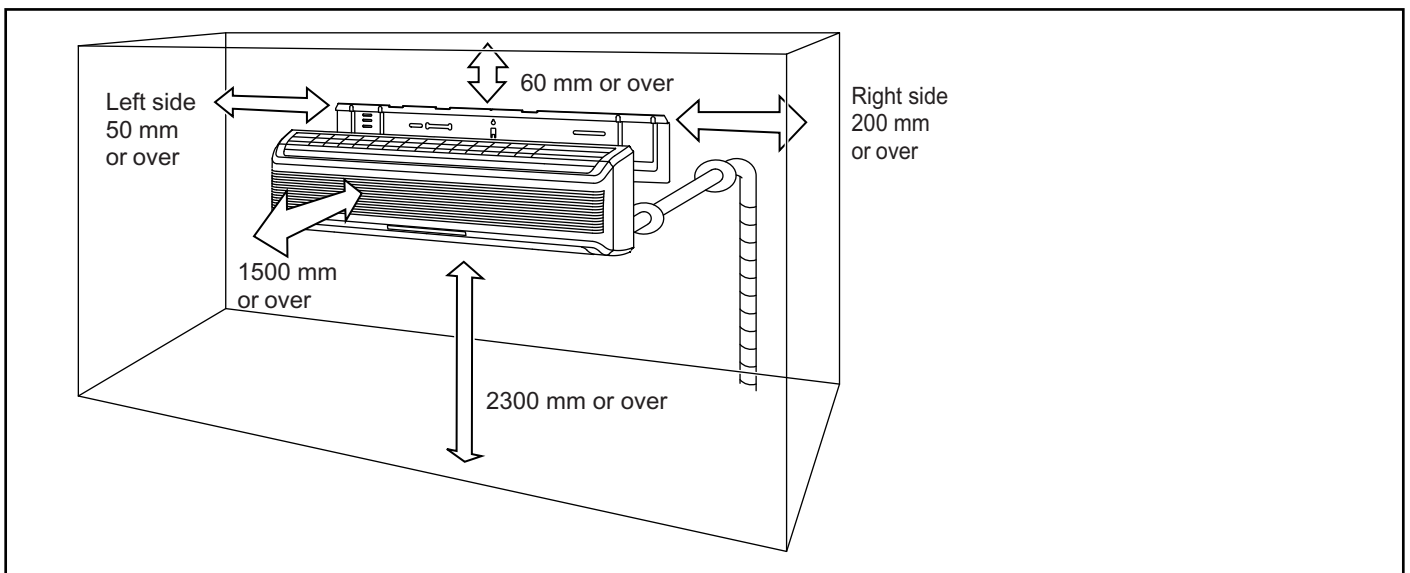

■ CAUTION

WARNING

Install at a place that can withstand the weight of the indoor and outdoor units and install positively so that the units will not topple or fall.

CAUTION

Do not install where there is the danger of combustible gas leakage.

Do not install the unit near a source of heat, steam, or flammable gas.

If children under 10 years old may approach the unit, take preventive measures so that they cannot reach the unit.

Decide the mounting position with the customer as follows:

Install the indoor unit on a strong wall ,floor,ceiling which is not subject to vibration.

The inlet and outlet ports should not be obstructed. The air should be able to blow all over the room.

Do not install the unit where it will be exposed to direct sunlight.

Install the unit where the connection pipe can be easily installed.

Install the unit where the drain pipe can be easily installed.

Take servicing, etc. into consideration and leave the spaces. Also install the unit where the filter can be removed.

Install the indoor unit where vibrations and noise are not amplified.

When installing the unit on the floor, make sure that there is plenty of space a around the inlet port.

5-6-3. PIPING CONNECTION

■ CAUTION

- * Use the designated size (diameter & thickness) of refrigerant pipes.
- * Those pipes purchased locally may contain dust inside. Please blow out the dust by dried inert gas when using.
- * Be careful to avoid the dust or water falling into the pipe when performing piping process and piping installation.
- * When processing the pipe, make the number of bending portion as few as possible, and the bending radius as large as possible.
- * To process the branch, do not use T-shaped pipe, which causes a uneven refrigerant flow. Use the optionally available standard branch kit.

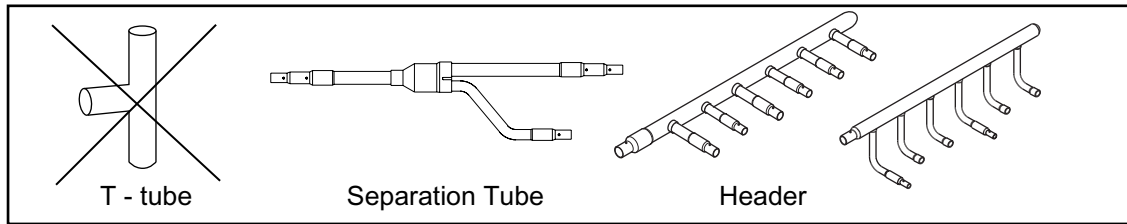

- * Install branch kit in the direction specified in installation manual.

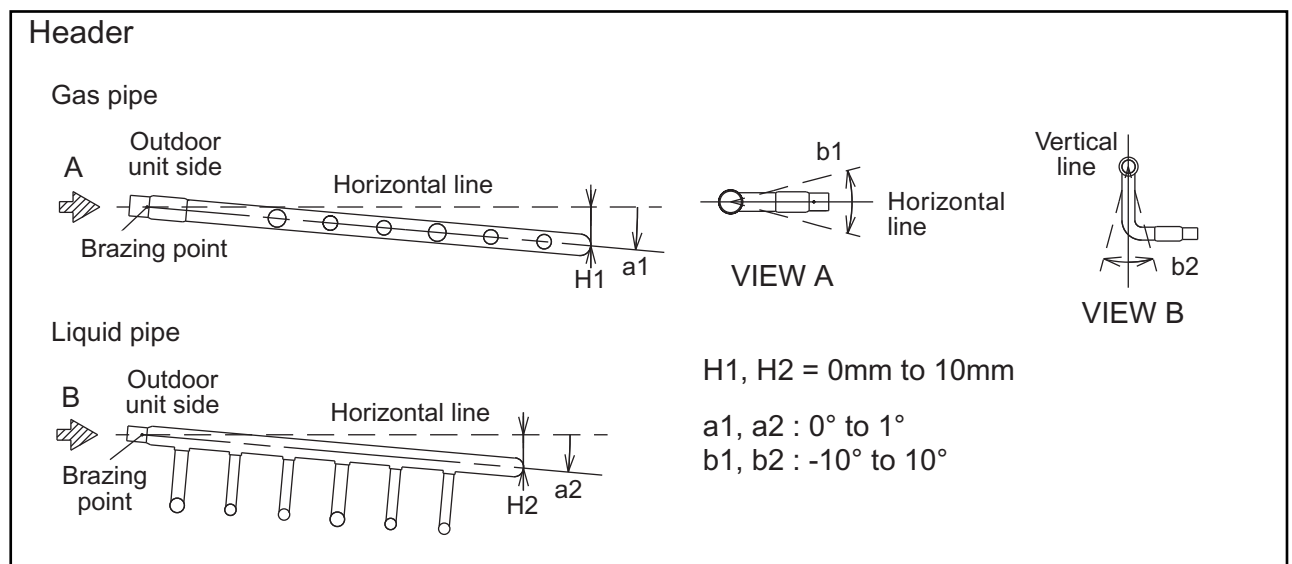
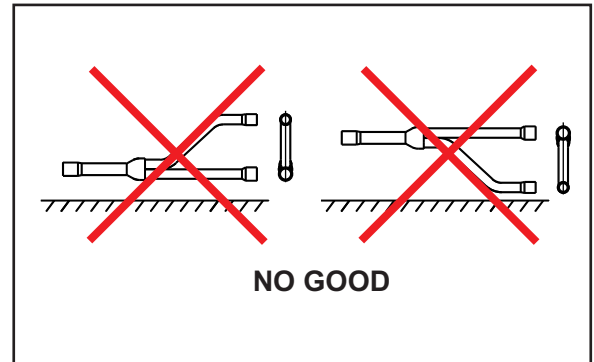
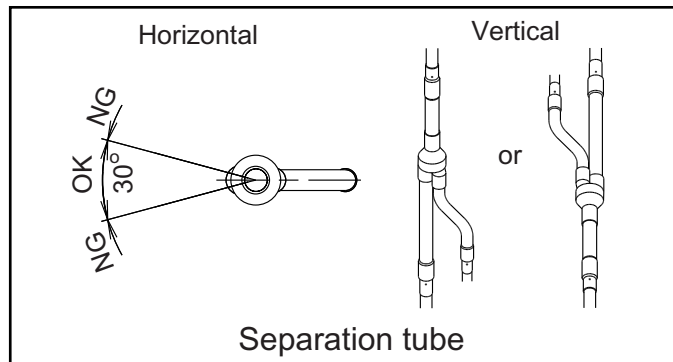

- * If the diameter of the required pipe is different from the branch unit, either cut it out or use reducer.

■ CAUTION

- * Keep the permissible length of every piping limitation to prevent a defect or cooling failure.
- * When replacing the unit, never use piping which has been used for previous installations. Only use the new piping.
- * Welding
While welding the pipe, be sure to blow dry nitrogen gas through the pipes. If not used, it will be caused to damage for compressor and clog the strainer and electronic expansion valve.

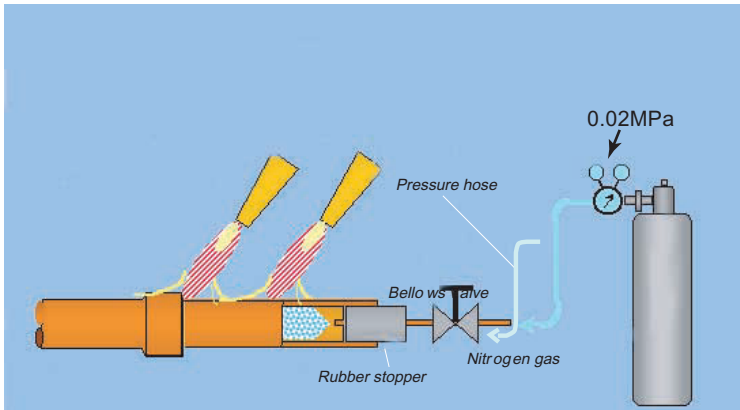

Example) Inside state of welding pipe section

Nitrogen Gas used



Nitrogen Gas used but not sufficient
(Oxygen gas still inside the pipe)



Nitrogen Gas does not used



- * The pipes vibrate, expand, and contract during operation, so if loads are concentrated in one area, it could cause cracks in the pipes. Provide the pipes with supports every 2 to 3m.
- * Make sure to insulate the refrigeration pipes separately with ample thickness of heat-resistant polyethylene foam etc. For the connecting portion, apply the enough insulation to avoid any gap.

■ FLARE PROCESSING

- (1) Cut the connection pipe with pipe cutter so that the pipe is not deformed.
- (2) Holding the pipe downwards so that cutting cannot enter the pipe and remove the burrs.
- (3) Remove the flare nut from the indoor unit pipe and assemble as shown in Table 1 and insert the flare nut onto the pipe, and flare the pipe with a flare tool.
- (4) Use either a flare tool for R410A or conventional flare tool. Flare processing dimensions differ according to the type of flare tool. Be careful. When using a conventional flare tool, be sure to secure "Dimension A" by using a gage for size adjustment.
- (5) Check if the flared part is spread uniformly and that there are no crack. Finally, check the "Dimension D" to confirm that the flared part was produced in correct size.

Outer diameter of pipe d (mm)	Flare nut width $L1$ (mm)	Dimension A (mm)		Dimension D (mm) (tolerance +0.0 mm -0.4 mm)	Tightening torque (N·m)
		Flare tool for R410A (Clutch type)	Flare tool for R22 (Clutch type)		
6.35	17	0 to 0.5	1.0 to 1.5	9.1	16.0 to 18.0
9.52	22	0 to 0.5	1.0 to 1.5	13.2	30.0 to 42.0
12.70	26	0 to 0.5	1.0 to 1.5	16.6	49.0 to 61.0
15.88	29	0 to 0.5	1.0 to 1.5	19.7	63.0 to 75.0
19.05	36	0 to 0.5	1.0 to 1.5	24.0	90.0 to 110.0

Flare nut width

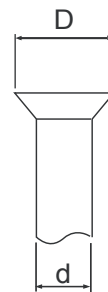
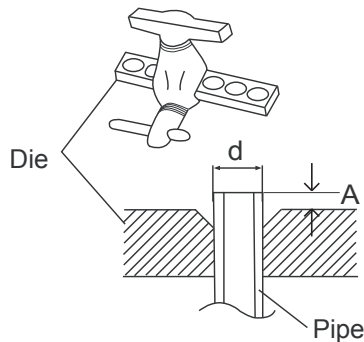
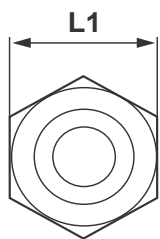

■ Separation tube installation

Outdoor unit or
Refrigerant branch kit

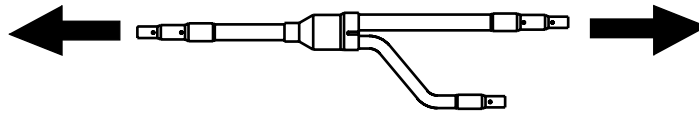

Indoor unit or
Refrigerant branch kit

Install the separation tube so that it branches either horizontally or vertically.

Horizontal

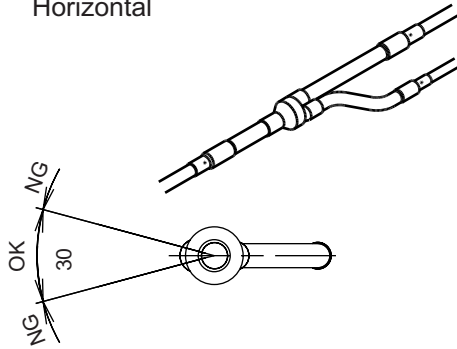

Vertical

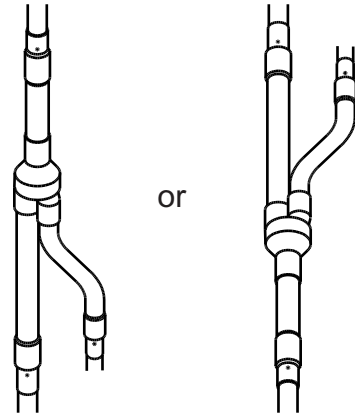

Use the pipe cutter to cut at the location which matches the piping size when the piping size is different.

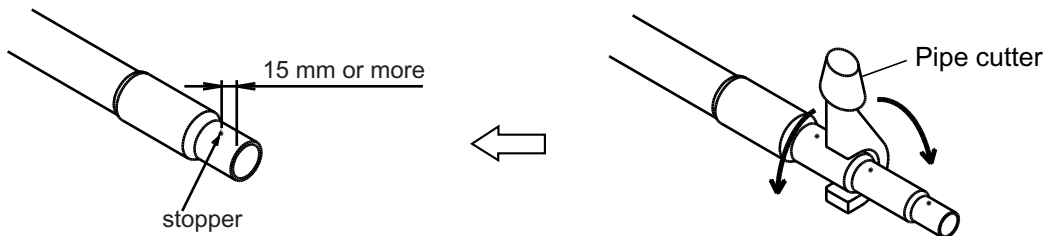

INSTALLATION

INSTALLATION

● Distance between separation tubes

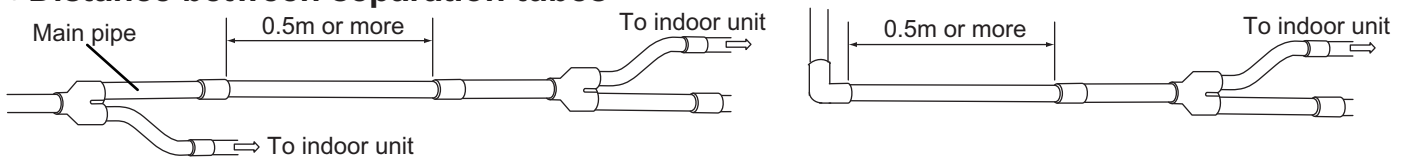

Caution

Leave the distance 0.5m or more for straight part to separation tube.
(To prevent the outdoor unit malfunction and generation of refrigerant noise)

● Heat insulation installation (For UTR-BP054X)

After brazing the pipes, use the supplied insulation to insulate them.

1) Remove the protective sheet from the double-stick that is affixed to the heat insulation.

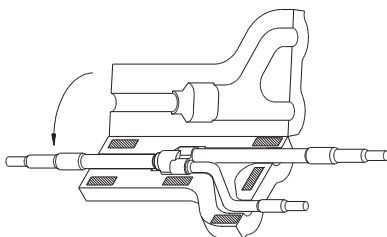

- 2) Be sure to install the tape (accessory) in each heat insulation to the 4 positions as shown in the following figure.

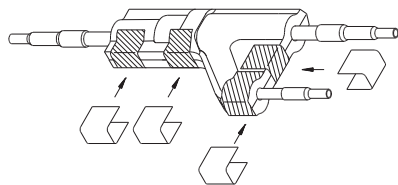

- 3) Use tape (locally procured) to seal the seam so that there will be no gap at the junction between the aforementioned heat insulation and the heat insulation on the local piping.

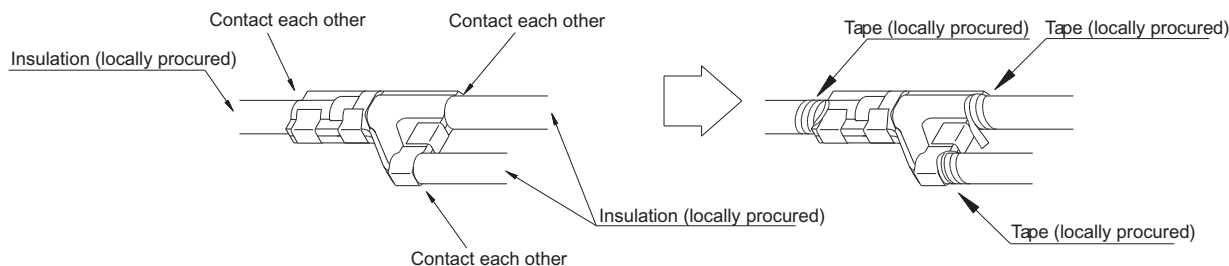

CAUTION

As with the gas pipes, fully insulate the liquid pipes. Unless they are thermally insulated, water condensation can cause accidents or reduction in performance.

After installing the heat insulation, if you worry about possible condensation, please cover the heat insulation onto the gas pipe from top at field installation.

[Add the standard of heat insulating material]

When using, the environment temperature should be higher than 35°C and humidity over 85%.

When using, the environment temperature should be higher than 25°C and humidity over 90%.

Installation example

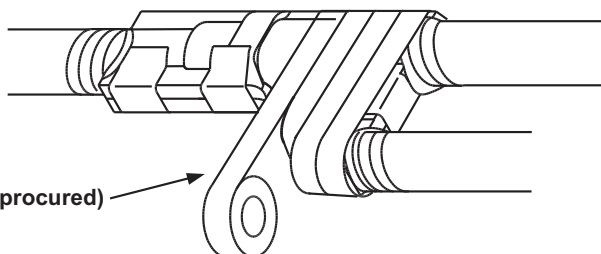

● Heat insulation installation (For UTR-BP54U)

After brazing the pipes, use the supplied insulation to insulate them.

- Remove the protective sheets from the adhesive strips attached to the supplied heat insulation.
- Fasten the heat insulation to the separating tube using binders in two locations.
- If the separation tube is not covered, install the heat insulation over the entire surface of the separating tube.

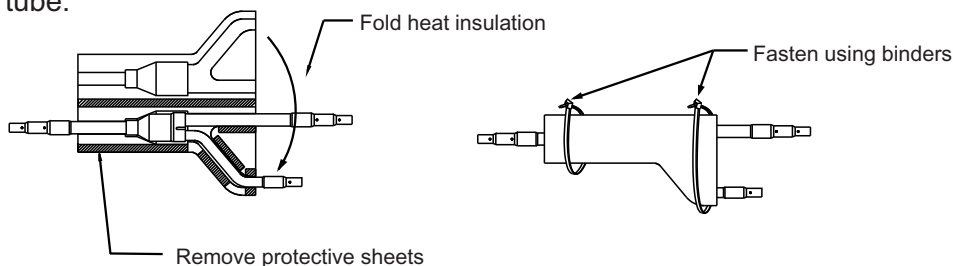

CAUTION

Make sure that the pipe is covered completely by the insulation, not exposing to air. Inadequate heat insulation may cause condensation.

If the temperature and the relative humidity around the cooling pipes are expected to exceed 30°C (86°F) and 80%RH, increase the thickness of the heat insulation for the pipes to at least 20mm (13/16"). Otherwise, condensation might form on the surface of the insulation.

Header installation

• Caution

Separation after header is not allowed.

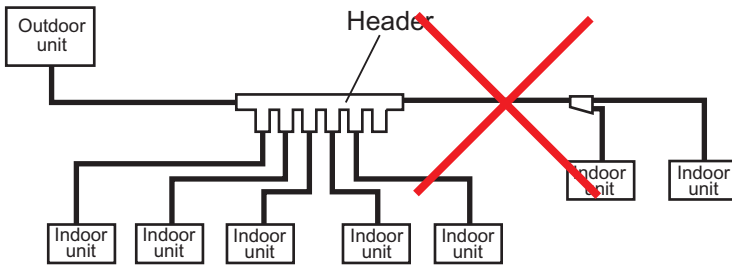
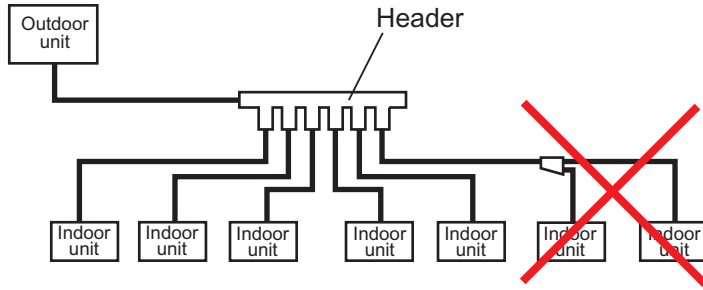

• Piping connection

- (1) When connecting the connection pipes from the indoor units, connect them to the header branch pipes in the order 1, 2, 3, etc.

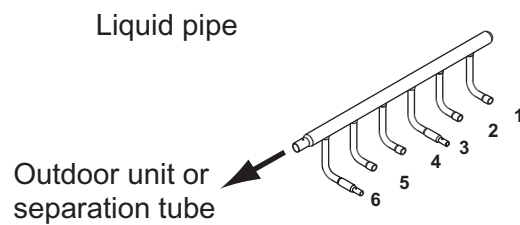
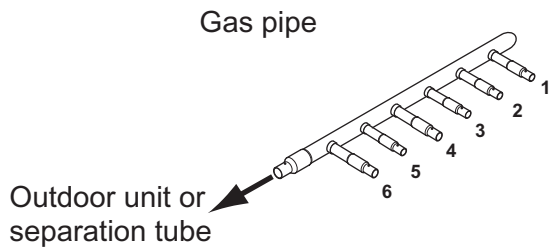

- (2) Use a pipe cutter to cut at the location that matches the piping size.
Be sure to cut the piping off at least 15 mm from the piping stopper
If the piping is cut too short, leaks can occur. After cutting the piping off, be sure to deburr it.
Make sure that dirt or water does not enter the piping when connecting the piping.

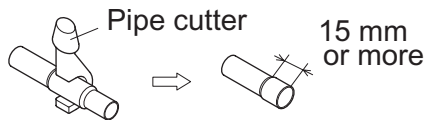

- (3) Attach a plugging pipe provided if there is no piping connected at the headers.

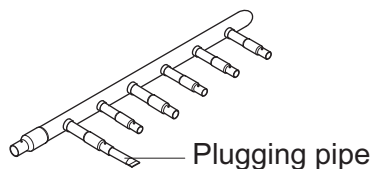

● Installation

Install the header so that it branches horizontally.

Use a level to make sure that the header is positioned as shown in following figure, and then, secure it in place.

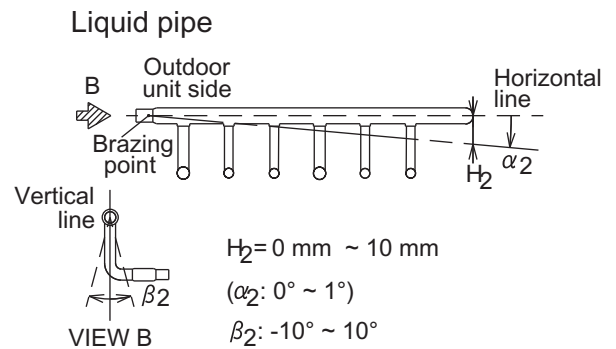
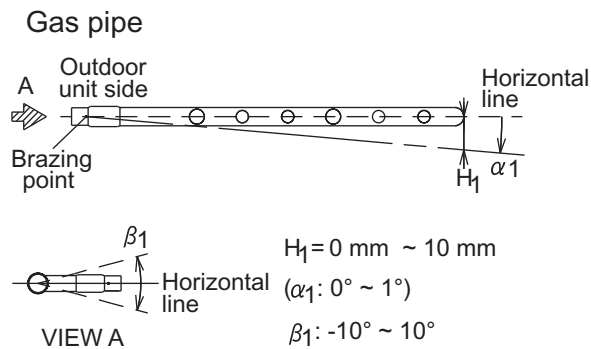

● Heat insulation installation

After brazing the piping, attach heat insulation.

Remove the protective paper for the tape on the heat insulation for the header and attach it.

Tighten by using binders in five locations.

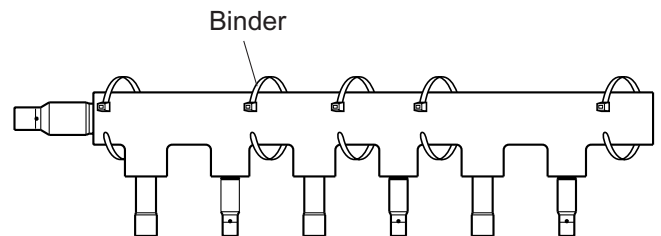
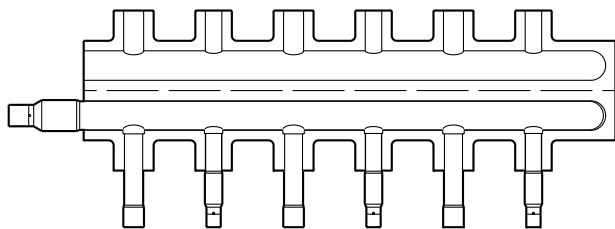

Cover the plugging pipe with heat insulation and seal with tape.

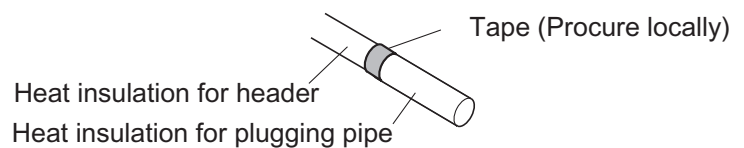
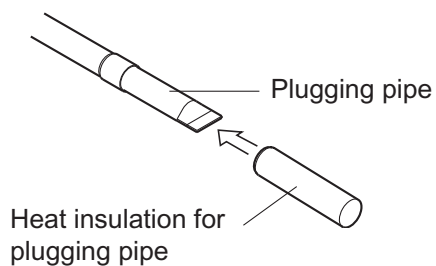

EV KIT INSTALLATION

EV kit selection

Model name of EV kit	Dimension (H x W x D) (mm)	Applicable to indoor unit with following model code
UTR - EV2A*L	83 x 288 x 45	<30
UTR - EV3*L	97 x 290 x 50	≥30

⚠ CAUTION (for UTR - EV2A*L)

Be sure to connect the EV KIT as shown in the following figure. Otherwise, the EV KIT and indoor unit could be damaged.

● Horizontal direction

Install the EV KIT so that the arrow on the label is within the range shown in the figure.

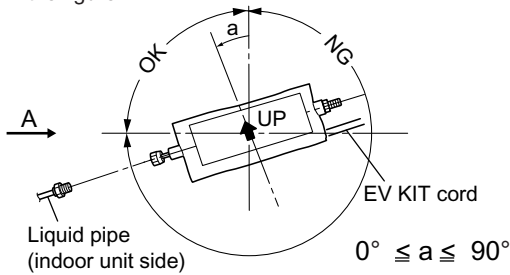

● Rotation direction

Install the EV KIT so that the arrow on the label is facing up.

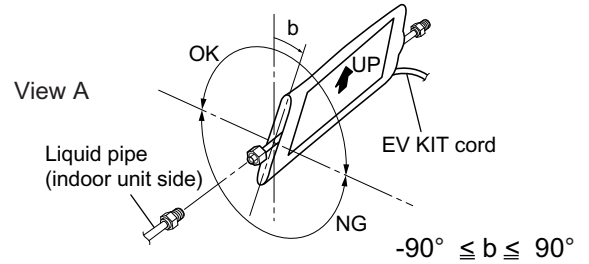

⚠ CAUTION (for UTR - EV3*L)

Be sure to connect the EV KIT as shown in the following figure. Otherwise, the EV KIT and indoor unit could be damaged.

● Horizontal direction

Install the EV KIT so that the arrow on the label is within the range shown in the figure.

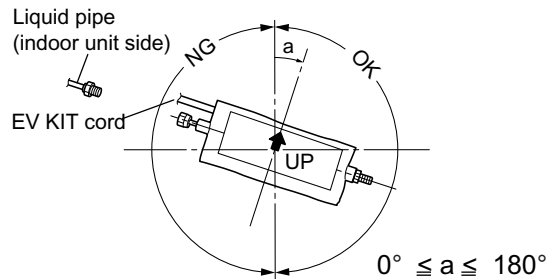

EV kit installation

(1) Connect the flare nut side of the EV KIT to the liquid pipe of the indoor unit.

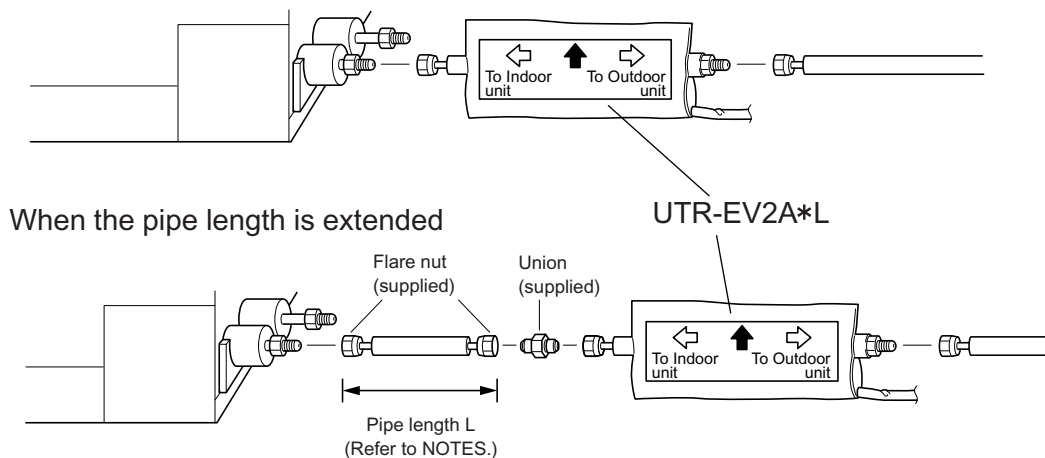

i NOTES (for UTR - EV2A*L)

[For wall mounted type indoor units]

- The EV KIT cannot be installed to the rear of compact wall mounted type indoor units. Install the EV KIT to the piping from the left or right side of the indoor unit as shown in the following figure.
- Refer to the table for the maximum pipe length of L, L1, L2.

	L	L1	L2
Compact wall mounted type	1.0 m	0.7 m	1.2 m
Wall mounted type	0.8 m	0.2 m	1.0 m

- Use a pipe cover with a width of 100 mm or more.

[For duct type indoor units (AR25UFAAR only)]

- Maximum pipe length of L is 0.9 m.

[For other indoor units]

- Maximum pipe length of L is 1.2 m.

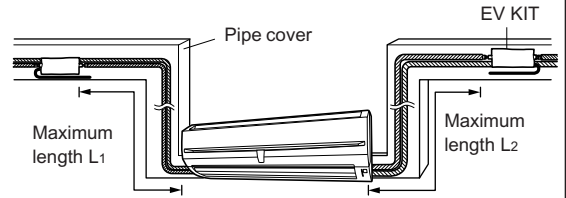

i NOTES (for UTR - EV3*L)

[For wall mounted type indoor units]

- Maximum pipe length of L is 1.1 m.
(L1=0.5 m, L2=1.3 m)
- When using a pipe cover, make sure that the width x height of the cover is 140 mm x 50 mm, or 100 mm x 100 mm or greater.

[For duct type indoor units (AR36UFAAR, AR45UFAAR)]

- Maximum pipe length of L is 1.2 m.

[For other indoor units]

- Maximum pipe length of L is 1.5 m.

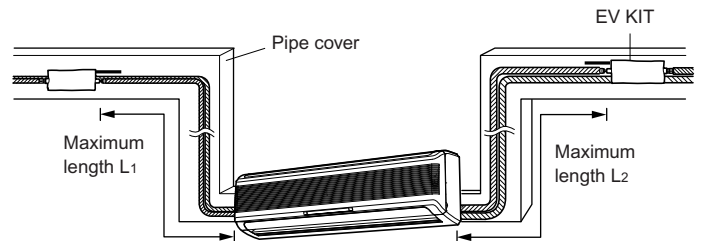

(2) Connection pipe

When the flare nut is tightened properly by your hand, hold the body side coupling with a separate spanner, then tighten with a torque wrench.

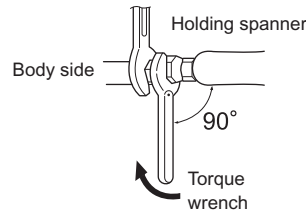

Table

Pipe	Tightening torque
φ6.35 (1/4")	14.0 to 18.0 N·m
φ9.52 (3/8")	33.0 to 42.0 N·m

(3) Connect the wire

- ① Wrap the tube (long) around the EV KIT cord from the end of the cord to the indoor unit control box so that the cord will not be exposed, and then fasten both ends of the tube with the binders (small).
(Cut the tube (long) if it is too long and will enter the indoor unit control box.)
- ② When the pipe length was extended
 - Use the supplied wire to extend the length of the EV KIT cord.
 - Wrap the tube (short) around the connection, and then fasten both ends with the binders (small) as shown in the figure to the right.
- ③ Connect the EV KIT cord to the indoor unit. (Refer to the INSTALLATION MANUAL of the indoor unit.)
- ④ Fasten the EV KIT cord to the piping, etc., with the binders (medium) to remove any slack in the cord.

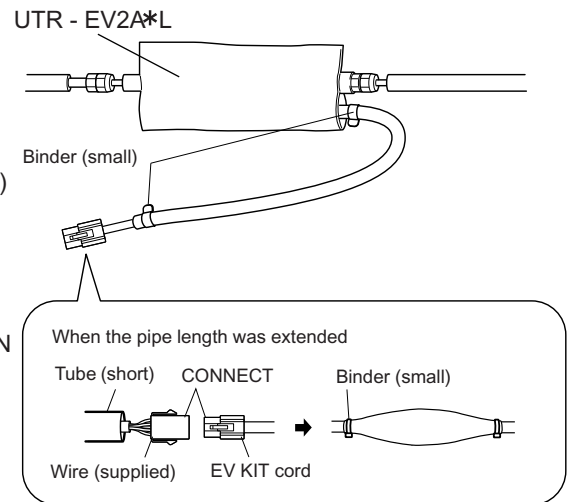

(4) Finishing

Before performing this section, perform a sealing test. (Refer to the INSTALLATION MANUAL of the outdoor unit.)

WARNING

Make sure that the pipe is covered completely by the insulation, not exposing to air. Inadequate heat insulation may cause condensation.

- ① Put all the six heat insulating seals around the EV KIT.
Fix with the binders (large).
- ② Insulate the EV KIT connecting part.

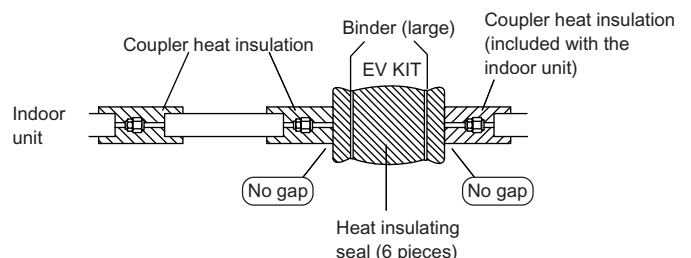

■ AIR TIGHT TEST

After the piping has been installed, perform a sealing test.

Charge the piping with nitrogen to within the sealing test pressure (4.2 MPa).

After 24 hours, check that the pressure has not fallen.

Make sure to add the pressure to both Gas pipe and Liquid pipe.

Perform the leak test on all flared and brazed parts.

Note: When the ambient temperature changes 5 deg. , the test pressure changes 0.07MPa.

■ VACUUM PROCESS

⚠ CAUTION

Do not purge the air with refrigerant but use a vacuum pump to remove air from the indoor unit and connection pipes!

- (1) Remove the cap, and connect the gauge manifold and the vacuum pump to the charging valves by the service hoses.
- (2) Vacuum the indoor units and the connecting pipes until the pressure gauge indicates -76cmHg . Be sure to vacuum from both 3-way valves.
- (3) When -76cmHg is reached, operate the vacuum pump for at least 1 hour.
- (4) If necessary, add the refrigerant for the appropriate amount after the vacuum process is completed (Refer to next page "ADDITIONAL CHARGE").
- (5) Disconnect the service hoses and fit the cap to the charging valve.
- (6) Remove the blank caps, and fully open the spindles of the 3-way valves with a hexagon wrench.
- (7) Tighten the blank caps of the 3-way valves to the specified torque.

	Blank cap	Charging cap
Liquid pipe (3-way valve)	20.0 to 25.0 N·m	12.5 to 16.0 N·m
Gas pipe (3-way valve)	35.0 to 40.0 N·m	12.5 to 16.0 N·m

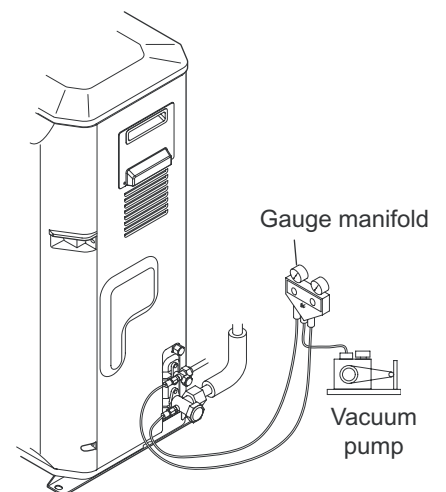
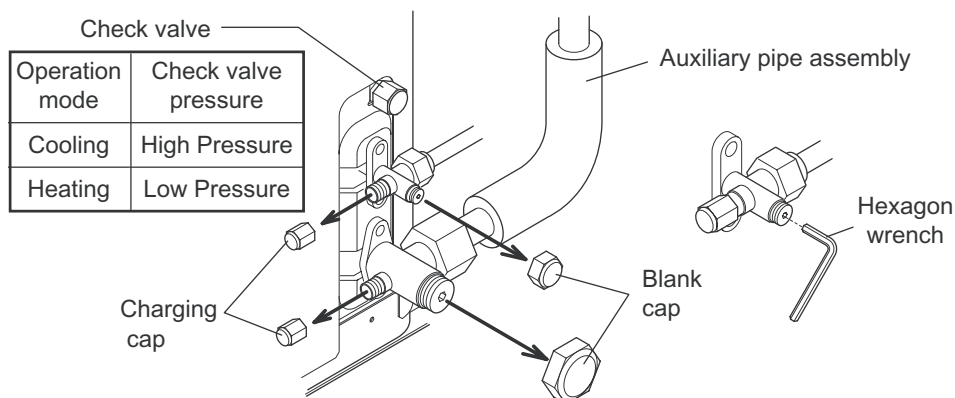

■ ADDITIONAL CHARGE

- * Always add the refrigerant for the appropriate amount.
Refer the additional refrigerant charge amount to item 5-1-4 "ADDITIONAL CHARGE CALCULATION".
- * Either larger or smaller refrigerant charge amount leads to the cause of trouble.
- * For after service purpose , the added refrigerant charge amount and the calculation shall be memorized.

⚠ CAUTION

When moving and installing the air conditioner, do not mix gas other than the specified refrigerant inside the refrigerant circuit.

When charging the refrigerant ,always use an electronic balance for refrigerant charging (to measure the refrigerant by weight).

Add refrigerant from the charging valve after the completion of the work.

The maximum length of the piping is 70 m (actual pipe length). If the units are further apart than this, correct operation can not be guaranteed.

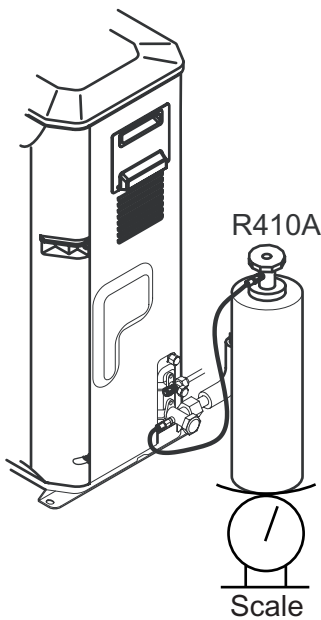

- * When you use scale, please use electronic scale with few errors.

5-6-4. ELECTRICAL WIRING

Always perform the installation referring to the installation instruction sheet, based on your local regions related laws and regulations, and electric company

⚠ WARNING

Before starting work, check that power is not being supplied to the outdoor unit.

Connect the connection cable firmly to the terminal board. Imperfect installation may cause a fire.

Always fasten the outside covering of the connection cable with the cord clamp. (If the insulator is chafed, electric leakage may occur.)

Always connect the ground wire.

Match the terminal board numbers of outdoor unit side with those of the indoor side. Improper connection will lead to malfunction or cause fuse blow.

• Connect wiring to the terminals

A. For solid core wiring (or F-cable)

Cut the wire end with a wire cutter or wire-cutting pliers, then strip the insulation to about 25 mm to expose the solid wire.

Using a screwdriver, remove the terminal screw(s) on the terminal board.

Using pliers, bend the solid wire to form a loop suitable for the terminal screw.

Shape the loop wire properly, place it on the terminal board and tighten securely with the terminal screw using a screwdriver.

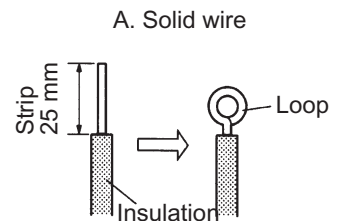

B. For strand wiring

Cut the wire end with a wire cutter or wire-cutting pliers, then strip the insulation to about 10 mm to expose the strand wiring.

Using a screwdriver, remove the terminal screw(s) on the terminal board.

Using a round terminal fastener or pliers, securely clamp a round terminal to each stripped wire end.

Position the round terminal wire, and replace and tighten the terminal screw using a screwdriver.

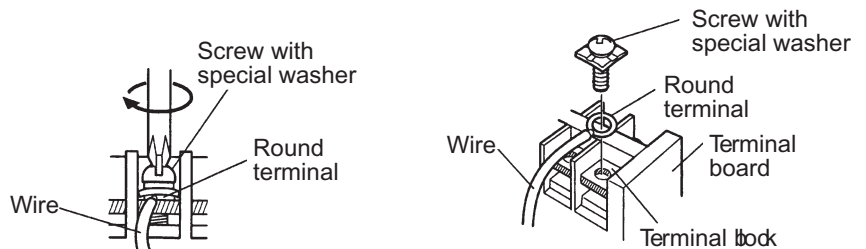
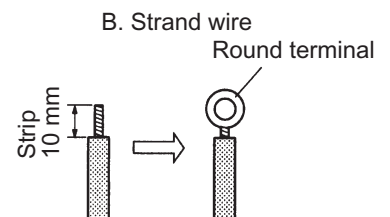

• Fix the connection cable and power supply cable at the cord clamp

After passing the connection cable and power supply cable through the insulation tube, fasten it with the cord clamp.

Use VW-1, 0.5 to 1.0mm thick, PVC tube as the insulation tube.

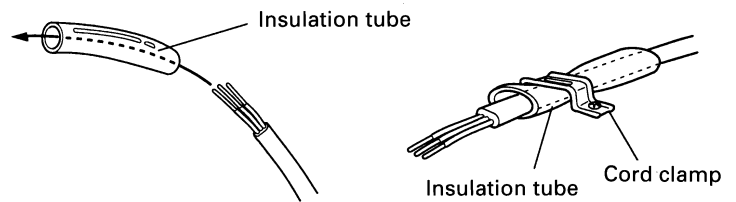

■ OUTDOOR UNIT

- (1) Remove the terminal cover of the outdoor unit, and connect the connection cable and the power supply cable to the terminal board.
- (2) Fasten the connection and power supply cable with the cord clamp, and install the terminal cover.

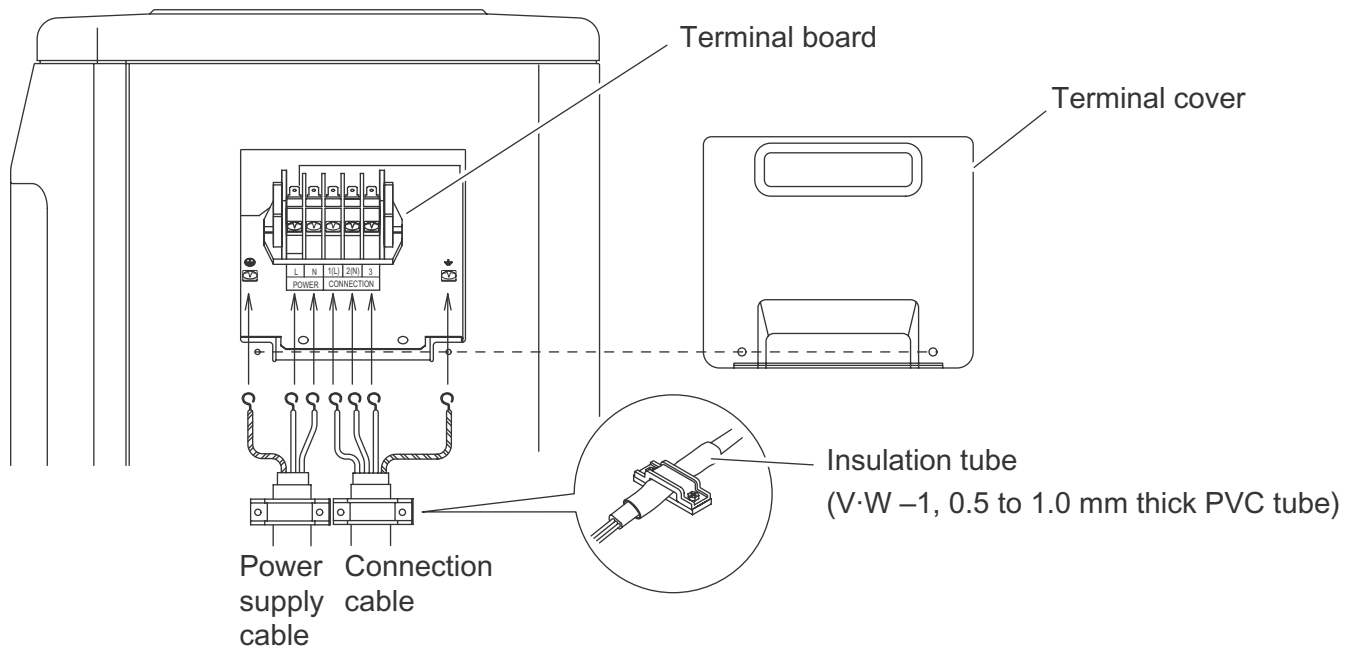

INDOOR UNIT

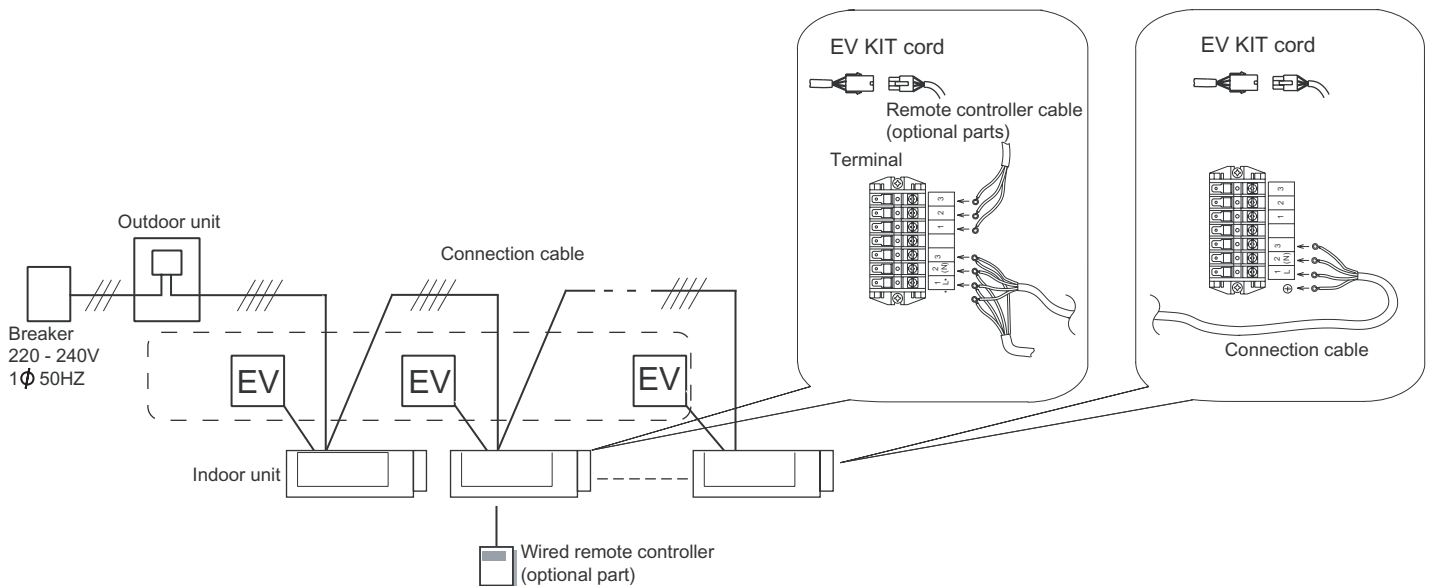

CAUTION

Never bundle the power supply cable or connection cable with remote controller cable together. Bundling these cables together will cause misoperation.

The power source capacity must be the sum of the air conditioner current and the current of other electrical appliances. When the current contracted capacity is insufficient, change the contracted capacity.

When the voltage is low and the air conditioner is difficult to start, contact the power company to raise electrical voltage.

WARNING

The rated voltage of this product is 220-240V A.C. 50 Hz. Before turning on verify that the voltage is within the 198 V to 264 V range.

Always use a special branch circuit and install a special receptacle to supply power to the air conditioner.

Use a circuit breaker and receptacle matched to the capacity of the air conditioner.

Perform wiring work in accordance with standards so that the air conditioner can be operated safely and positively.

Install a leakage circuit breaker in accordance with the related laws and regulations and electric company standards.

INSTALLING THE RECEIVER UNIT FOR DUCT TYPE INDOOR UNIT

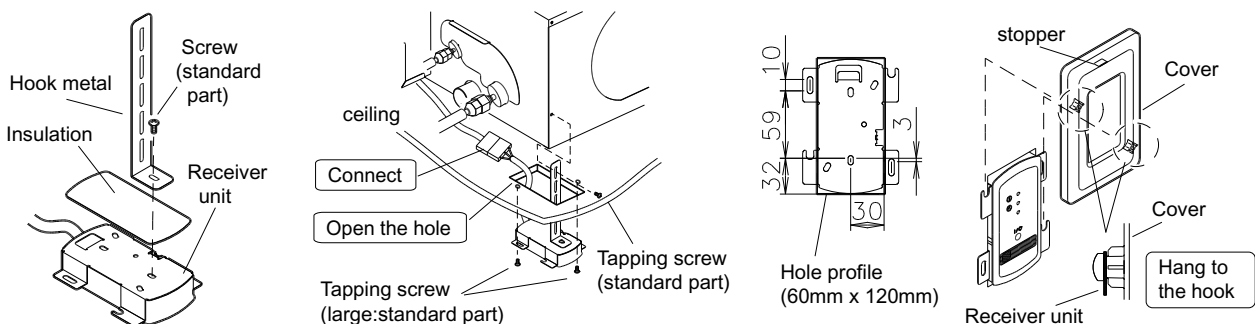

1 Fix Hook metal to Receiver unit by Screw putting in Insulation.

2 Open the hole to ceiling. Install Receiver unit by screw. Connect the connector.

3 Slide and set the cover to Receiver unit.

5-6-5. DRAIN PROCESSING

■ OUTDOOR UNIT

Please connect the hose when the processing of the drain water of the installation in the room etc. is necessary by the following method.

- * Since the drain water flows out of the outdoor unit during heating operation, install the drain pipe (STANDARD PARTS) and connect it to a commercial 16mm hose. (Heat pump model)
- * When installing the drain pipe, plug all the holes (• holes at seven places) other than the drain pipe mounting hole in the bottom of the outdoor unit with putty so there is no water leakage.
- * Make a space between bottom plate and the ground for the drain water.
- * Create ditch for the drain water around the outdoor unit if necessary.
- * Make sure that the drain hose is not lifted up, winding, or its end is not in the water.

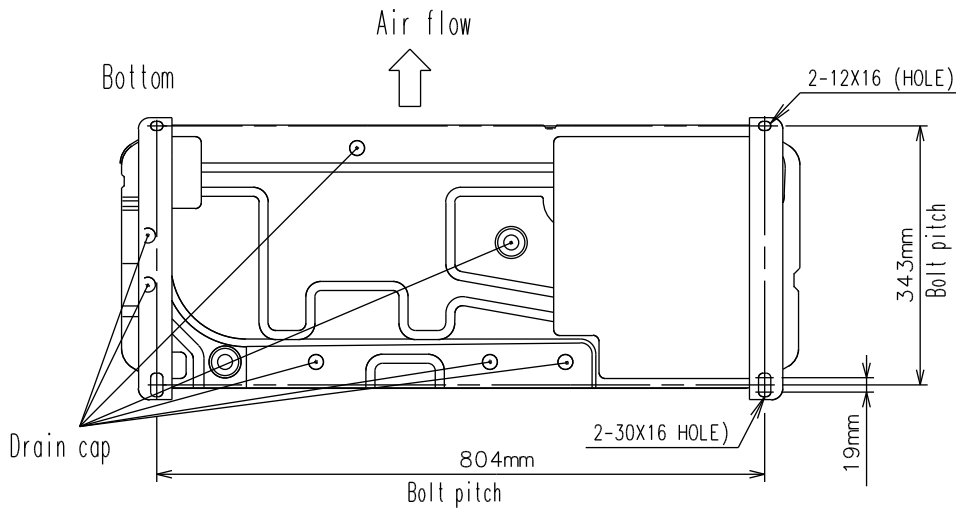

Drain pipe mounting hole

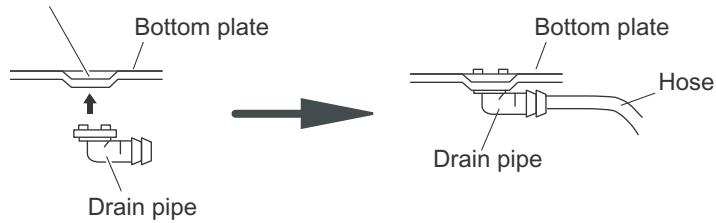

⚠ CAUTION

Installation in cold regions.
Install the drain hose so that it will not be packed or frozen.

INDOOR UNIT

NOTE : Install the drain pipe.

- * Install the drain pipe with downward gradient(1/50 to 1/100) and so there are no rises or traps in the pipe.
- * Use general hard polyvinyl chloride pipe (VP25) and connect it with adhesive (polyvinyl chloride) so that there is no leakage.
- * When the pipe is long, install supporters.
- * Do not perform air bleeding.
- * Always heat insulate the indoor side of the drain pipe.

COMPACT DUCT TYPE Drain port : O.D Ø26mm

A. CEILING SETTING

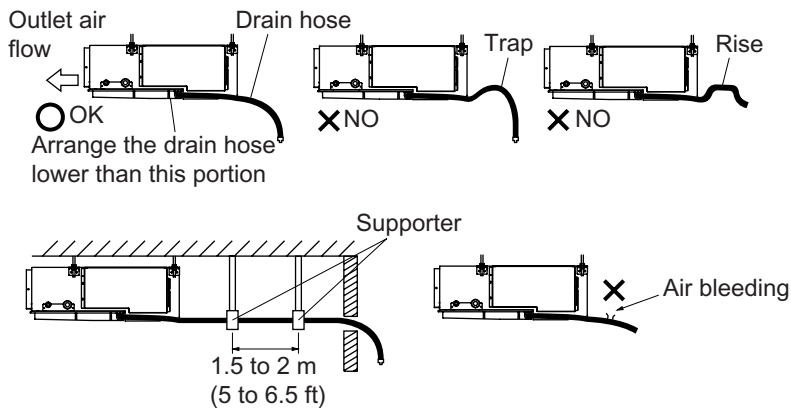

B. FLOOR STANDING SETTING

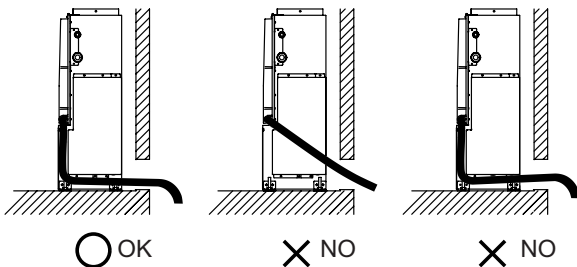

CAUTION

Connect the drain hose so that the control box cover can easily be removed for servicing when necessary.

In order to prevent water from leaking into the control box, make sure that the piping is well insulated.

After finishing the piping, the drain hose installation and the wiring, seal the holes in the wall.

LOW STATIC PRESSURE DUCT TYPE / DUCT TYPE

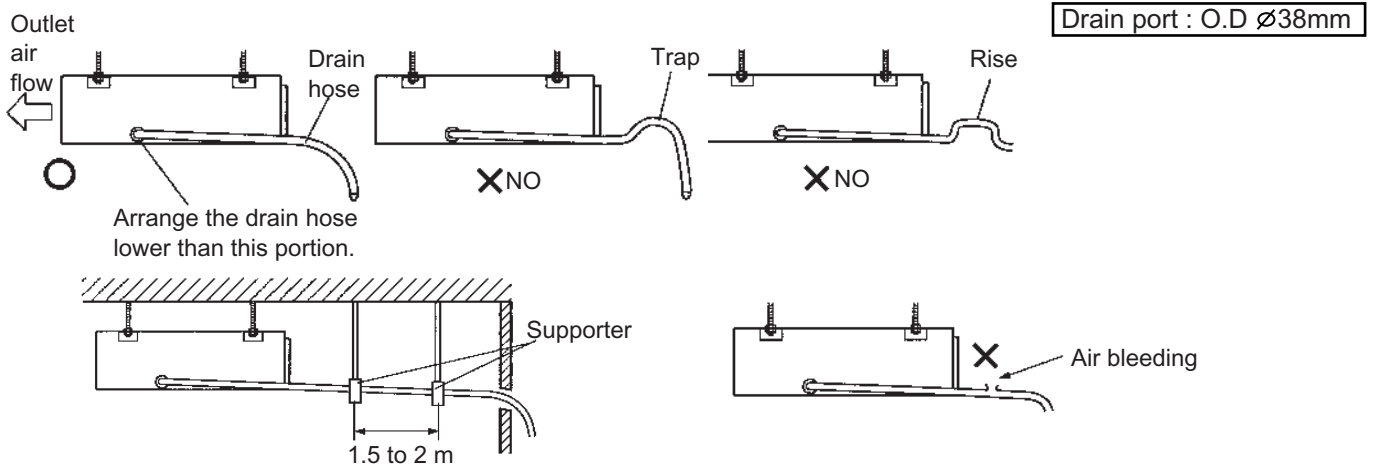

- * The outside diameter of the drain port is 38 mm. Use a suitable drain hose.
- * There is a drain port on both the left and right sides. Select the drain port to match the local conditions

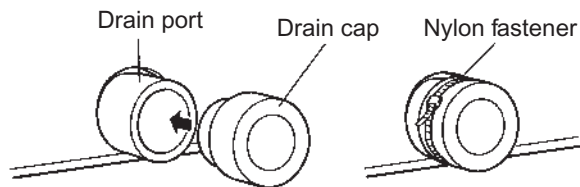
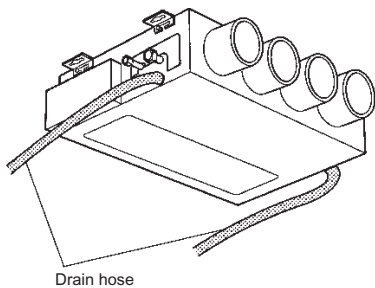

⚠ CAUTION

Always check that the drain cap is installed to the unused drain port and is fastened with the nylon fastener. If the drain cap is not installed, or is not sufficiently fastened by the nylon fastener, water may drip during the cooling operation.

COMPACT CASSETTE TYPE

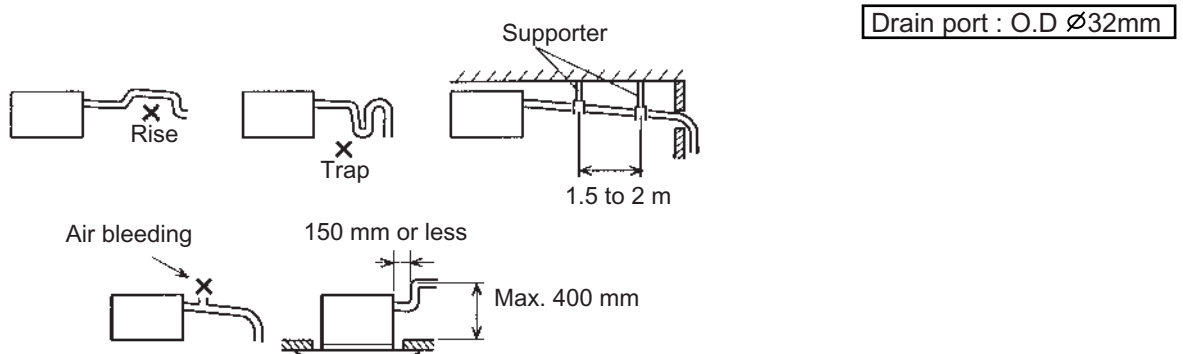

- * When desiring a high drain pipe height, raise it up to 400 mm or less from the ceiling within a range of 150 mm from the body.
- * A rise dimension over this range will cause leakage.

CASSETTE TYPE

Drain port : O.D \varnothing 32mm

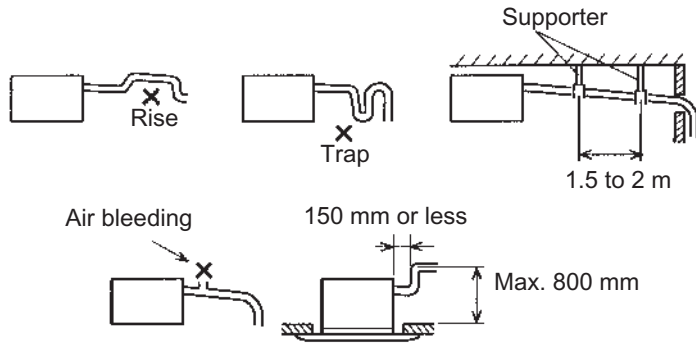

* When desiring a high drain pipe height, raise it up to 800 mm or less from the ceiling within a range of 150 mm from the body.

* A rise dimension over this range will cause leakage.

COMPACT WALL MOUNTED TYPE

Drain hose is attached.

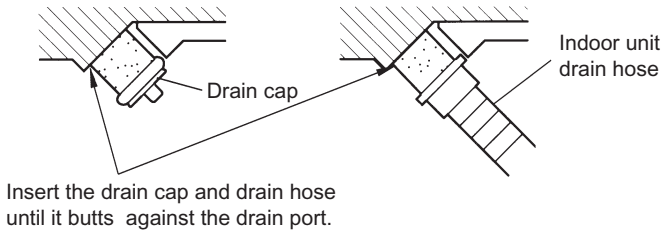

Check the following :

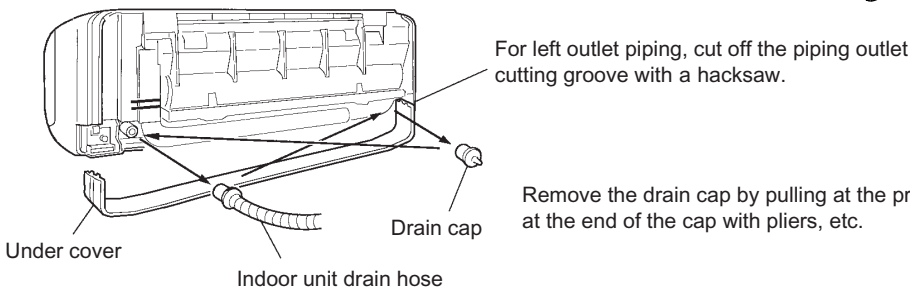
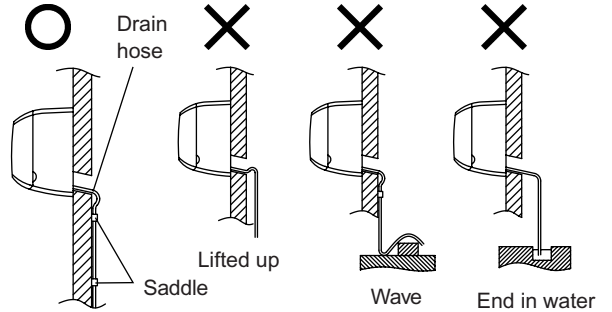

WALL MOUNTED TYPE

Drain hose is attached.

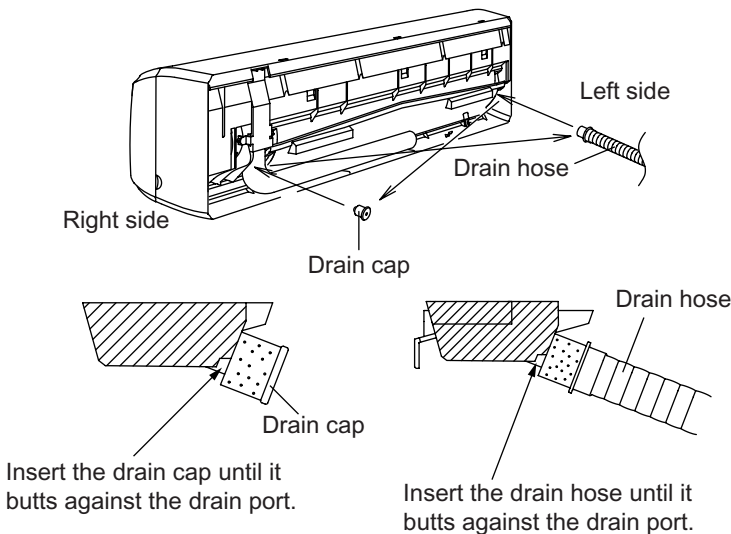

Check the following:

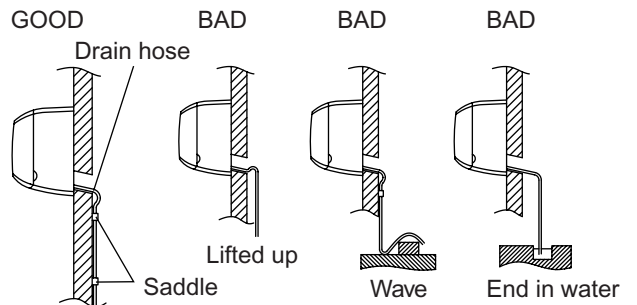

INSTALLATION

INSTALLATION

■ DRAIN PIPE INSULATION

- * Please confirm water is injected into Drain pan of the indoor unit, and drain is done normally when the connection of Drain hose is completed.
- * Please check whether there is water leak part in the Drain piping.
- * Please insulate it from heat by the heat insulator of enough thickness so that there is no be dewy when the confirmation ends. It causes the water leak like being imperfect.

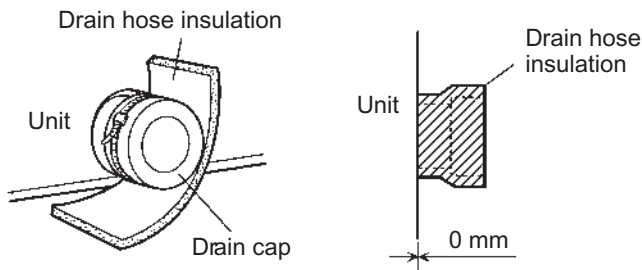
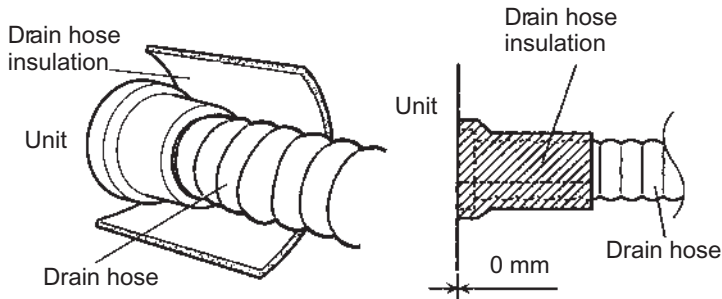

* Please roll the heat insulator also on the Drain cap side.(some models)

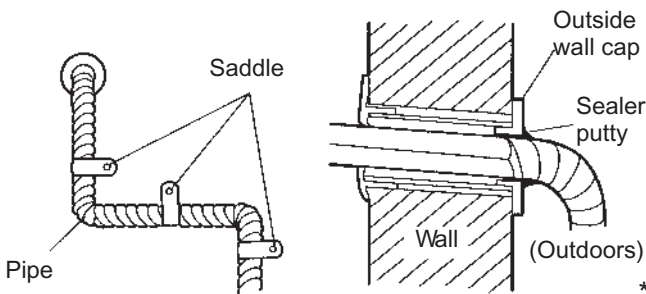

* Please cover the space with the putty etc. when you put out Drain hose from the wall.

■ CENTRAL DRAIN PROCESSING

When converging multiple drain pipes , install according to the procedure shown below.

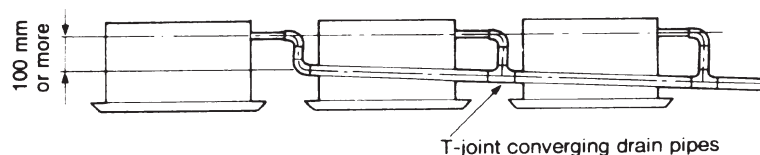

Select converging drain pipes whose gauge is suitable for the operating capacity of the unit.

5-6-6. DRAIN PUMP UNIT

■ MODEL : UTZ-PX1BBA

● Specifications

	Unit	Specifications
Height of drain up	mm	Maximum 1000
Power source	-	220 - 240V, 50 - 60Hz
Power input (230V, 50Hz/60Hz)	W	12 / 10.8
Current (230V, 50Hz/60Hz)	mA	114 / 92
Dimensions (H x W x D)	mm	176 x 178 x 154
Weight	kg	2.5
Connection pipe diameter	-	VP25 (I.D. 25mm, O.D. 32mm)
Direction of pipe connection *1	-	360°
Angle of pipe connection *2	-	0° (Horizontal) - 90°(Vertical)
Control method	-	Control board of Indoor unit
Safety device	-	Float switch, Thermal fuse

*1 Direction of pipe connection

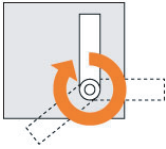

*2 Angle of pipe connection

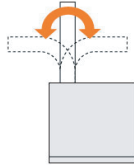

● Application indoor units

Type	Model
Compact Duct	AR07, AR09, AR12, AR14, AR18, AR22

● Mounting position

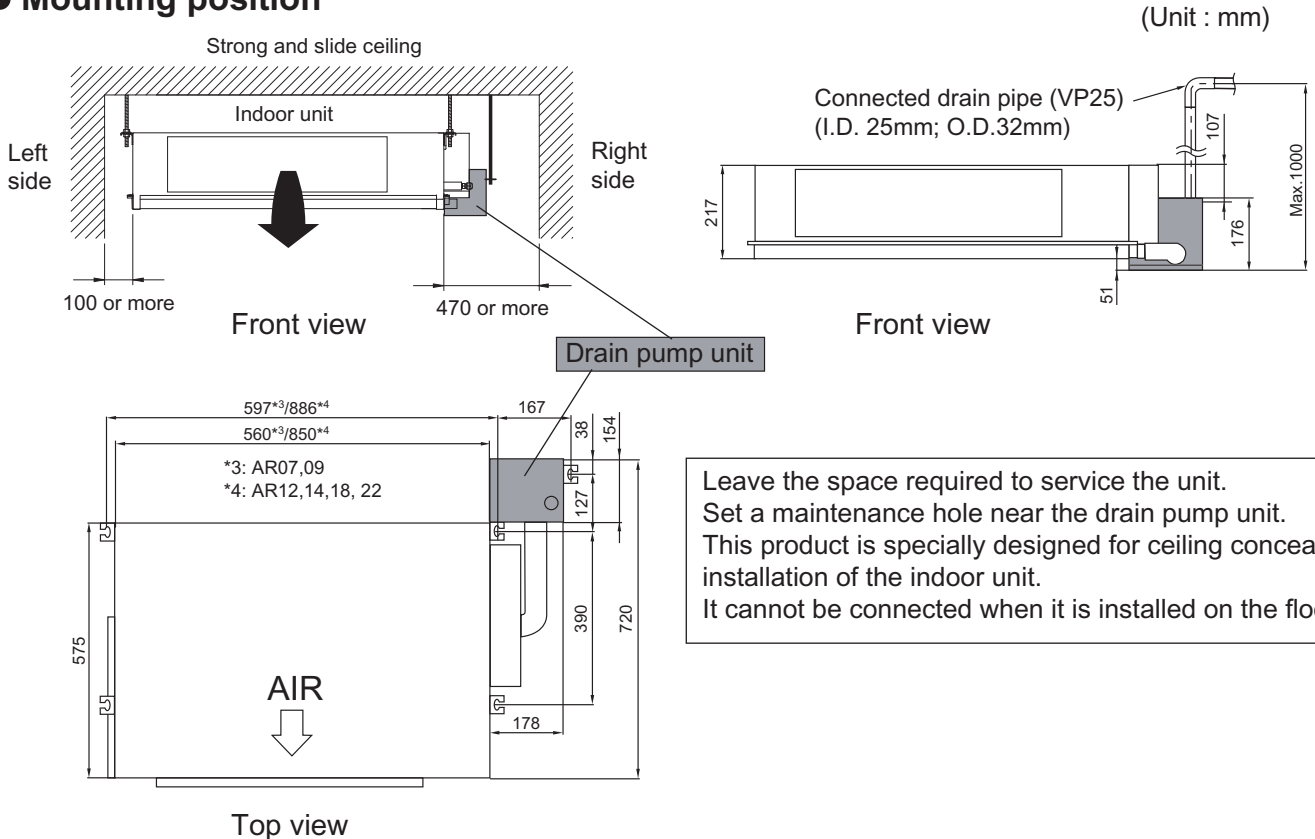

● Installing drain pump unit

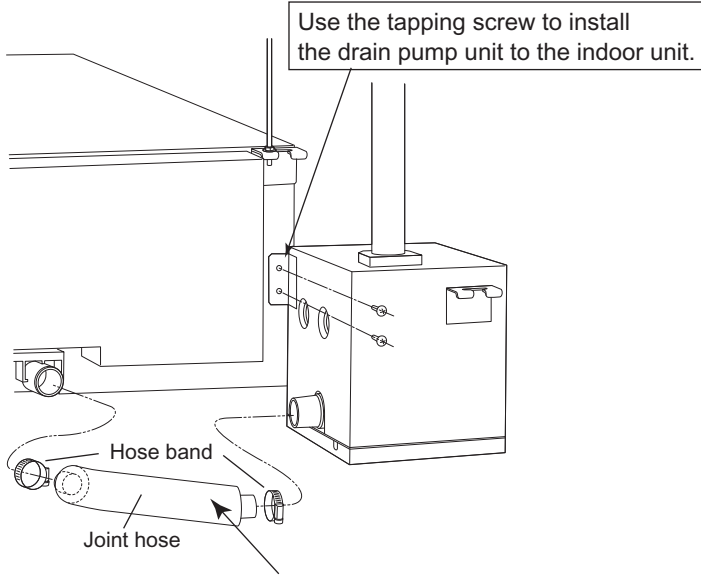

When there is no screw hole

Puncture holes at the following position and then install.

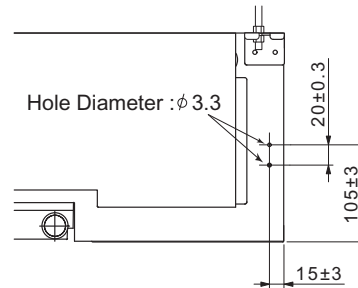

Thread the hose band through the joint hose, and insert it until it touches the drain pump unit and indoor unit.

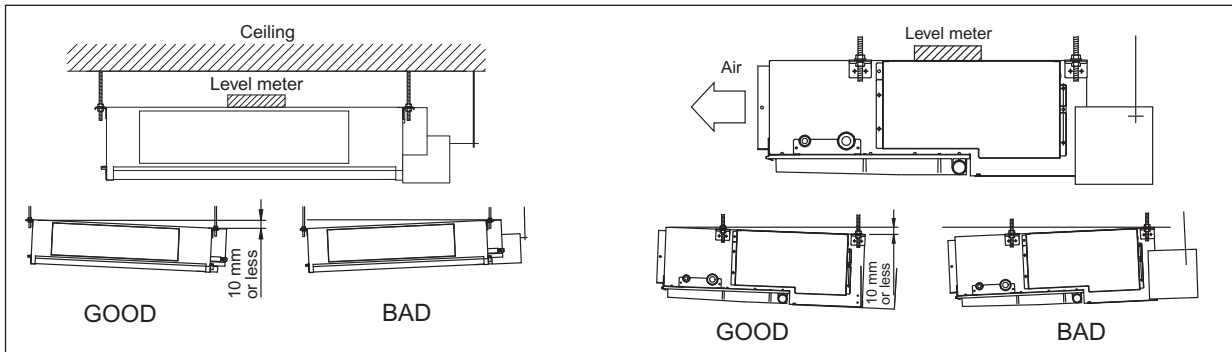

● Installing hose

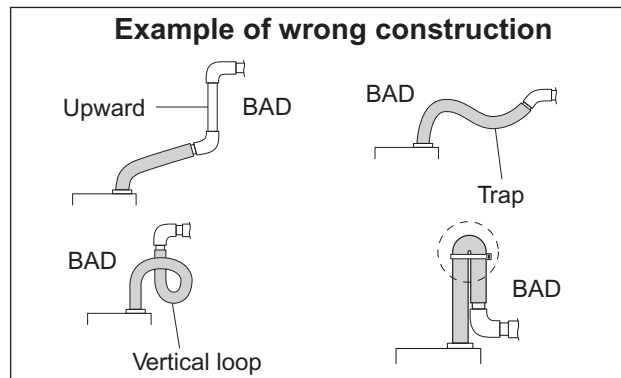
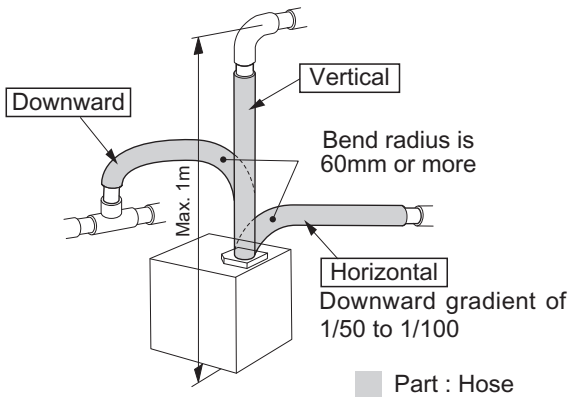

● Installing pipe

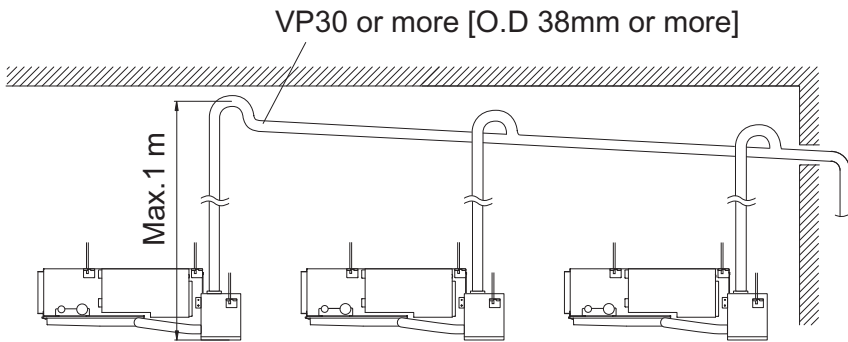
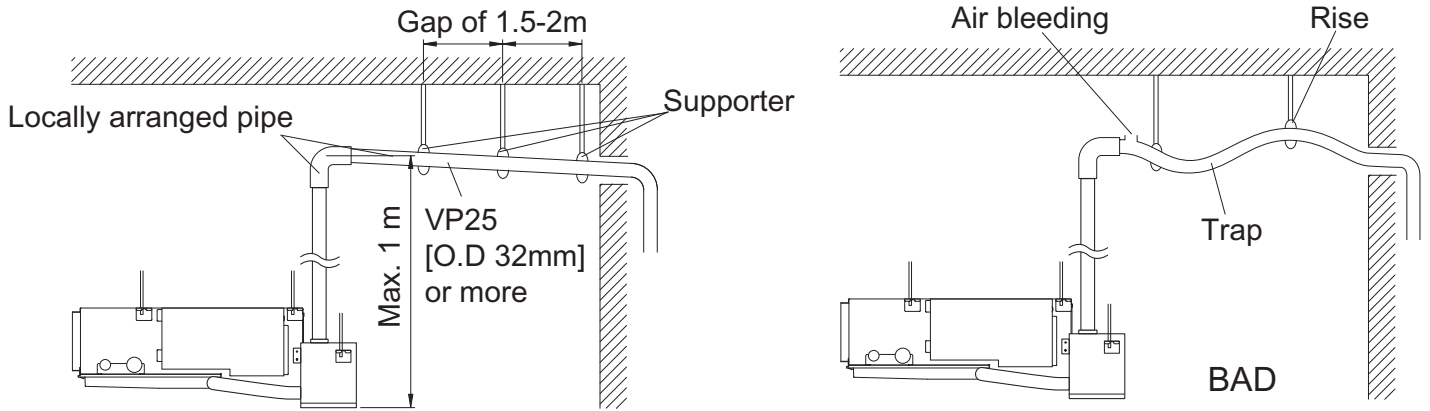

Observe the following procedures to construct centralized drain pipe fittings.

● Electrical wiring

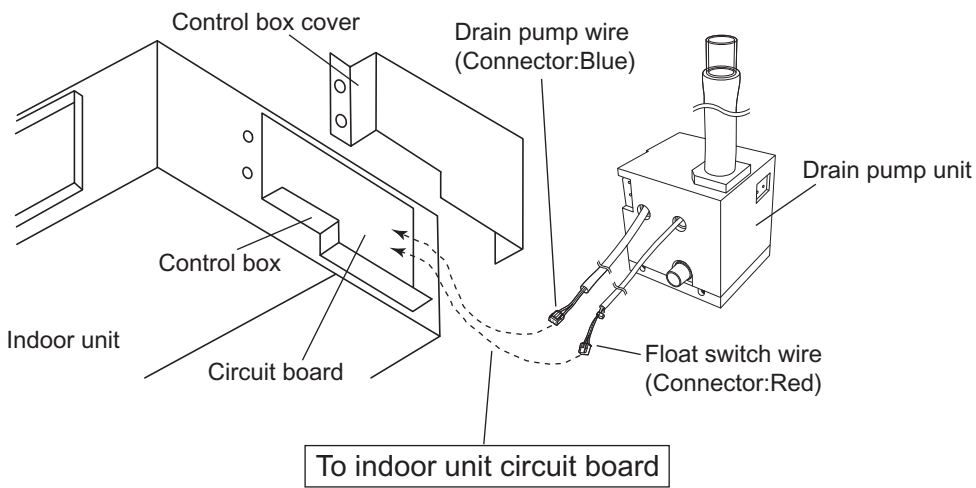

INSTALLATION

INSTALLATION

5-6-7. TEST RUN

■ TEST RUN METHOD

The procedures for performing the test run are described below.
(Supply power for at least 4 hours before starting operation in the winter.)

- (1) Perform a test run (cooling) separately for each indoor unit that is connected to the refrigerant system, and check the operation in order to confirm there is no problem on the wiring connection and the address.
- (2) Perform a test run (cooling) simultaneously for all indoor units are connected to the refrigerant system, and check the operation in order to confirm all installation is completed.

● Test operation using circuit board (Outdoor unit)

If the test operation is to be done for cooling operation, set DIP switch (SW1) to the corresponding system type as shown in the Table. After all the process have been completed, perform a test run.

	SW 1 - 1	SW 1 - 2
NORMAL OPERATING MODE	OFF	OFF
	ON	ON
COOLING MODE	ON	OFF
HEATING MODE	OFF	ON

● Test operation using remote controller

Short two metallic pieces in the remote controllers test run frame while the indoor unit is running. To stop the test run, push START/STOP button of the remote controller. When the air conditioner is being test run, the OPERATION and TIMER indicators flash slowly at the same time.

■ CHECK LIST

	Check item	Checking Method	Standard
1	After operating the indoor unit, the compressor operates?	Check operation sound and the LED of outdoor unit PCB.	Outdoor unit LED 3 :flushing
2	High pressure and low pressure are normal?	Confirm with a pressure gauge	Cooling : Low pressure 0.7 to 0.9MPa (approx.) Heating : High pressure 2.2 to 2.7 MPa (approx.)
3	Intake and outlet air Temperature of indoor unit are normal?	Check that there is a difference between the intake and outlet air temperatures.	Cooling : Below -10°C (approx.) Heating : Above 15°C (approx.)
4	Water is drained from drain hose or by the drain pump smoothly? (Only for cooling mode)	Check operation sound of the drain pump.	—
		Confirm water is draining.	—
5	Expansion valve of the stopped indoor unit are normal?	Check the refrigerant flows to the heat exchanger.(Wait at least 5 minutes after the indoor unit has stopped before checking the refrigerant.)	Cooling : No refrigerant flow Heating : A little refrigerant flow



5-7. STANDARD ACCESSORIES

The following installation parts are supplied. Use them as required.

5-7-1. OUTDOOR UNIT

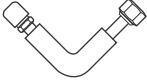

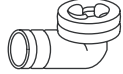



■ MODELS: AJ * A54L, AJ * A54J, AO * 54U, AO * 54F

Description	Q'ty	Application
Auxiliary pipe assembly 	1	For connecting the piping (Ø19.05)

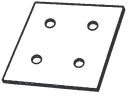

Description	Q'ty	Application
Drain pipe 	1	For outdoor unit drain piping work (Heat pump model only)
Drain cap 	7	For outdoor unit drain piping work (Heat pump model only)

5-7-2. INDOOR UNIT

■ COMPACT CASSETTE TYPE



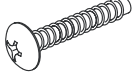





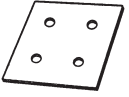

Name and Shape	Q' ty	Name and Shape	Q' ty
Installation template 	1	Remote controller 	1
Coupler heat insulation 	2	Remote controller holder 	1
Special nut (M10) 	4 (large)	Tapping screw 	3
	4 (small)		
Battery 	2		

GRILLE ACCESSORIES

Name and Shape	Q' ty
Bolt 	4
Washer 	4
Blower cover insulation 	2





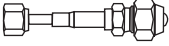





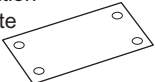



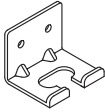

INSTALLATION

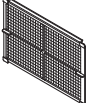
■ CASSETTE TYPE



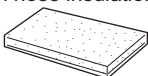

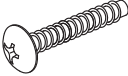





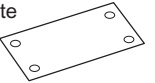





Name and Shape	Q ty	Name and Shape	Q ty	Name and Shape	Q ty	Name and Shape	Q ty
Installation template 	1	Remote controller 	1	Battery 	2	Remote controller holder 	1
Coupler heat insulation 	2	Tapping screw 	2	Blower cover insulation 	2	Hook wire 	2
Special nut (M10) 	4 (large)	Binder 	2 (large)	Reducer (for AU30 only) 	1		
	4 (small)		1 (small)				

INSTALLATION

■ COMPACT DUCT TYPE

Name and Shape	Q'ty	Name and Shape	Q'ty	Name and Shape	Q'ty	Name and Shape	Q'ty	Name and Shape	Q'ty
Installation template 	1	Special nut A (M10) (large flange) 	4	Remote controller 	1	Receiver unit 	1	Binder 	2 (small) 4 (large)
Hanger 	4	Special nut B (M10) (small flange) 	4	Remote controller holder 	1	Hook metal 	1	Filter 	2 (AR7/9) 3 (AR12/14 18/22)
Tapping screw (4X10) 	10	Coupler heat insulation (large) 	1	Battery 	2	Cover 	1		
Drain hose insulation 	1	Coupler heat insulation (small) 	1	Screw 	1	Tapping screw (large) 	2		

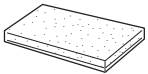





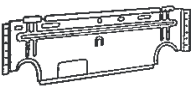
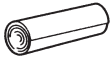

■ LOW STATIC PRESSURE DUCT TYPE / DUCT TYPE

Name and Shape	Q'ty	Name and Shape	Q'ty	Name and Shape	Q'ty	Name and Shape	Q'ty	Name and Shape	Q'ty
Installation template 	1	Special nut A (M10) (large flange) 	4	Remote controller 	1	Receiver unit 	1	Screw 	2 (Ø3×12) 2 (Ø4×20)
Hanger 	4	Special nut B (M10) (small flange) 	4	Remote controller holder 	1	Hook metal 	1		1 (Ø4×12) 1 (Ø4×10)
Binder 	5	Coupler heat insulation (large) 	1	Battery 	2	Cover 	1	Adopter Ø6.35-Ø9.52  AR30 type only	1
Drain hose insulation 	1	Coupler heat insulation (small) 	1	Insulation 	1				







INSTALLATION

INSTALLATION

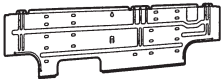
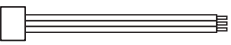
■ COMPACT WALL MOUNTED TYPE

Name and Shape	Q ty	Name and Shape	Q ty	Name and Shape	Q ty	Name and Shape	Q ty
Wall hook bracket 	1	Cloth tape 	1	Remote controller 	1	Remote controller holder 	1
Tapping screw (big) 	8	Seal A 	1	Tapping screw (small) 	2	Battery 	2
Binder 	2						

■ WALL MOUNTED TYPE

Name and Shape	Q ty	Name and Shape	Q ty	Name and Shape	Q ty	Name and Shape	Q ty
Wall hook bracket 	1	Wire assembly 	1	Remote controller 	1	Remote controller holder 	1
Tapping screw 	Big 12 Normal 4	EMI filter (ZCAT 1518-0730) 	1	Tapping screw 	Small 3	Battery 	2

INSTALLATION

INSTALLATION

5-8. REFRIGERANT LEAKAGE CAUTION

The installer and system specialist shall secure safety against leakage according to local regulations or standards. The following concentration limit may be applicable if local regulations are not available.

5-8-1. INTRODUCTION

Almost all our VRF(J series) type air conditioners use R410A as refrigerant. Though are harmless and incombustible in itself, the room in which the air conditioner is installed should be large enough that the refrigerant gas will not exceed the concentration limit even if the refrigerant gas leaks.

•Concentration limit

Concentration limit is the limit of Freon gas concentration where immediate measures can be taken without hurting the human body when refrigerant leaks in to the air. The concentration limit shall be described in units of Kg/m³ (Freon gas weight in /m³air) to facilitate calculation.

Concentration limit : 0.3kg/m³

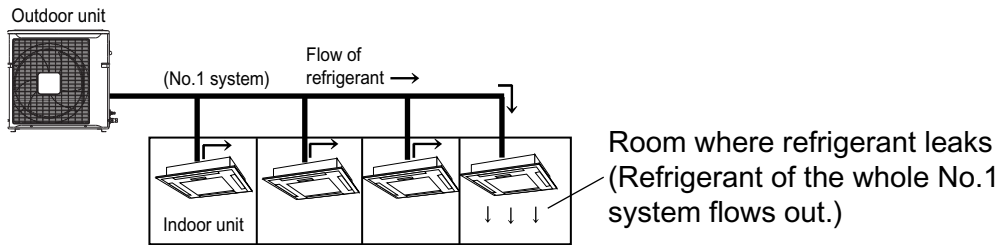

5-8-2. CHECKING CONCENTRATION LIMIT

Check concentration limit following steps ① ~ ②, and take appropriate measures depending on the situation.

- ① Calculate amount of all replenished refrigerant (kg) per refrigerant system.

Amount of replenished refrigerant per refrigerant system

Amount of replenished refrigerant at factory shipment

+

Amount of additional replenished refrigerant

Amount of additionally replenished refrigerant depending on piping length, and piping diameter at customer.

=

Total amount of replenished refrigerant in refrigerant facility (kg)

Note : When one refrigerant facility is divided into 2 or more refrigerant systems and each system is independent, total amount of replenished refrigerant of each system shall be adopted.

- ② Calculate minimum room capacity.
Calculate room capacity by regarding portion as one room or the smallest room.
- (a) Without partition

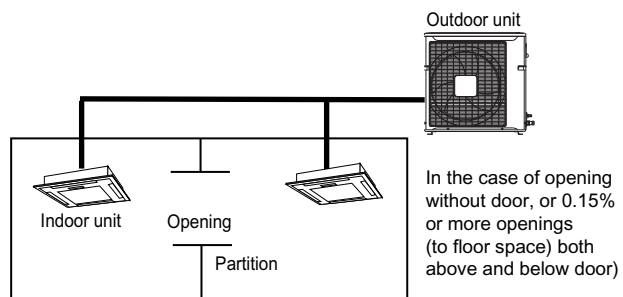
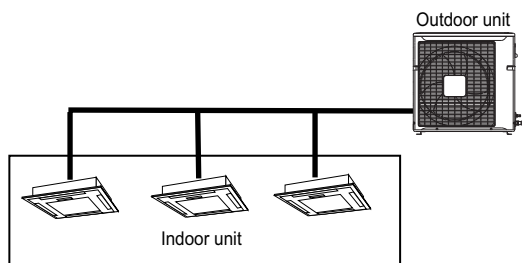

(b) With partition and without opening which serve as passage of air to adjoining room.

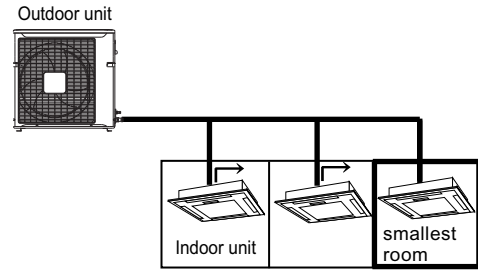

③ Calculate refrigerant concentration from the results of ① and ②

Total amount of replenished refrigerant in refrigerant facility(kg)

Capacity of smallest room where Indoor unit is installed(m³)

$$\frac{\text{Total amount of replenished refrigerant in refrigerant facility(kg)}}{\text{Capacity of smallest room where Indoor unit is installed(m}^3\text{)}} = \text{Refrigerant concentration(kg/m}^3\text{)}$$

(R410A)

When the result of calculation exceeds the limiting concentration, perform the same calculations by shifting to the second smallest, and the third smallest rooms until the final result is below the limiting concentration.

When concentration limit is exceeded

When the concentration limit is exceeded, change the original plan or take one of the countermeasures shown below.

- Countermeasure 1
Provide opening for ventilation.
Provide 0.15% or more opening to floor space both above and below or provide opening without door.
- Countermeasure 2
Provide gas leak alarm linked with mechanical ventilator.

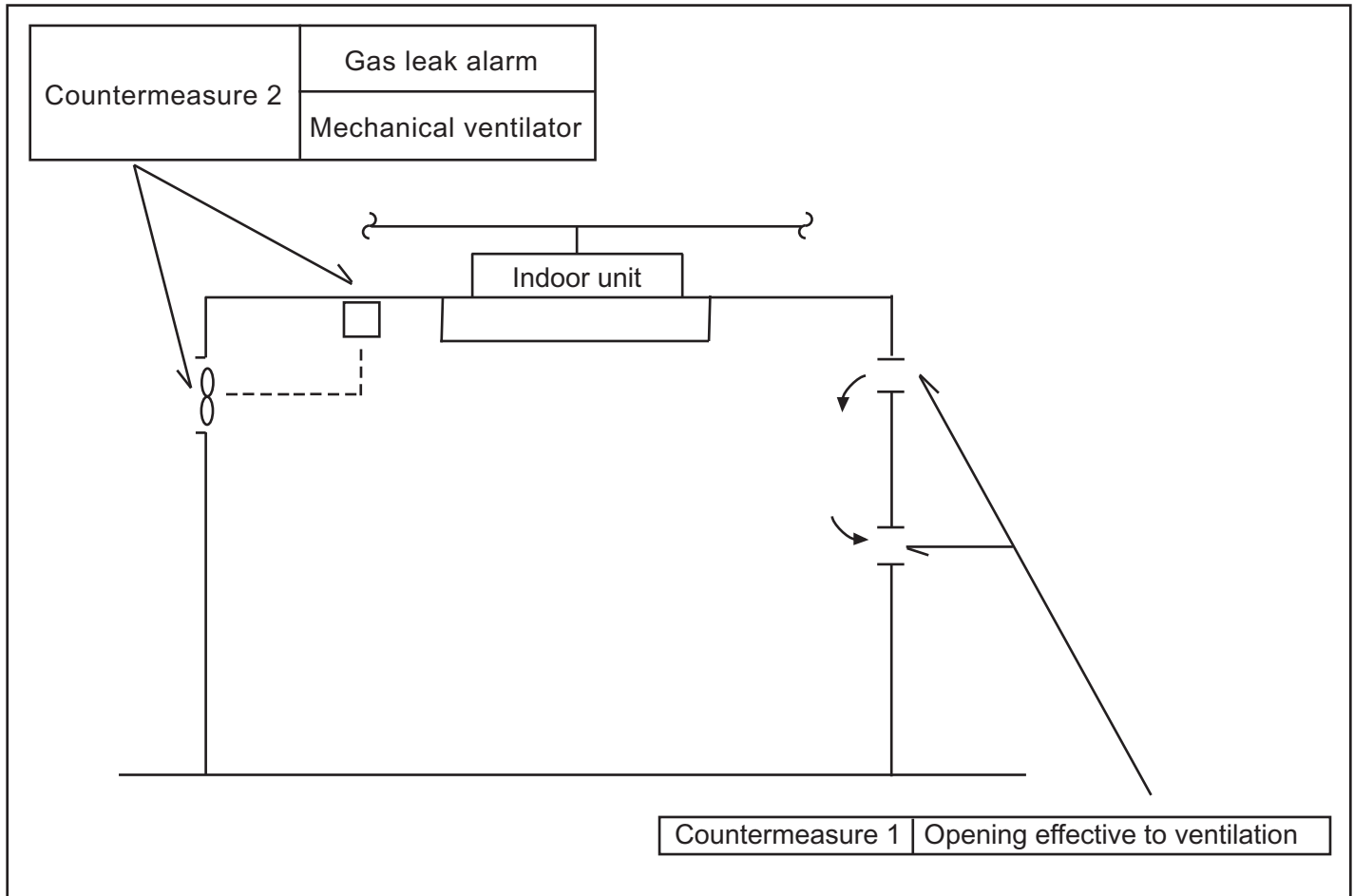

Pay special attention to the place, such as a basement, etc. When refrigerant can accumulate, since refrigerant is heavier than air.

AIRSTAGE™

J **SERIES**

6 . TROUBLE SHOOTING

6-1. OUTDOOR UNIT

■ NORMAL OPERATING MODE

Display Type	LED 1	LED 2	LED 3	LED 4	LED 5	LED 6
Not operating	⊙					
Cooling operation	⊙	○ (1)				
Heating operation	⊙	○ (2)				
Compressor frequency 20 to 30Hz	⊙		○ (1)			
Compressor frequency 31 to 40Hz	⊙		○ (2)			
Compressor frequency 41 to 50Hz	⊙		○ (3)			
Compressor frequency 51 to 60Hz	⊙		○ (4)			
Compressor frequency 61 to 70Hz	⊙		○ (5)			
Compressor frequency 71 to 80Hz	⊙		○ (6)			
Compressor frequency 81 to 90Hz	⊙		○ (7)			
Compressor frequency 91Hz —	⊙		○ (8)			
Pressure balance operation	⊙			⊙		
Oil recovery operation	⊙				○ (1)	
Defrosting operation	⊙				○ (2)	
Test run	⊙				○ (3)	
Pump down completed	⊙	○ (2)	○ (2)	○ (2)	○ (2)	○ (2)
SV1 open	⊙					○ (2)
SV2 open	⊙					○ (1)
Compressor rotation speed protection	⊙					○ (5)

Display Method ⊙ : Lighted continuously
 ○ : 0.5sec ON/0.5sec OFF flashing
 () : Flashing times

Note : LED4 may be lighted occasionally in the pattern not shown in the table.
 However this is not a problem.

● Operation display

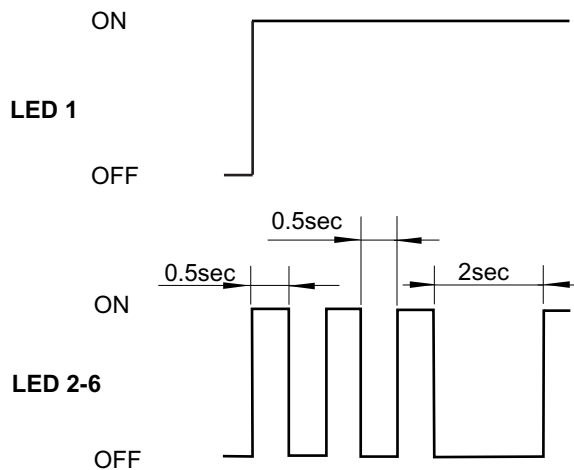

● Outdoor printed circuit board layouts

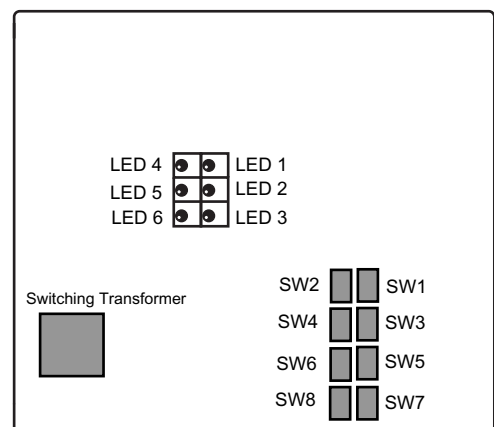

TROUBLE SHOOTING

TROUBLE SHOOTING

■ ABNORMAL MODE

Display type	LED 1	LED 2	LED 3	LED 4	LED 5	LED 6
Discharge temperature error	◇	● (4)				
High-pressure error	◇	● (7)				
Low-pressure error	◇	● (8)				
Pump down error (High-pressure error)	◇	● (9)				
Pump down error (Discharge temperature error)	◇	● (10)				
Pump down error (Others)	◇	● (11)				
Discharge temperature thermistor error	◇		● (1)			
Heat exchanger liquid temperature thermistor error	◇		● (4)			
Suction temperature thermistor error	◇		● (10)			
Outdoor temperature thermistor error	◇		● (11)			
Heat exchanger temperature thermistor (middle) error	◇		● (6)			
Pressure switch 1 (HP) error	◇			● (1)		
Pressure switch 2 (LP) error	◇			● (2)		
Compressor rotor location detection error	◇			● (4)		
Electric current trip error	◇			● (5)		
CT error	◇			● (6)		
Trip terminal L start-up error	◇			● (9)		
Power source frequency abnormal	◇				● (2)	
EEPROM error	◇				● (3)	
Microcomputers communication error	◇				● (7)	
Network communication error	◇				● (8)	
Indoor unit error	◇					● (1) : unit0 ● (2) : unit1 ● (3) : unit2 ● (4) : unit3 ● (5) : unit4 ● (6) : unit5 ● (7) : unit6 ● (8) : unit7

Display method {
 ◇ : 0.1 sec ON / 0.1 sec OFF flashing
 ● : 0.3 sec ON / 0.3 sec OFF flashing
 () : Flashing times

● Error display

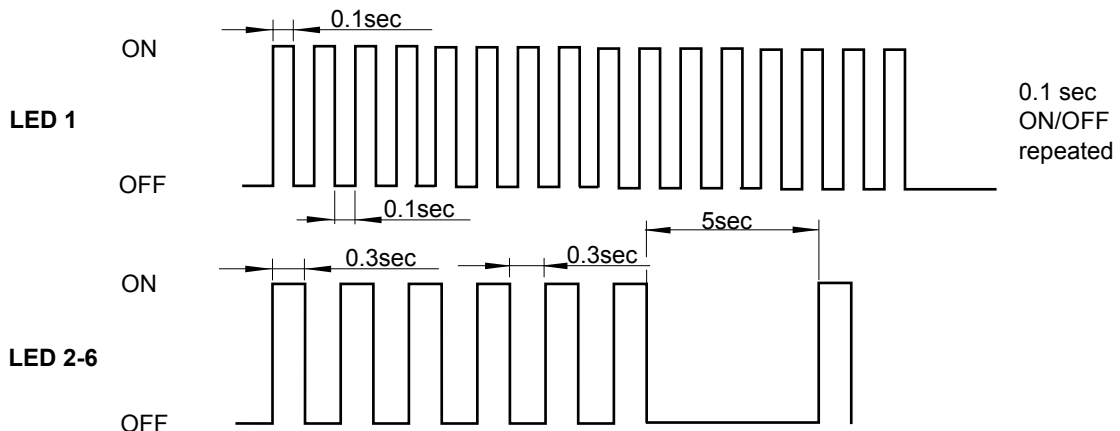

TROUBLE SHOOTING

TROUBLE SHOOTING

6-2. INDOOR UNIT

Error display			Error code	Error contents
OPERATION indicator	TIMER indicator	3rd (SWING) indicator		
———	———	———	E : 00	
0.1sec ON/OFF	0.1sec ON/OFF	———	E : 02	Model information abnormal
0.1sec ON/OFF	0.1sec ON/OFF	0.1sec ON/OFF	E : 04	Power supply frequency abnormal
2 times flashing	0.1sec ON/OFF	———	E : 09	Room temperature thermistor error
3 times flashing	0.1sec ON/OFF	1 times flashing	E : 0b	Indoor unit heat exchanger thermistor (inlet) error
3 times flashing	0.1sec ON/OFF	2 times flashing	E : 0A	Indoor unit heat exchanger thermistor (middle) error
4 times flashing	0.1sec ON/OFF	———	E : 11	Drain abnormal
5 times flashing	0.1sec ON/OFF	1 times flashing	E : 18	Communication error 1 (indoor unit ↔ Wired / Simple remote controller)
5 times flashing	0.1sec ON/OFF	2 times flashing	E : 03	Microcomputer error
5 times flashing	0.1sec ON/OFF	4 times flashing	E : 18	Communication error 2 (indoor unit ↔ Wired / Simple remote controller)
6 times flashing	0.1sec ON/OFF	———	E : 13	Indoor unit fan error
0.1sec ON/OFF	3 times flashing	3 times flashing	E : 32	Outdoor unit error
0.1sec ON/OFF	4 times flashing	1 times flashing	E : 06	EEPROM access error
0.1sec ON/OFF	4 times flashing	2 times flashing	E : 07	EEPROM deletion error
0.1sec ON/OFF	5 times flashing	1 times flashing	E : 1F	Transmission error
0.1sec ON/OFF	6 times flashing	———	E : 21	Parallel communication error

6-3. WIRED, SIMPLE REMOTE CONTROLLER

Error cord	Error contents
E : 00	No error
E : 02	Model information abnormal
E : 03	Micro computer error
E : 04	Power supply frequency abnormal
E : 06	EEPROM access error
E : 07	EEPROM deletion error
E : 09	Room temperature thermistor error
E : 0A	Indoor unit heat exchanger thermistor (middle) error
E : 0b	Indoor unit heat exchanger thermistor (inlet) error
E : 11	Drain abnormal
E : 13	indoor unit fan error
E : 18	Communication error 1 (Indoor unit ↔ wired/simple Communication error 2 remote controller)
E : 1F	Transmission error
E : 21	Parallel communication error
E : 32	Outdoor unit error

6-4. GROUP REMOTE CONTROLLER

■ GROUP REMOTE CONTROLLER

Error Code	Outdoor unit error	Indoor unit error	Group remote controller error Converter error
00	No error	No error	No error
01	—	—	—
02	Model information abnormal	Model information abnormal	—
03	Microcomputer communication error	Microcomputer communication error	Microcomputer communication error
04	Power supply frequency abnormal	Power supply frequency abnormal	—
05	—	—	Parallel communication error
06	EEPROM access error	EEPROM access error	EEPROM access error
07	EEPROM deletion error	EEPROM deletion error	—
08	—	—	—
09	Compressor 1 error	Room temperature thermistor error	—
0A	Compressor 2 error	Heat exchanger thermistor (middle) error	—
0b	Compressor 3 error	Heat exchanger thermistor (inlet) error	—
0C	—	Heat exchanger thermistor (outlet) error	—
0d	Discharge temperature thermistor 1 error	Blower temperature thermistor error	—
0E	Discharge temperature thermistor 2 error	—	—
0F	Discharge temperature thermistor 3 error	—	—
10	Outdoor temperature thermistor error	—	—
11	Heat exchanger inlet thermistor 1 error	Drain abnormal	—
12	Heat exchanger inlet thermistor 2 error	Room temperature abnormal	—
13	Heat exchanger inlet thermistor 3 error	Indoor unit fan error	—
14	Heat exchanger outlet thermistor 1 error	—	—
15	Heat exchanger outlet thermistor 2 error	—	—
16	Heat exchanger outlet thermistor 3 error	—	—
17	Suction temperature thermistor error	—	—
18	—	Standard wired remote control communication error	—
19	Discharge pressure sensor error	—	—
1A	Liquid pressure sensor error	—	Address setting error
1b	Suction pressure sensor error	—	—
1C	Oil sensor error	—	Connection error
1d	—	—	System error
1E	—	—	—
1F	Transmission error	Transmission error	Transmission error
20	—	—	—
21	Discharge temperature 1 error	—	—
22	Discharge temperature 2 error	—	—
23	Discharge temperature 3 error	—	—
24	High-pressure error	—	—
25	Low-pressure error	—	—
26	—	—	—
27	Oil recovery error	—	—
28	Pump down error	—	—

■ NETWORK CONVERTOR

Error code	Error contents
	Normal
	System malfunction
	Main circuit board maintenance error
	Middle circuit board connected incorrectly
	Bottom circuit board connected incorrectly
	Middle circuit board maintenance error
	Bottom circuit board maintenance error

● Circuit board and LED layouts

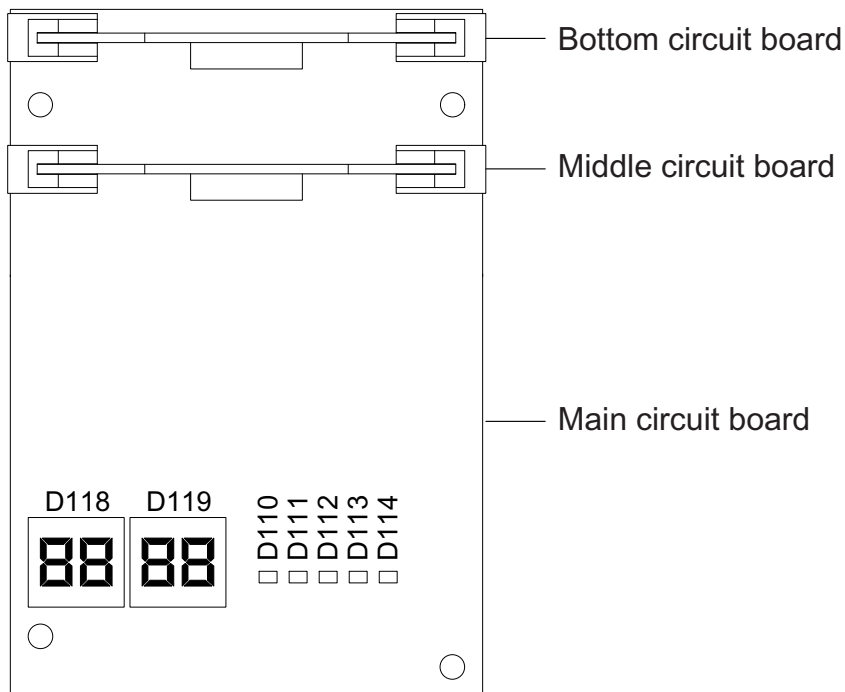

6-5. CASES SUCH AS THESE ARE NORMAL

■ Operation not trouble

From the standpoint of control, the following operations are incorporated for air conditioner operation and protection. They do not indicate trouble.

Operation		Description	Indoor unit	Remote indication
Red and green lamps flash alternately.		Indicates that the power came on normally when power was applied (at power failure recovery). Indication is cleared by RUN command.	The red and green lamps flash alternately in the operation stop state.	
		When test run is performed, the unit operates without regard to the temperature setting. Stopped by remote controller stop. or reset after 60 minutes.	The red and green lamps flash simultaneously in the operation state.	TEST
Red lamp flashes.		Operation is stopped and refrigerant is passed through the indoor unit to remove the outdoor unit frost (defrosting operation) or to recover the refrigerant oil (oil recovery operation). The indoor unit stops in about 5-10 minutes.	The fan stops and the refrigerant passes through. The red lamp flashes slowly.	DEFROST
Indoor unit fan does not operate even through the RUN signal has entered.		The fan is stopped to prevent blowing out of cold air when the machine is still not warm at the start of heating operation. About 3 minutes are necessary.	The fan stops and the red lamp lights steadily.	
Fan turns on/off periodically.		When the room temperature at heating operation reaches the set temperature, the FAN is stopped and room temperature rise is prevented. At this time, the fan is operated periodically to detect the room temperature. (4 minutes stop, 1minute operate)	The fan continues to operate and the red lamp lights steadily.	
RUN signal is input, but is not accepted. Buzzer sounds.		When an [AUTO], [FAN] and an operation other than the operation another indoor unit is already performing at cooling/heating selection type or [HEAT] operation at a cooling only unit is commanded, operation cannot be performed at that setting.	Buzzer buzzes 5 times and setting is not received. Operation before setting continues.	
Makes a sound even after operation stops.		After cooling operation stops, the drain pump is operated. Remains for 3 minutes.		
Makes a sound while operating.	Flowing liquid sound during operation	A sound changed by the refrigerant flow may be made by operation of another indoor unit connected to the same outdoor unit. A switching sound may be made at the start and after the end of defrosting operation and oil recovery operation.		
	Squeaking sound	This is due to expansion and contraction of resin parts by the temperature change during heating operation and oil recovery operation.		
	Switching sound	A sound is generated when the internal valve is switched at operation switching and at the start of defrosting operation and oil recovery operation.		

When operation and indication other than the above occurs, call the manager.

AIRSTAGE™

J SERIES

7 . OPTIONAL PARTS

7-1. SEPARATION TUBE

■ UTR-BP054X / UTR-BP54U

(UNIT: mm)

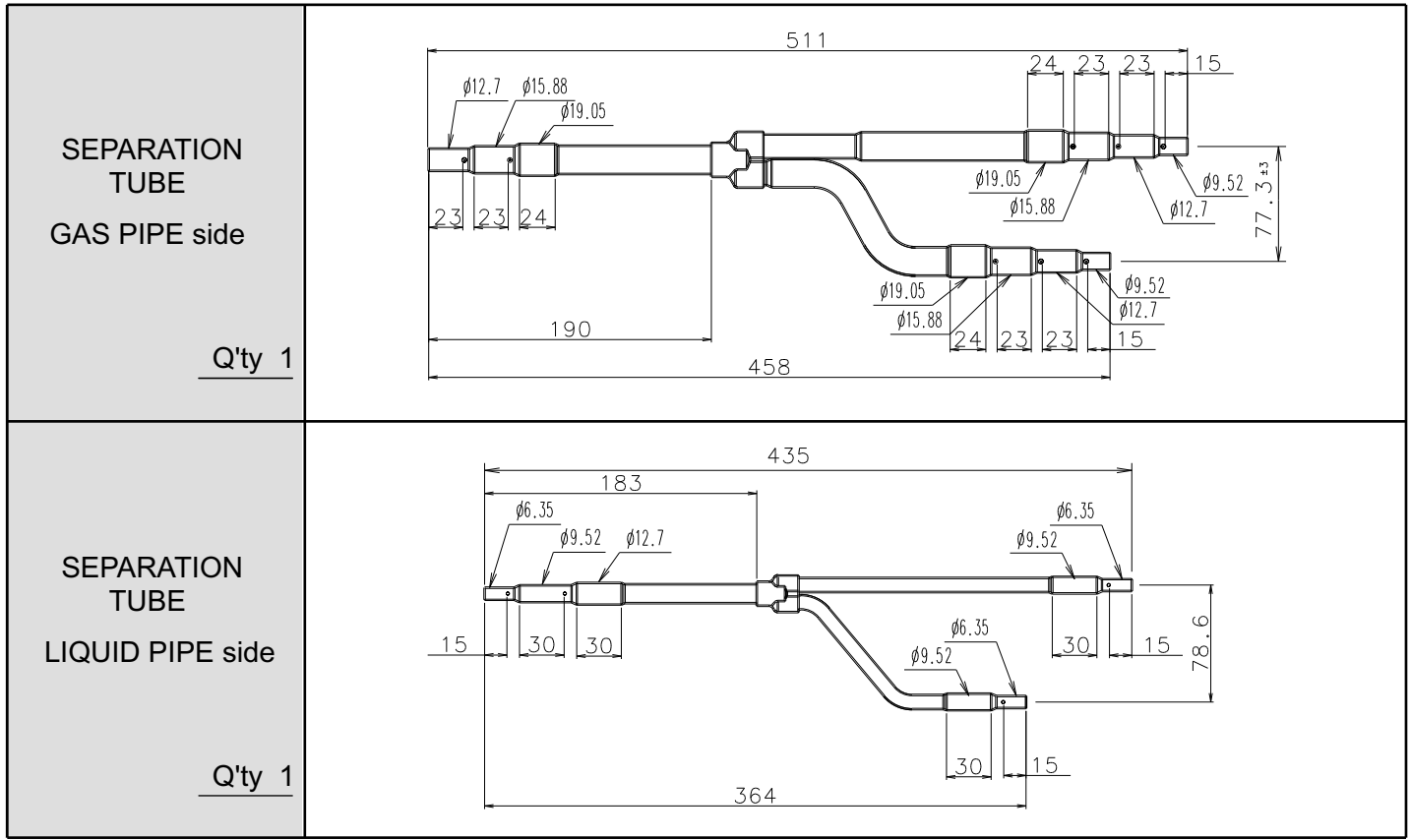

● Heat insulation

Heat insulation	Q'ty	Application
	2	Large x 1 (for gas pipe)
		Small x 1 (for liquid type)

Tape	Q'ty
 for UTR-BP054X only	8

Binder	Q'ty
 for UTR-BP54U only	4

OPTIONAL PARTS

OPTIONAL PARTS

7-2 HEADER

■ UTR - HD546U

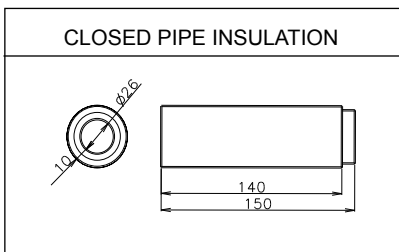
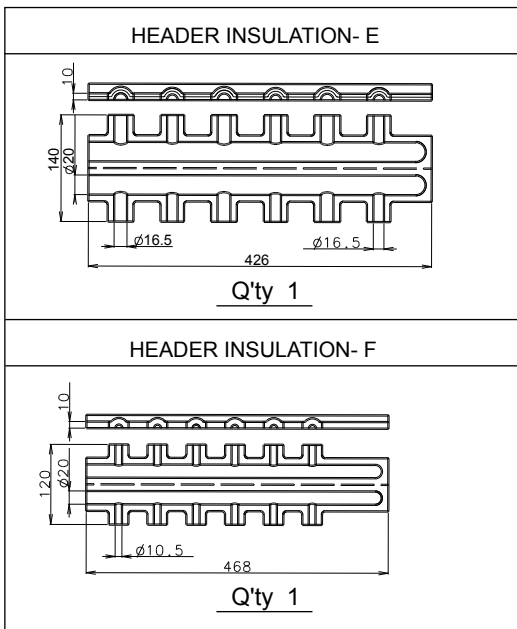
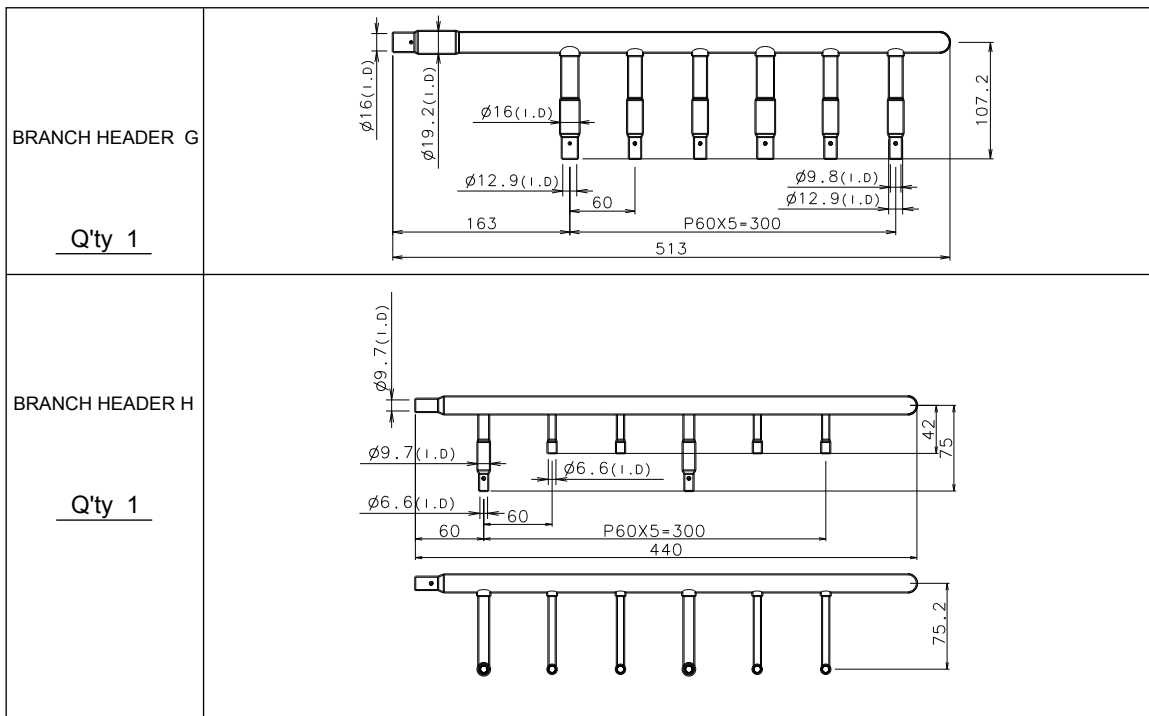

OPTIONAL PARTS

OPTIONAL PARTS

7-3. EV KIT

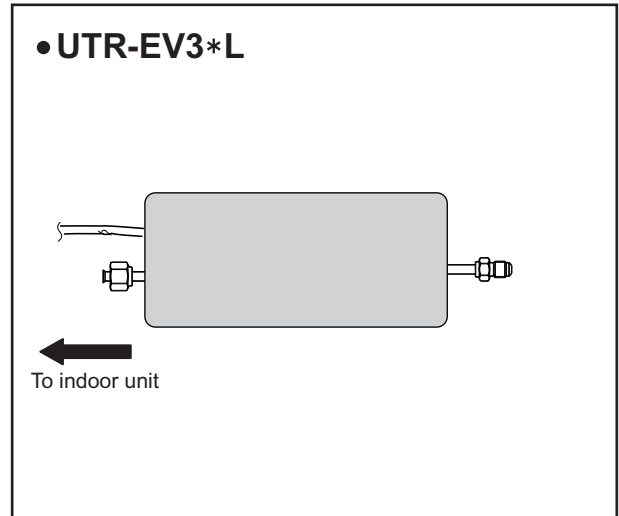
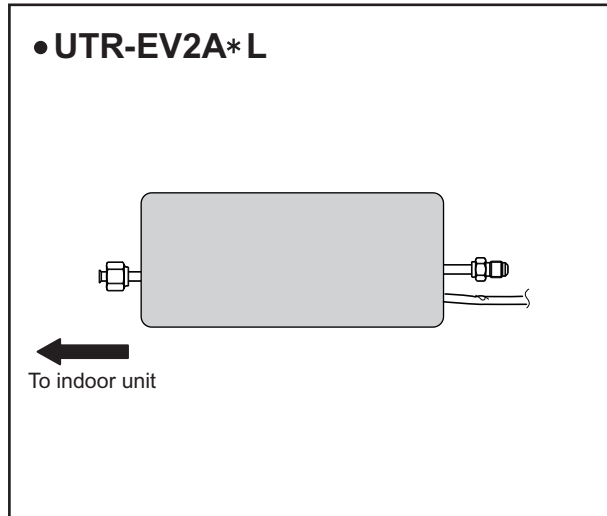

	H x W x D (mm)	Connect to liquid pipe outside diameter. (mm)
UTR - EV2A*L	83 x 288 x 45	6.35
UTR - EV3*L	97 x 290 x 50	9.52

7-4. CONTROLLER

■ WIRELESS REMOTE CONTROLLER

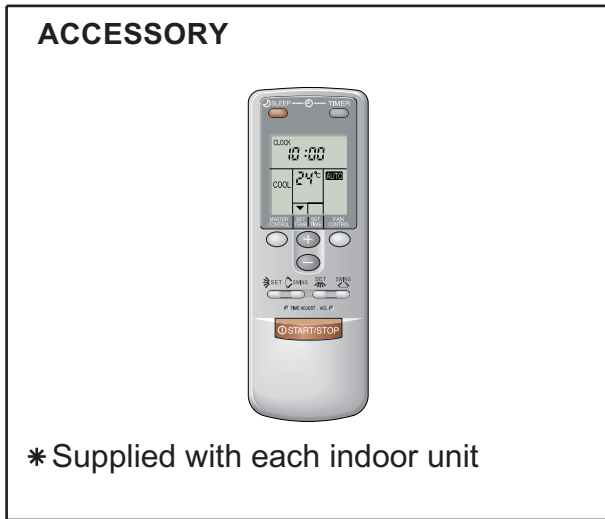

■ IR RECEIVER UNIT

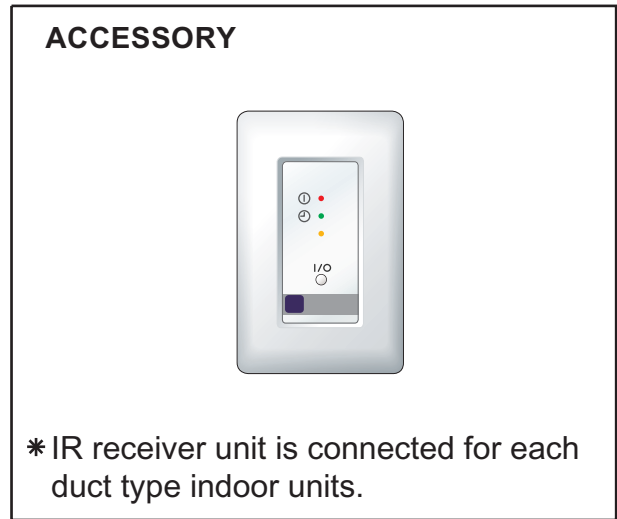

■ WIRED REMOTE CONTROLLER

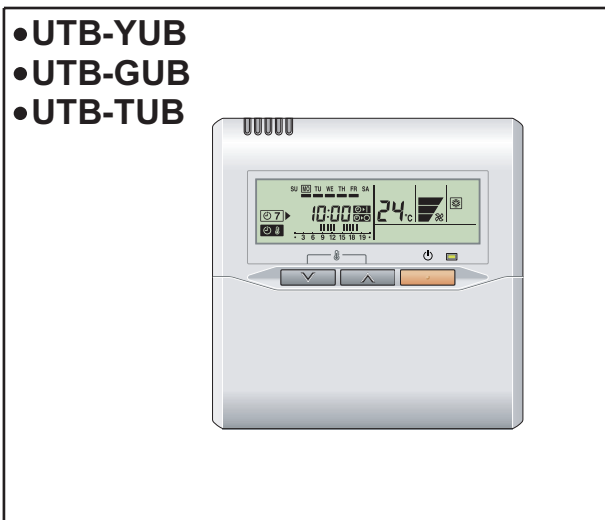

■ SIMPLE REMOTE CONTROLLER

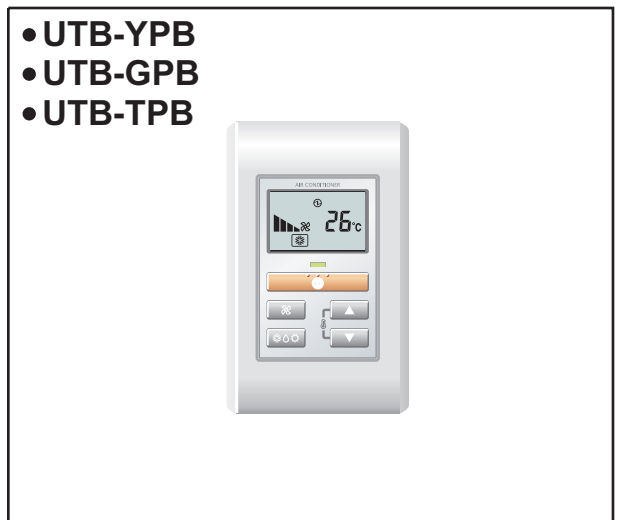

■ SIMPLE REMOTE CONTROLLER

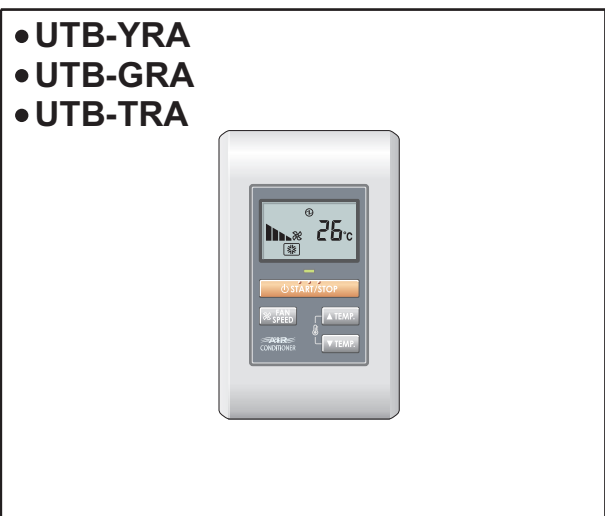

■ GROUP REMOTE CONTROLLER

- UTB-YDB
- UTB-GDB

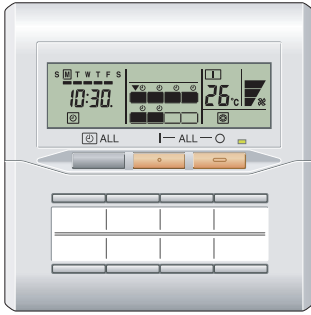

■ NETWORK CONVERTOR

- UTR-YGCA

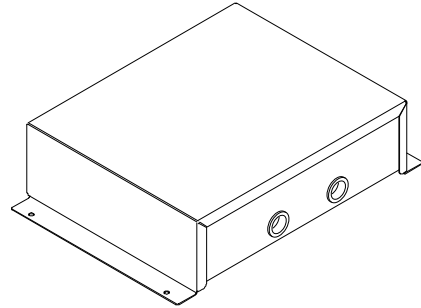

Network convertor is necessary if group remote controller is used.

■ EXTERNAL SWITCH CONTROLLER

- UTR-YESA



7-5. OTHERS

■ FLANGE (square)

Model : UTD-SF045T

■ For duct type

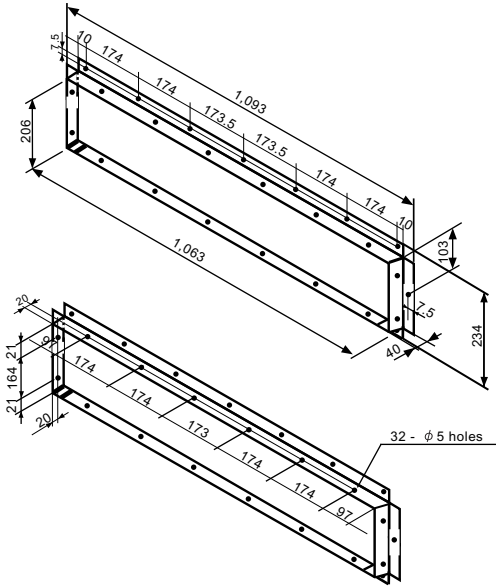

■ FLANGE (round)

Model : UTD-RF204

■ For duct type

(Unit : mm)

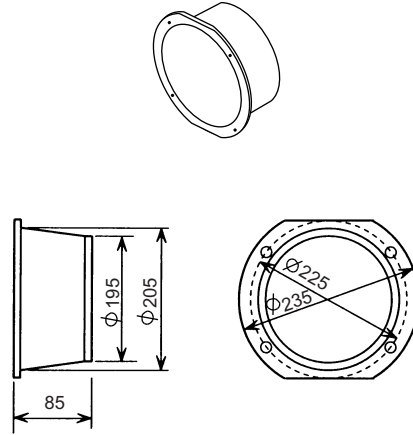

■ FLEXIBLE DUCT

Model : UTD-RD202

■ For duct type

ø200 mm L 2 m



■ LONG-LIFE FILTER

Model : UTD-LF270

■ For duct type

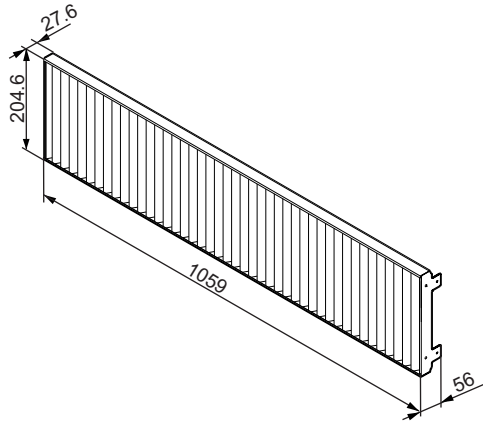

■ DRAIN PUMP UNIT

Model : UTZ-PX1BBA

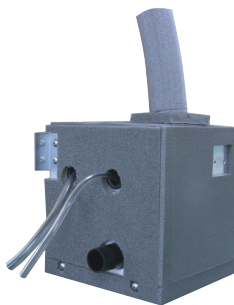

■ REMOTE SENSOR UNIT

Model : UTD-RS100

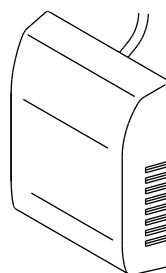

■ GRILLE KIT

Model : UTG-UDYD-W
UTG-UDGD-W
For compact cassette type

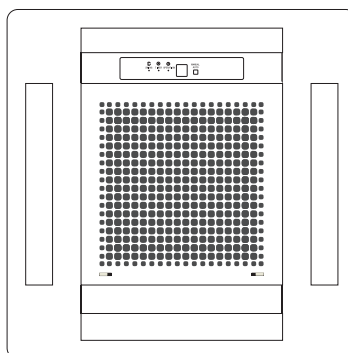



FUJITSU GENERAL LIMITED

1116, Suenaga, Takatsu-ku, Kawasaki 213-8502, Japan

Product specifications are subject to change without notice.

"**AIRSTAGE™**" is a worldwide trademark of FUJITSU GENERAL LIMITED.

Copyright © 2002 Fujitsu General Limited. All rights reserved.